

980710

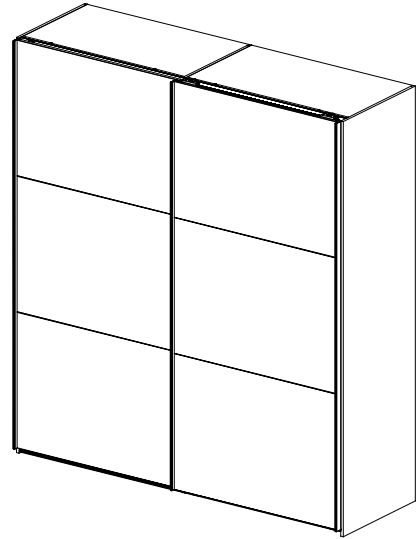

HSP SWT 200

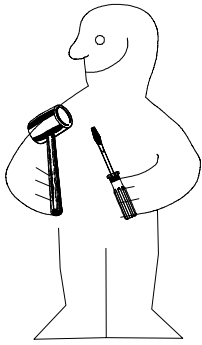
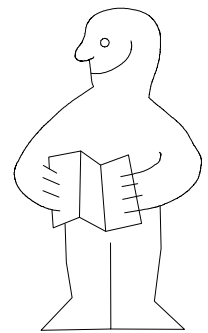
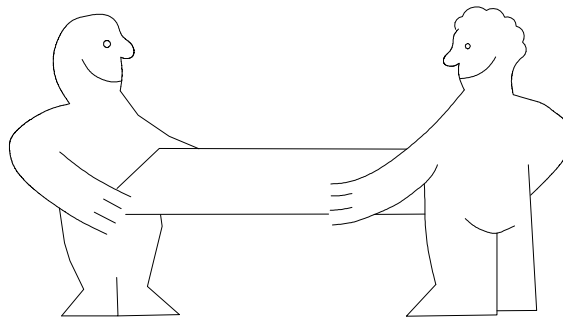
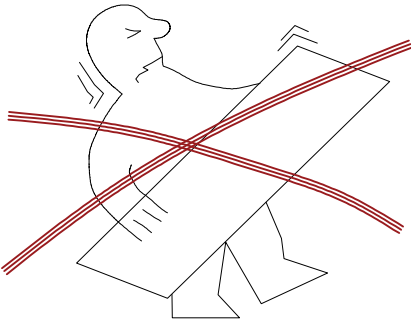

1-2-3-4... ○ ○

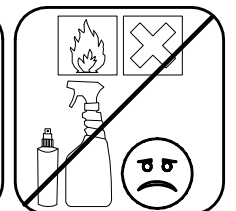
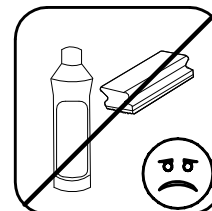
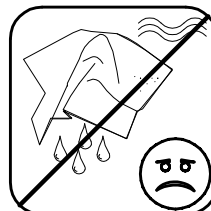
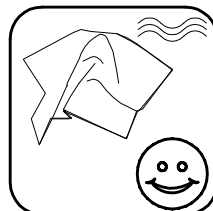
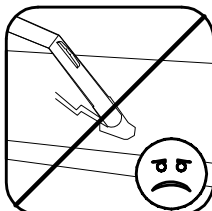
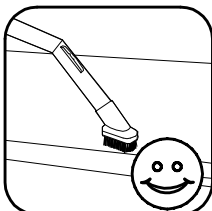
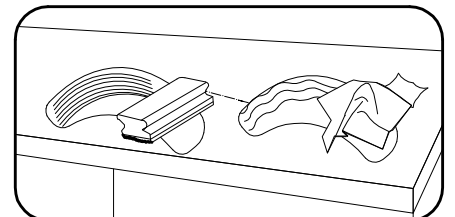
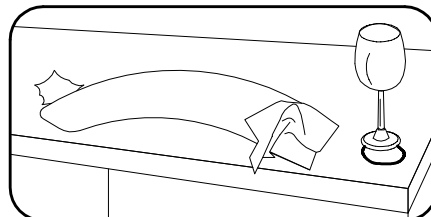
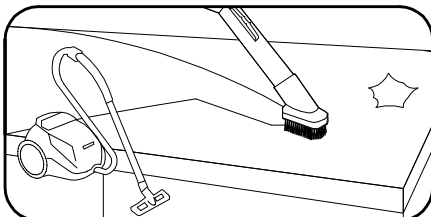
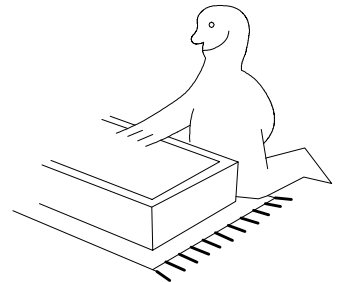
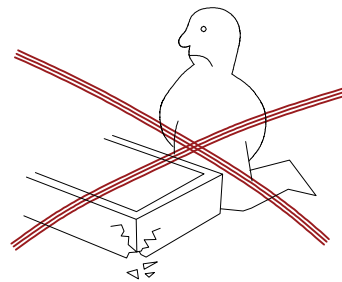
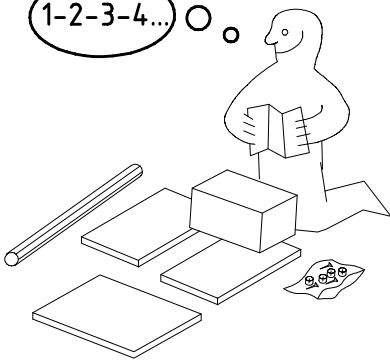

980710

17.09.25 /

09 25 | 01/36

LTU - LIETUVIŲ ĮSPĖJIMAS - SAUGOS PASTABA

Netinkamai sumontuoti arba ne pagal paskirtį naudojami baldai gali kelti pavojų gyvybei. Norint išvengti šio pavojaus ir sumažinti susižalojimo riziką, būtina laikytis toliau pateiktų saugos nurodymų:

- Baldus turi surinkti kvalifikuoti darbuotojai pagal surinkimo instrukcijas. Negalima per daug priveržti varžtų. Surinkimo metu vaikai turi būti atokiai.
- Visos pakuočės turi būti atidarytos ir perskaitytos visos surinkimo instrukcijos bei saugos nurodymai. Šie dokumentai turi būti laikomi saugioje vietoje. Montuojant galima naudoti tik originalias dalis.
- Baldai su pridėtamais sieniniais tvirtinimo elementais turi būti pritvirtinti prie sienos. Būtina laikytis pridėdamų saugos instrukcijų dėl tvirtinimo prie sienos.
- Baldai kelia pavojų vaikams: todėl pasipūpinkite, kad vaikai neliptų į stalčius ar kitas jų dalis, nesikeltų į juos ir nesikabinėtų ant jų.
- Baldai tinka toliau nurodytoms didžiausioms apkrovoms: lovos (vienam čiužiniui): 100 kg, komoda: 110 kg, nakminių stalikų ir komodų stalviršiai: 15 kg, stiklinės lentynos: 1 kg, sieninės plokštės: (priklausomai nuo tipo), stalčiai: 5 kg, įmontuotos lentynos: 10 kg, drabužių bėgeliai: 40 kg, sieninės spintelės: 20 kg, drabužių keltuvas: 10 kg, lovos stalčiai: 10 kg.

MLT - MALTI TWISSIJA - AVVIŻ TAS-SIGURTA

Għamara li mhix immuntata sew jew uzata għall-iskop mhabsud tagħha tista 'tkun ta' theddida għall-ħajja. Għalhekk, l-istruzzjonijiet tas-sigurtà li ġejjin għandhom jiġu osservati:

- L-għamara għandha tkun immuntata minn personal kwalifikat bl-użu tal-istruzzjonijiet tal-assemblaġġ. Il-viti mgħandhomx jiġu ssikkati żżejjed. Il-ftal għandhom jinżamm u l-bogħod waqt l-assemblaġġ.
- Il-pakketti kollha għandhom jinfetħu u l-istruzzjonijiet kollha tal-assemblaġġ u l-istruzzjonijiet tas-sigurtà jinqaw. Dawn id-dokumenti għandhom jinżamm. Partijiet originali biss huma permessi għall-assemblaġġ.
- Għamara b'immuntar fuq il-ħajt inkluz għandha titwaħħal mal-ħajt. L-istruzzjonijiet tas-sigurtà magħluqa għall-immuntar mal-ħajt għandhom jiġu osservati.
- L-għamara tohloq perikli għat-ftal: Jekk jogħġbok kun żgur li t-ftal ma jiġlghux fil-kaxxen jew partijiet oħra, jiġbdu lilhom infushom jew jiddendlu magħhom.
- L-għamara hija adattata għat-tagħbijiet massimi li ġejjin: Sodod (għal kull topper tas-saqqu): 100 kg, sedili tal-dresser: 110 kg, komodini u aċċessorji tal-dresser: 15 kg, xkafef tal-ħġieġ: 1 kg, pannelli tal-ħajt: skont it-tip, kaxxen: 5 kg, xkafef inkorporati: 10 kg, linjal tal-ħwejjeg: 40 kg, għamara tal-ħajt: 20 kg, lift tal-ħwejjeg: 10 kg, kaxxen tas-sodda: 10 kg.

ROU - ROMÂN AVERTIZARE - NOTĂ DE SIGURANȚĂ

Mobilier care nu este asamblat corect sau care nu este utilizat conform destinației poate pune viața în pericol. Prin urmare, trebuie respectate următoarele instrucțiuni de siguranță:

- Mobilierul este asamblat de personal calificat folosind instrucțiunile de asamblare. Șuruburile nu trebuie strânse prea tare. Copiii trebuie ținți departe în timpul asamblării.
- Toate ambalajele trebuie deschise și trebuie citite toate instrucțiunile de asamblare și instrucțiunile de siguranță. Aceste documente trebuie păstrate într-un loc sigur. Pentru asamblare pot fi utilizate numai piesele originale.
- Mobilierul cu elemente de fixare pe perete include trebuie să fie fixat pe perete. Trebuie respectate instrucțiunile de siguranță anexate pentru montarea pe perete.
- Mobilierul ascunde pericole pentru copii: prin urmare, asigurați-vă că copiii nu se urcă în sertare sau pe alte părți, nu se trag în sus sau nu se așază de ele.
- Mobilierul este adecvat pentru următoarele sarcini maxime: Paturi (per topper saltea): 100 kg; 100 kg; comodă: 110 kg; blaturi pentru noptieră și comodă: 15 kg; rafturi din sticlă: 1 kg, panouri de perete: în funcție de tip, sertare: 5 kg, rafturi încorporate: 10 kg, bare pentru haine: 40 kg, unități de perete: 20 kg, ridicător de haine: 10 kg, sertare de pat: 10 kg.

SWE - SVENSKA VARNING - SÄKERHETSMEDELANDE

Möbler som inte är korrekt monterade eller som inte används på avsett sätt kan vara livsfariga. För att undvika denna fara och minska risken för skador är det viktigt att följa följande säkerhetsanvisningar:

- Möblerna måste monteras av kvalificerad personal enligt monteringsanvisningarna. Skruvarna får inte dras åt för hårt. Barn ska hållas borta under monteringen.
- Alla förpackningar måste öppnas och alla monteringsanvisningar och säkerhetsanvisningar måste läsas. Dessa dokument måste förvaras på ett säkert ställe. Endast originaldelar får användas vid monteringen.
- Möbler med medföljande väggfästen måste fästas i väggen. Beakta bilogade säkerhetsanvisningar för väggmontering.
- Möbler innebär faror för barn: Se därför till att barn inte klättrar in i lådor eller på andra delar och inte heller drar sig upp eller hänger i dem.
- Möblerna är lämpliga för följande maximala belastningar: Sängar (per bäddmadrass): 100 kg, byrå: 110 kg, nattsduksbord och byråskivor: 15 kg, glashyllor: 1 kg, väggpaneler: beroende på typ, lådor: 5 kg, inbyggda hyllor: 10 kg, klädstänger: 40 kg, väggskåp: 20 kg, klädlyft: 10 kg, sänglådor: 10 kg.

GRC - ελληνικά ΠΡΟΕΙΔΟΠΟΙΗΣΗ - ΟΔΗΓΙΕΣ ΑΣΦΑΛΕΙΑΣ

Τα έπιπλα που δεν έχουν συναρμολογηθεί σωστά ή δεν χρησιμοποιούνται όπως προβλέπεται μπορεί να είναι απειλητικά για τη ζωή. Επομένως, πρέπει να τηρούνται οι ακόλουθες οδηγίες ασφαλείας:

- Τα έπιπλα πρέπει να συναρμολογούνται από εξειδικευμένο προσωπικό σύμφωνα με τις οδηγίες συναρμολόγησης. Οι βίδες δεν πρέπει να σφίγγονται υπερβολικά. Τα παιδιά πρέπει να μένουν μακριά κατά τη συναρμολόγηση.
- Όλες οι συσκευασίες πρέπει να είναι ανοιχτές και όλες οι οδηγίες συναρμολόγησης και οι οδηγίες ασφαλείας πρέπει να διαβάζονται και να φυλάσσονται σε ασφαλές μέρος. Για τη συναρμολόγηση επιτρέπεται να χρησιμοποιούνται μόνο γνήσια εξαρτήματα.
- Τα έπιπλα με κλειστά επιτοιχία εξαρτήματα πρέπει να στερεώνονται στον τοίχο. Πρέπει να τηρούνται οι συνημμένες οδηγίες ασφαλείας για την τοποθέτηση στον τοίχο.
- Τα έπιπλα κρβθουν κινδύνους για τα παιδιά: Για το λόγο αυτό, βεβαιωθείτε ότι τα παιδιά δεν σκαρφάλωνουν στα συρτάρια ή σε άλλα μέρη ή δεν τραβιούνται ή κρέμονται από αυτά.
- Τα έπιπλα είναι κατάλληλα για τα ακόλουθα μέγιστα φορτία: Κρεβάτια (ανά επικάλυψη στρώματος): συρτάρια: 110 kg, κομοδίνα και συρτάρια: 15 kg, γυάλινα ράφια: 1 kg, επιτοίχια πάνελ: ανάλογα με τον τύπο, συρτάρια: 5 kg, ενσωματωμένα ράφια: 10 kg, ράγες ρούχων: 40 kg, επιτοίχια έπιπλα: 20 kg, συμψυκτικό ρούχων: 10 kg, συρτάρια κρεβατιού: 10 kg.

IRL - GAELIGE RABHADH - FÓGRA SÁBHÁILTEACHTA

Is féidir le troscán nach gcuítear le chéile i gceart nó nach n-úsáidítear chun na críche atá beartaíte dhó a bheith bagrach don bheatha. Dá bhrí sin, ní mór cloi leis na treoracha sábháilteachta seo a leanas:

- Ní mór do phearsana cáiliúna an troscán a chur le chéile ag baint úsáide as na treoracha tionóil. Níor cheart scríúna a róthéamh. Ní mór leaná a choinneáil ar shiúl le linn tionóil.
- Ní mór gach pacáiste a oscailt agus gach treoir tionóil agus treoracha sábháilteachta a léamh. Ní mór na doiciméid seo a choinneáil. Ní cheadaítear ach páirteanna bunaidh a chur le chéile.
- Ní mór troscán le gléasadh balla san áireamh a cheangal leis an mballa. Ní mór cloi leis na treoracha sábháilteachta iniata le haghaidh gléasta balla.
- Tá contúirtí ag baint le troscán do leaná: Cinntigh le do thoil nach dtógfaidh leaná isteach i drawers nó páirteanna eile, go dtarraingíonn siad suas iad féin nó nach gcloifidh siad leo.
- Tá an troscán oiriúnach do na huaili uasta seo a leanas: Leapa (in aghaidh an topper tocht): 100 kg, suiocháin gúna: 110 kg, táblaí ciad leapa agus ceangaltán gúna: 15 kg, seilfeanna gloine: 1 kg, painéil balla: ag brath ar an gceinéal, tarraiceán: 5 kg, Seilfeanna insuite: 10 kg, ráilí éadaí: 40 kg, troscán balla: 20 kg, ardaitheoir éadaí: 10 kg, tarraiceán leaba: 10kg.

HRV - Hrvatski UPOZORENJE - SIGURNOSNA OBAVIJEST

Namještaj koji nije pravilno sastavljen ili korišten prema namjeni može biti opasan po život. Kako biste izbjegli ovu opasnost i smanjili rizik od ozljeda, važno je pridržavati se sljedećih sigurnosnih uputa:

- Namještaj mora sastaviti kvalificirano osoblje prema uputama za sastavljanje. Vijci se ne smiju previše zategnuti. Az öszeszerezés során a gyerekeket távol kell tartani.
- Sva pakiranja moraju biti otvorena i pročitane sve upute za sastavljanje i sigurnosne upute. Ovi dokumenti moraju se čuvati. Za montažu su dopušteni samo originalni dijelovi.
- Namještaj s uključenom montažom na zid mora biti pričvršćen na zid. Morate se pridržavati priloženih sigurnosnih uputa za zidnu montažu.
- Namještaj predstavlja opasnost za djecu: Pazite da se djeca ne penju u ladice ili druge dijelove, da se ne povlače ili vise na njima.
- Namještaj je prikladan za sljedeća maksimalna opterećenja: Kreveti (po nadmadracu): 100 kg, sjedala za komode: 110 kg, noćni ormarići i dodaci za komode: 15 kg, staklene police: 1 kg, zidne ploče: ovisno o vrsti, ladice: 5 kg, ugradbene police: 10 kg, šipke za odjeću: 40 kg, zidni namještaj: 20 kg, podizač odjeće: 10 kg, ladice za krevet: 10 kg.

LVA - Latvīšu BRĪDINĀJUMS - DROŠĪBAS INSTRUKCIJAS

Mēbeles, kas nav pareizi samontētas vai netiek lietotas atbilstoši paredzētajam mērķim, var apdraudēt dzīvību. Lai izvairītos no šādām briesmām un samazinātu traumu risku, ir svarīgi ievērot turpmāk minētos drošības norādījumus:

- Mēbeles jāsamontē kvalificētam personālam saskaņā ar montāžas instrukcijām. Skrūves nedrīkst pārspīlēt. Montāžas laikā bērniem jābūt prom.
- Jaatver visi iepakojumi un jāizlasa visas montāžas instrukcijas un drošības norādījumi. Sie dokumenti jāglabā drošā vietā. Montāžai drīkst izmantot tikai oriģinālās detaļas.
- Mēbeles ar pievienotiem sienas tvirtinumiem jāpiesietur pie sienas. Jāievēro pievienotie drošības norādījumi par montāžu pie sienas.
- Mēbeles slēpj briesmas bērniem: tāpēc pārīecienieties, ka bērni nelien atvilktnēs vai uz citām mēbeļu daļām, nevelk uz tām vai karājas uz tām.
- Mēbeles ir piemērotas šādām maksimālajām slodzēm: Gultas (uz matrača pārvalka): 100 kg, kumodes: 110 kg, naktskapjišu un kumodes virsma: 15 kg, stikla plaukti: 1 kg, slenas paneļi: atkarībā no tipa, atvilktnes: 5 kg, iebūvētie plaukti: 10 kg, drēbju pakaramie: 40 kg, sienas skapīši: 20 kg, drēbju pacelājs: 10 kg, gultas atvilktnes: 10 kg.

BGR - Български ПРЕДУПРЕЖДЕНИЕ - ИНСТРУКЦИИ ЗА БЕЗОПАСНОСТ

Мебели, които не саглобени правилно или не се използват по предназначение, могат да бъдат опасни за живота. Следователно трябва да се спазват следните инструкции за безопасност:

- Мебелите трябва да се глобяват от квалифициран персонал в съответствие с инструкциите за глобяване. Винтовете не трябва да се затягат прекалено. Децата трябва да се държат настрана по време на монтажа.
- Всички опаковки трябва да бъдат отворени и всички инструкции за монтаж и безопасност трябва да бъдат прочетени и съхранявани безопасно. За глобяването могат да се използват само оригинални части.
- Мебелите с вградени стени приспособления трябва да бъдат закрепени към стената. Трябва да се спазват приложените инструкции за безопасност при монтаж на стена.
- Мебелите крият опасности за децата: Затова се уверете, че децата не се катерят по чекмеджетата или по други части, не се издърпват или не висят от тях.
- Мебелите са подходящи за следните максимални натоварвания: ягла (за един гол матрак): 100 кг, скрин: 110 кг, плотове за нощни шкафчета и скрин: 15 кг, стъклените рафтове: 1 кг, стенини панели: в зависимост от вида, чекмеджета: 5 кг, вградени рафтове: 10 кг, релси за дрехи: 40 кг, стенини шкафове: 20 кг, подемник за дрехи: 10 кг, чекмеджета за легла: 10 кг.

DNK - Dansk ADVARSEL - SIKKERHEDSINSTRUKTIONER

Møbler, der ikke er samlet korrekt eller ikke anvendes efter hensigten, kan være livsfarlige. For at undgå denne fare og reducere risikoen for skader skal følgende sikkerhedsanvisninger overholdes:

- Møblene skal samles af kvalificeret personale i overensstemmelse med monteringsvejledningen. Skruer må ikke overspændes. Børn skal holdes væk under montering.
- Alle pakker skal åbnes, og alle monteringsanvisninger og sikkerhedsanvisninger skal læses. Disse dokumenter skal opbevares på et sikkert sted. Der må kun bruges originale dele til monteringen.
- Møbler med vedlagte vægbeslag skal fastgøres til væggen. De vedlagte sikkerhedsanvisninger for vægmontering skal overholdes.
- Møbler nummer farer for børn: Sørg derfor for, at børn ikke kravler ind i skuffer eller på andre dele eller trækker sig op eller hænger i dem.
- Møblerne er egnede til følgende maksimale belastninger: Senge (pr. topmadræs): 100 kg, kommode: 110 kg, natbords- og kommodeplader: 15 kg, glashylder: 1 kg, vægpaneler: afhængigt af type, skuffer: 5 kg, indbyggede hylder: 10 kg, bøjlestænger: 40 kg, overskabe: 20 kg, tøjlift: 10 kg, sengeskuffer: 10 kg.

EST - Eesti HOIATUS - OHUTUSJUHISED

Korrektselt kokku panemata või mitte ettenähtud viisil kasutatav mööbel võib olla eluohtlik. Selle ohu vältimiseks ja vigastusohu vähendamiseks on oluline järgida järgmisi ohutusjuhiseid:

- Mööblit peavad monteerima kvalifitseeritud töötajad vastavalt monteerimisjuhendile. Krusivid ei tohi üle pingutada. Lapsed tuleb kokkupaneku ajal eemal hoida.
- Kõiki pakendit tuleb avada ning lugeda kõiki koostamisjuhiseid ja ohutusjuhiseid. Neid dokumente tuleb hoida turvalises kohas. Kokkupanekuks tohib kasutada ainult originaalosi.
- Kinnitatud seinakinnitustega mööbel tuleb kinnitada seinale külge. Tuleb järgida lisatud ohutusjuhiseid seinakinnituse kohta.
- Mööbel katkeab endas ohte lastele: seepärast veenduge, et lapsed ei ronil sahtlitesse või muudesse osadesse, ei tõmba end üles ega ripu nende külge.
- Mööbel sobib järgmiste maksimaalsete koormuste jaoks: Voodid (ühe madratsitopperi kohta): 100 kg, kapp: 110 kg, öökapid ja kapid laud: 15 kg, klaasriiulid: 1 kg, seinapaneelid: sõltuvalt tüübist, sahtlid: 5 kg, sisseehitatud riidid: 10 kg, riederiitid: 40 kg, seinapaneelid: 20 kg, riidelifti: 10 kg, voodisahtlid: 10 kg.

FIN - suomalainen VAROITUS - TURVALLISUUSOHJEET

Huonekalut, joita ei ole koottu oikein tai joita ei käytetä tarkoitellu tavalla, voivat olla hengenvaarallisia. Tämän vaaran välttämiseksi ja loukkaantumisriskin vähentämiseksi on noudatettava seuraavia turvallisuusohjeita:

- Pätevän henkilöstön on koottava kalusteet kokoonpano-ohjeiden mukaisesti. Ruuveja ei saa kiristää liikaa. Lapset on pidettävä loitolla kokoamisen aikana.
- Kaikki pakkaukset on avattava ja kaikki kokoonpano- ja turvallisuusohjeet on luettava. Nämä asiakirjat on säilytettävä turvallisessa paikassa. Kokoonpanossa saa käyttää vain alkuperäisiä osia.
- Huonekalut, joissa on mukana seinäkiinnikkeet, on kiinnitettävä seinään. Oheisia seinäkiinnitystä koskevia turvallisuusohjeita on noudatettava.
- Huonekaluihin liittyv vaarallisia lauseita: Varmista siksi että lapset eivät kineile laatikoihin tai muihin osiin eivätkä vedä itseään vöös tai miki niteä.

980710

17.09.25 /

09 25

03/36

 111 149	A1	16x
 111 103	C	8x
 3,5 x 15 mm	F3	4x
 121 370	G1	28x

 111 611	J2	6x
 117 002	K2	4x
 957mm 112 420	K100	2x

 111 607	L8	8x
 111 052	o10	1x
 111 143	SBV	16x
 111 300	S0	10x

 4 X 13mm 121 122	SP13	3x
 6,3x10,5 112 055	T1	20x
 111 xxx φ12	V12	10x

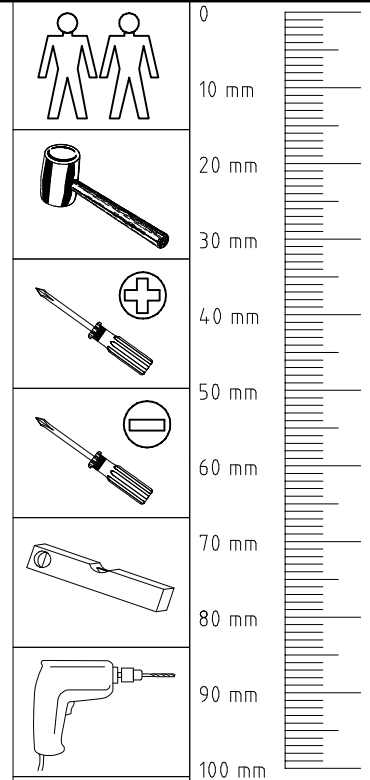

 121 370 3,5x35 mm	G1	10x
 121 375	G14	2x
 M4x10	G43	4x
 M4x13 PZ	GH13	4x
 114 183	H5	4x
 121 122	SP13	66x

 190014/015	SW-AK	3x
 190014/015	SW-AS	2x
 190014/015	SW-F1	4x
 190014/015	SW-F2	2x
 190014/015	SW-F3	2x
 L=1941m	SW-FP	1x

 L=1941	SW-LP	1x
 LA12117	SW-LA	1x
 LA12116	SW-LB	1x
 LA12135	SW-LC	1x
 LA12175	SW-LD	1x
 L=1941m	SW-M6x20	2x

 L=1941	SW-SKL	1x
 L=1941	SW-SKR	1x
 L=1941	SW-SKM	2x
 L=1941	SW-ST	2x
 111 030 6,3 x 11	T2	26x

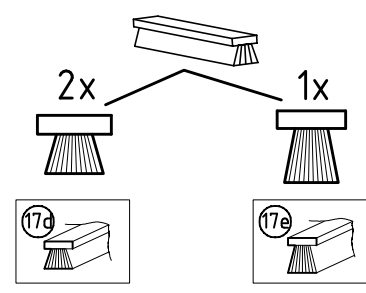
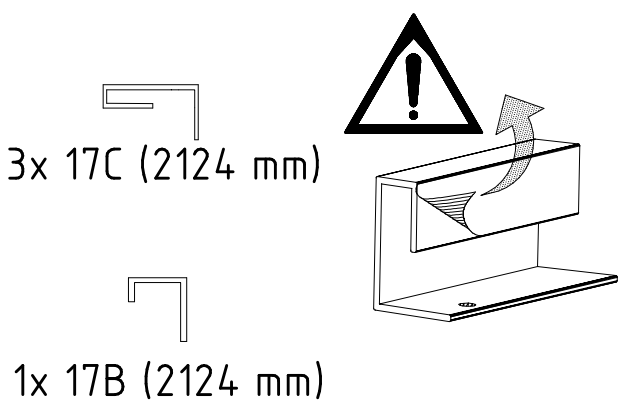
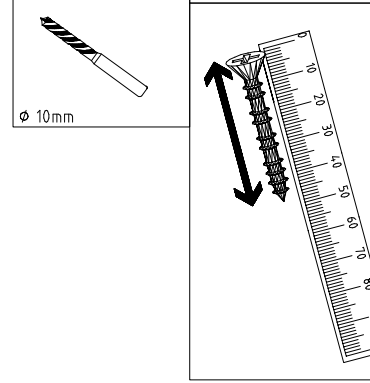

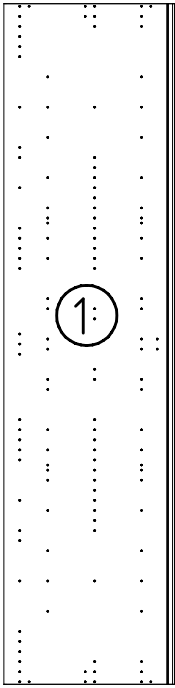
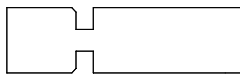
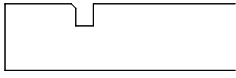

=

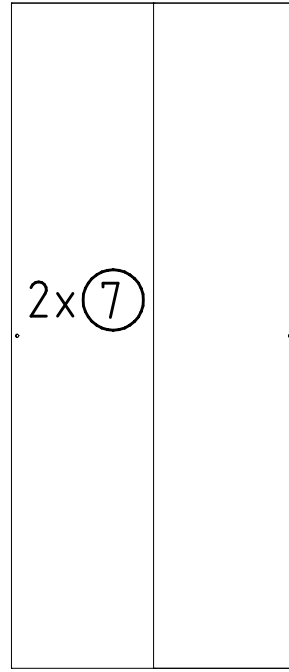
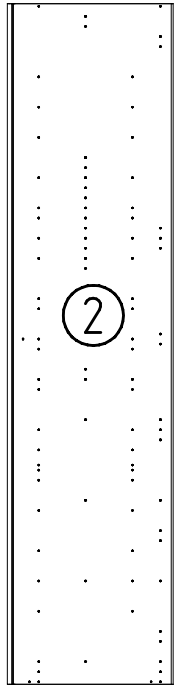
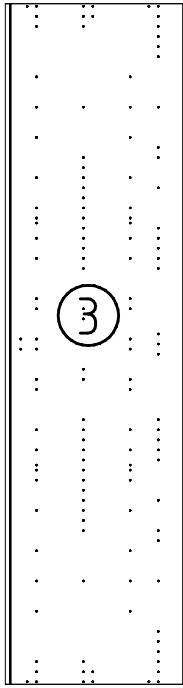

2160x577x15

2160x607x15

2160x560x15

2111x973x2,5

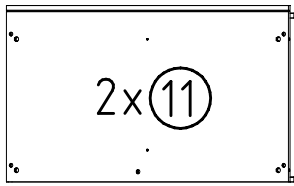

964x560x47

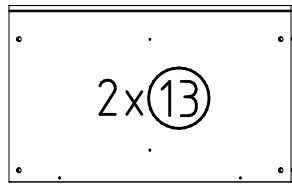

964x560x15

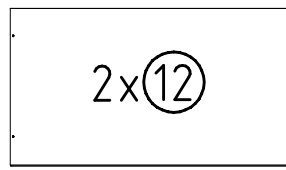

964x500x15

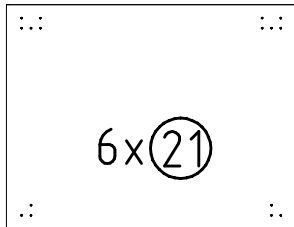

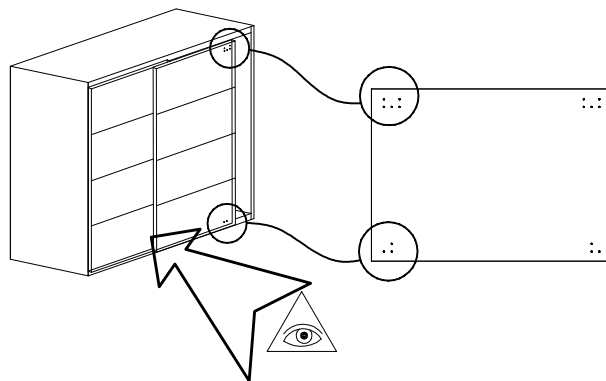

990x708x15

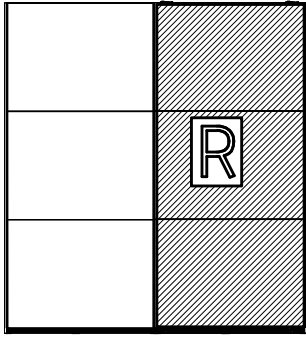

1

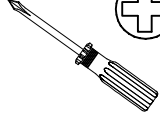

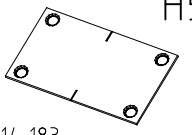
 121 122	 4 X 13mm SP13  114 183	 H5 114 183
--	--	---

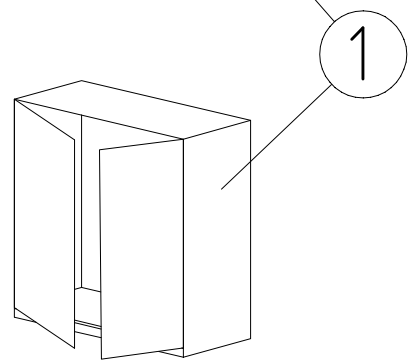
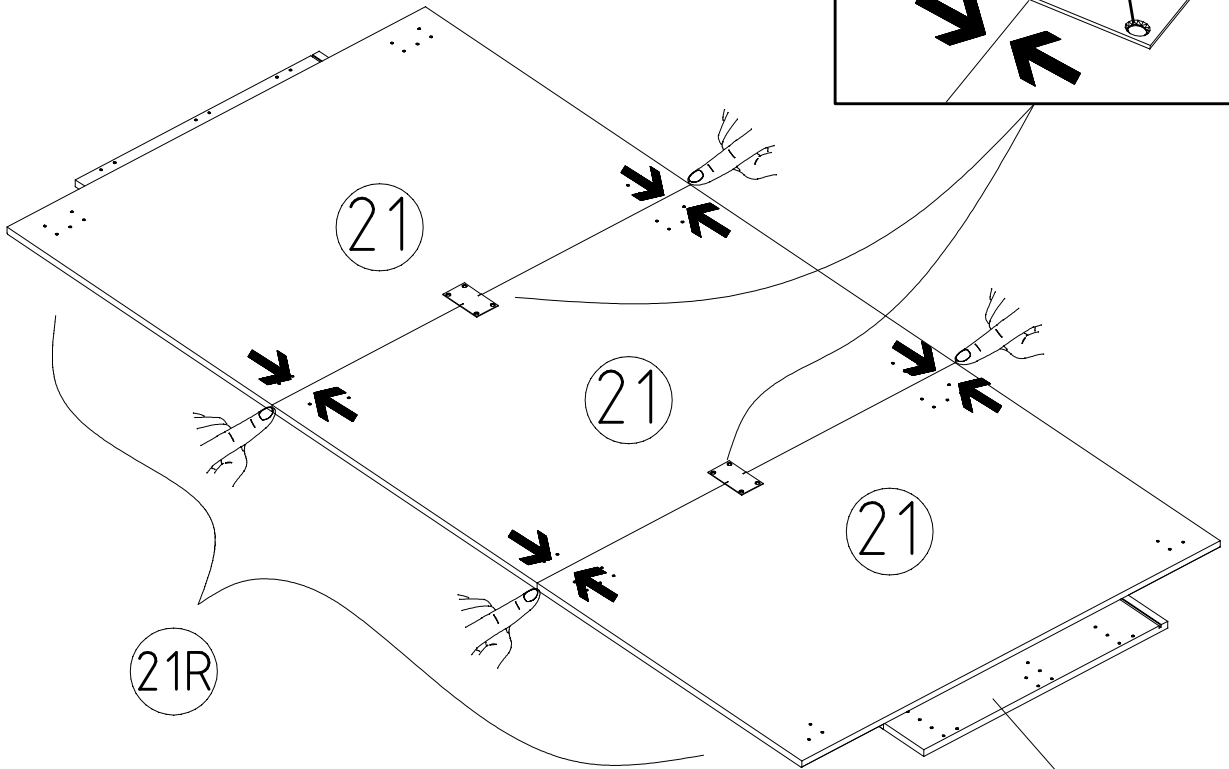
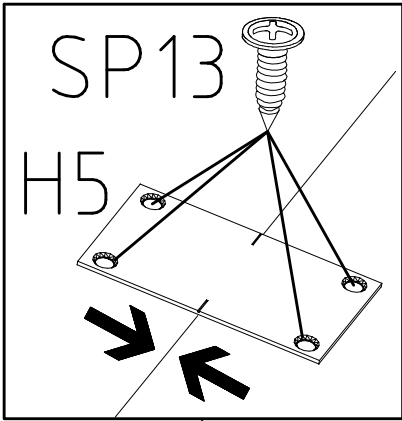

2

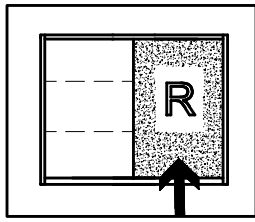

SP13
4 X 13mm
121 122

17c
2x

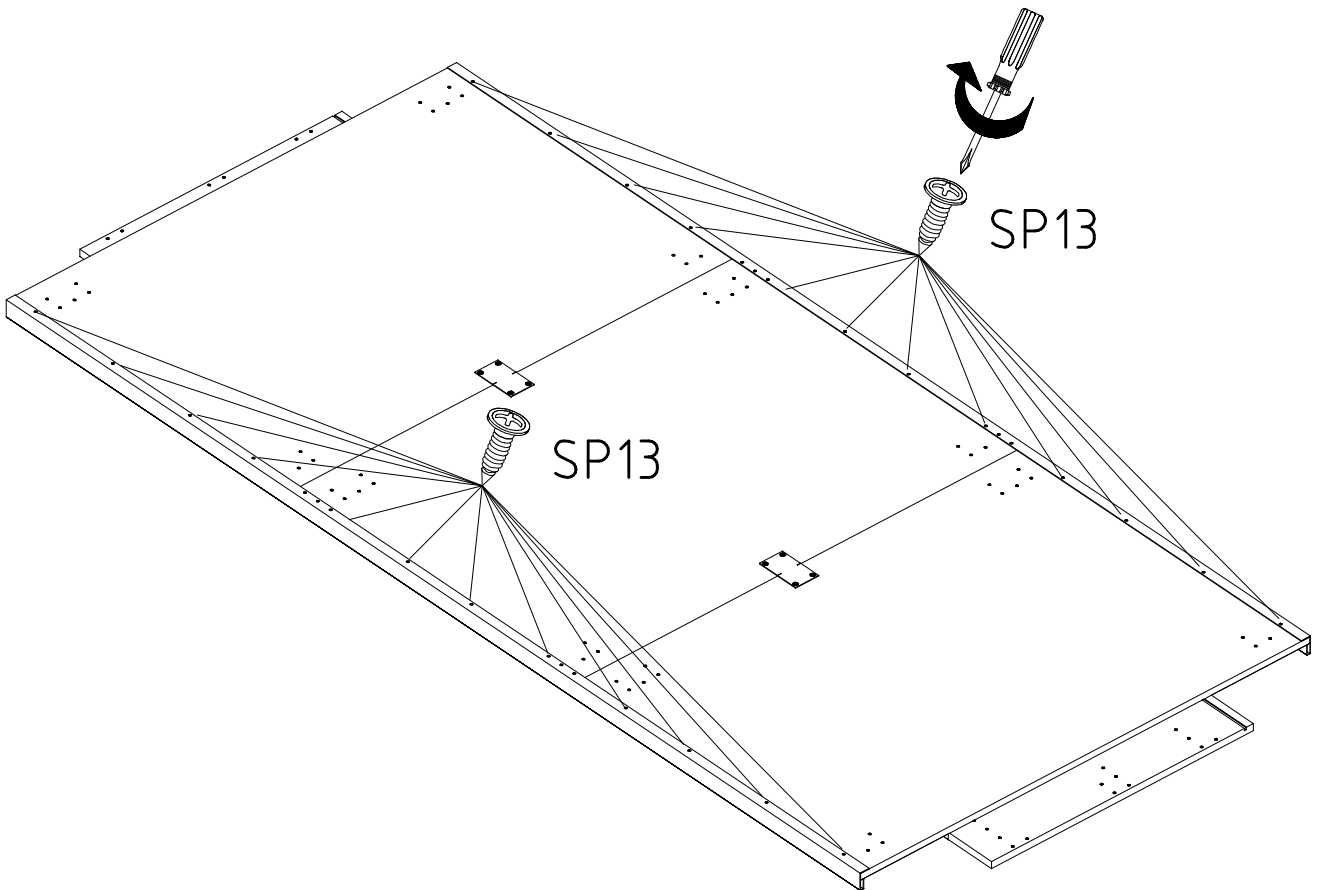
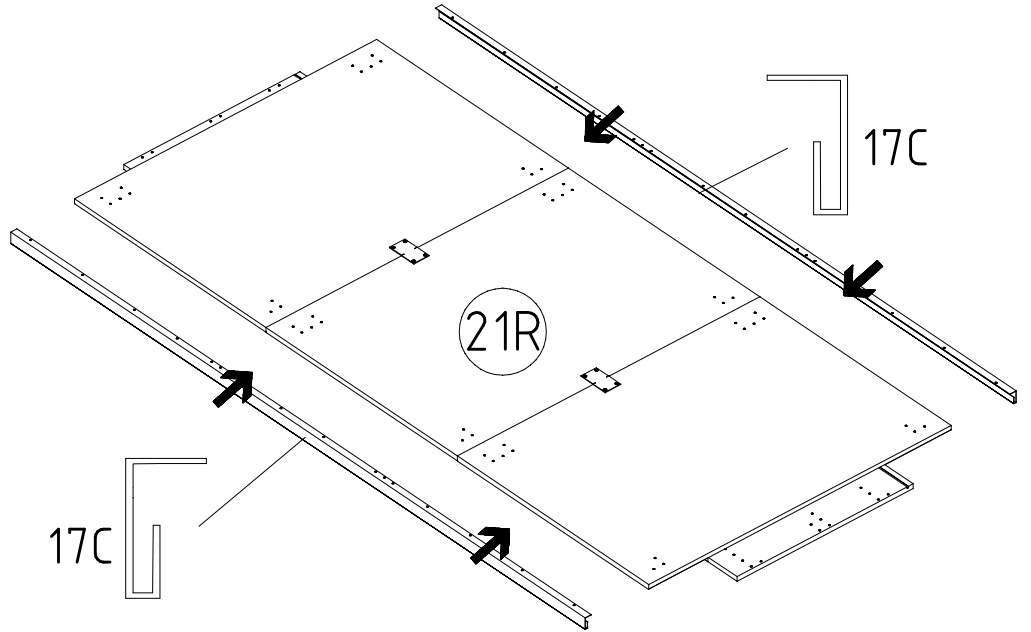
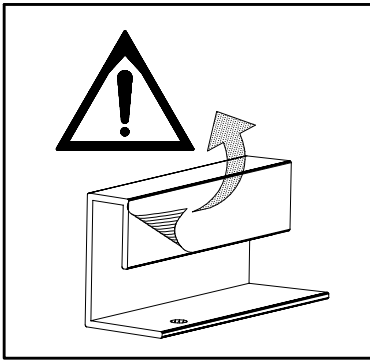

3

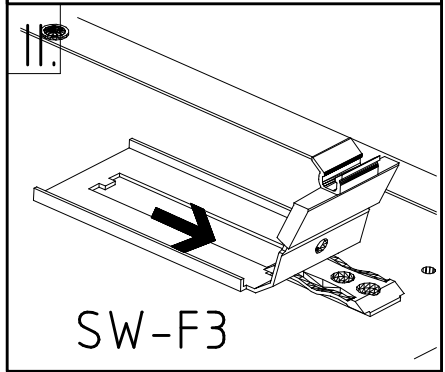
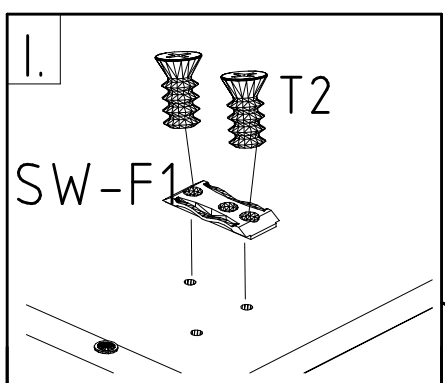
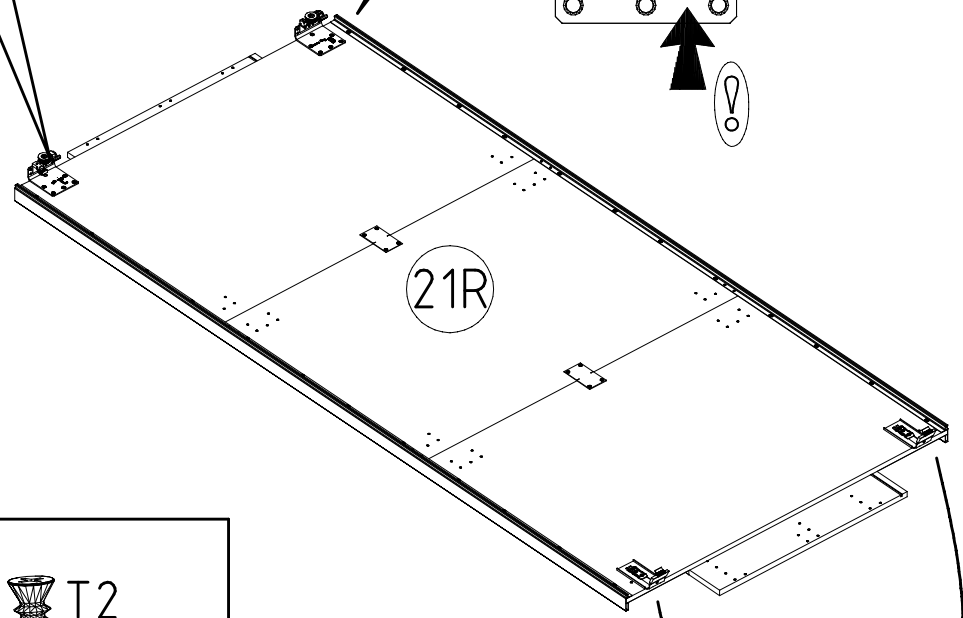
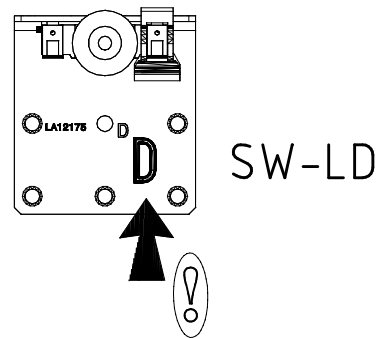
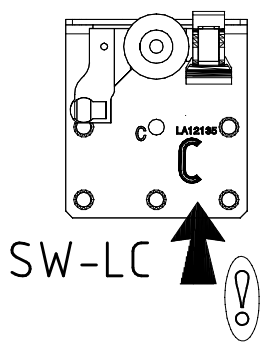
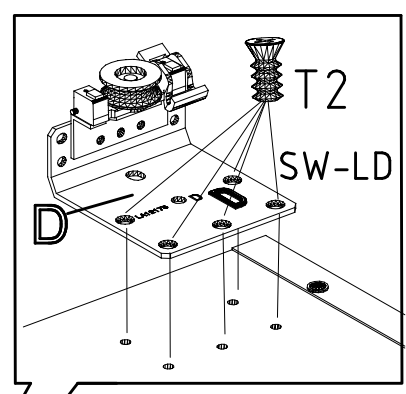
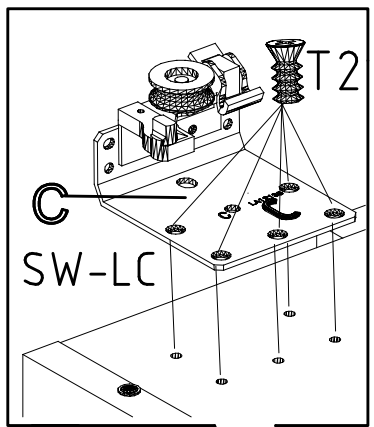
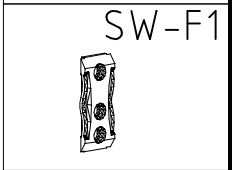
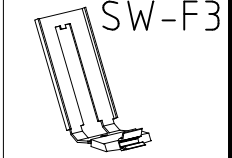
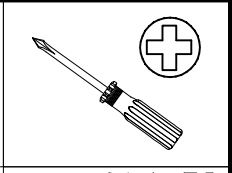
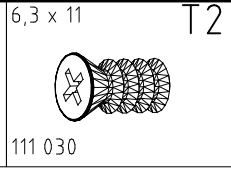
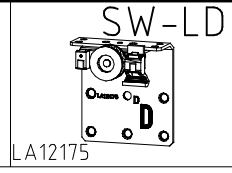
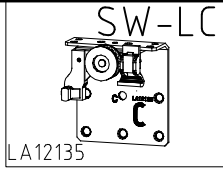
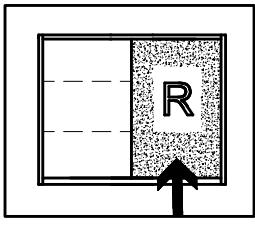

4

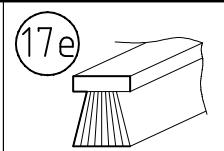
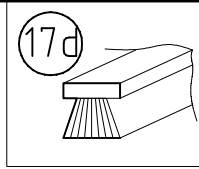
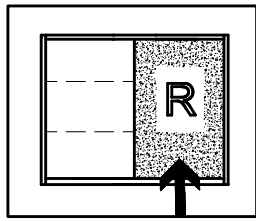

SW-AK



190014/015

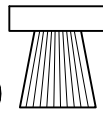
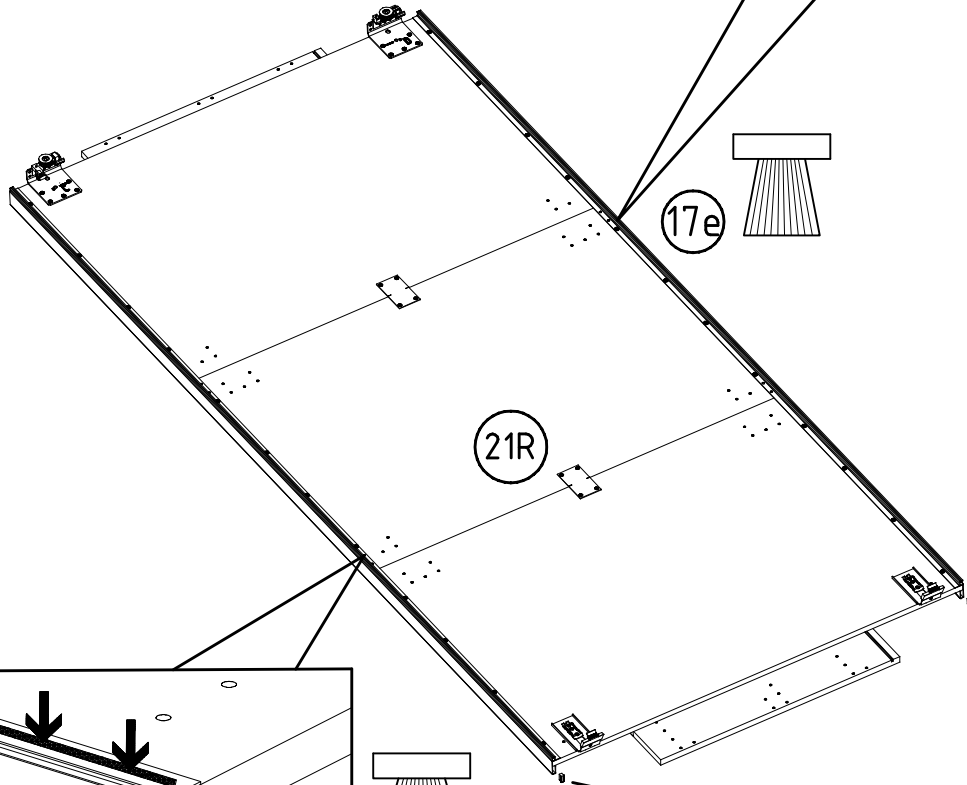
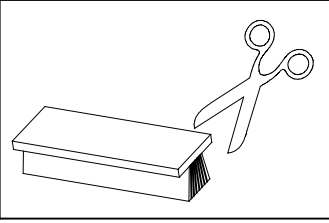
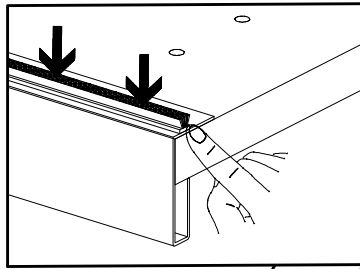
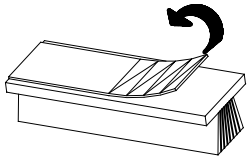

17e

21R

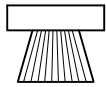
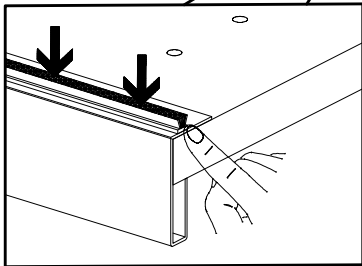

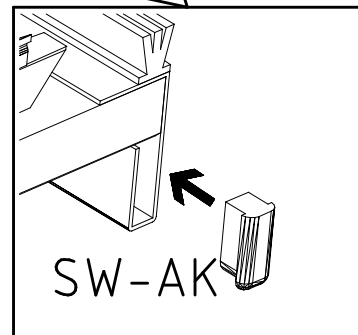
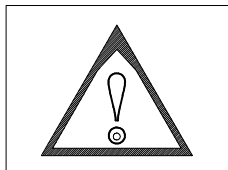

17d

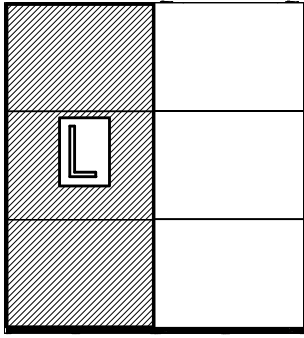

5

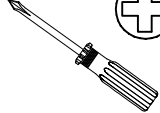

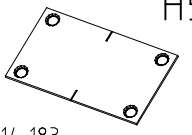
 121 122	 4 X 13mm SP13 121 122	 H5 114 183
--	---	---

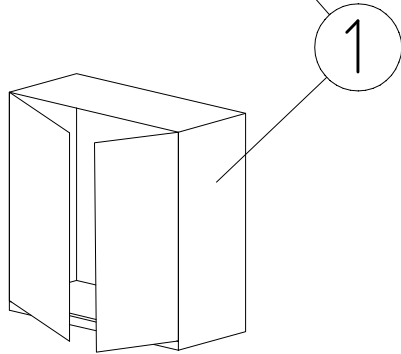
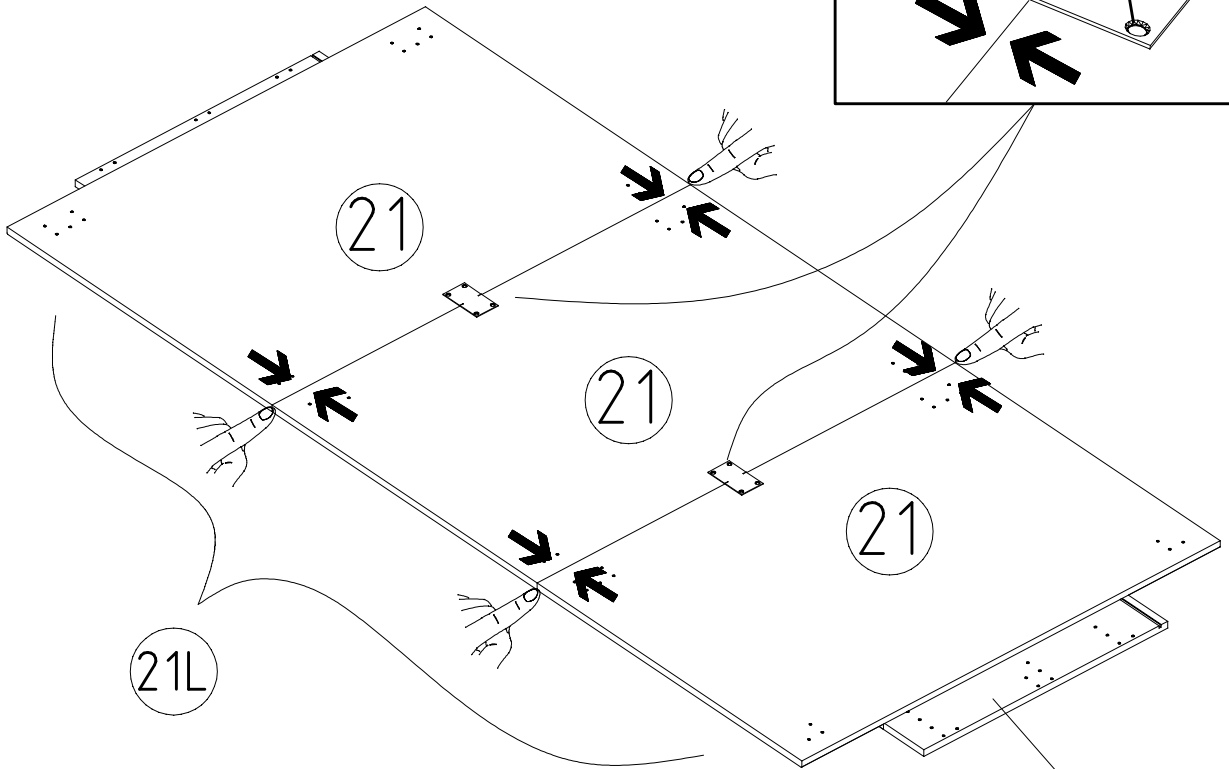
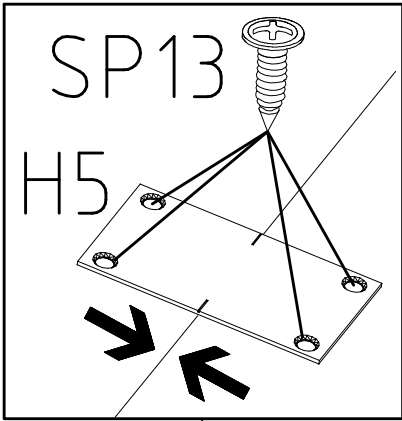

6

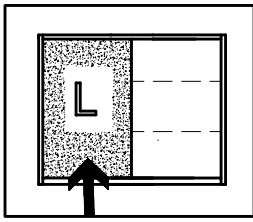

	SP13
	4 X 13mm
	121 122

	(17B)
	(17C)

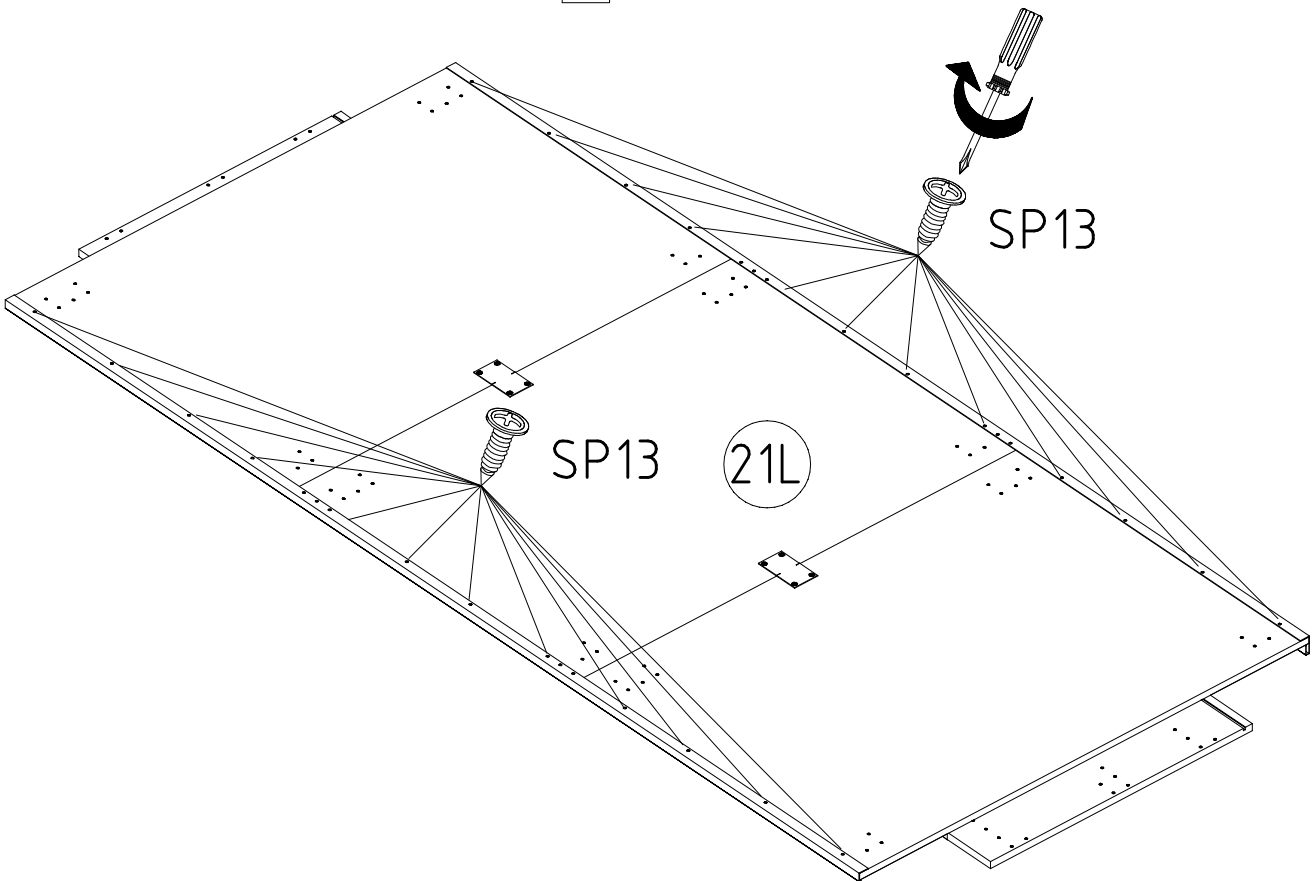
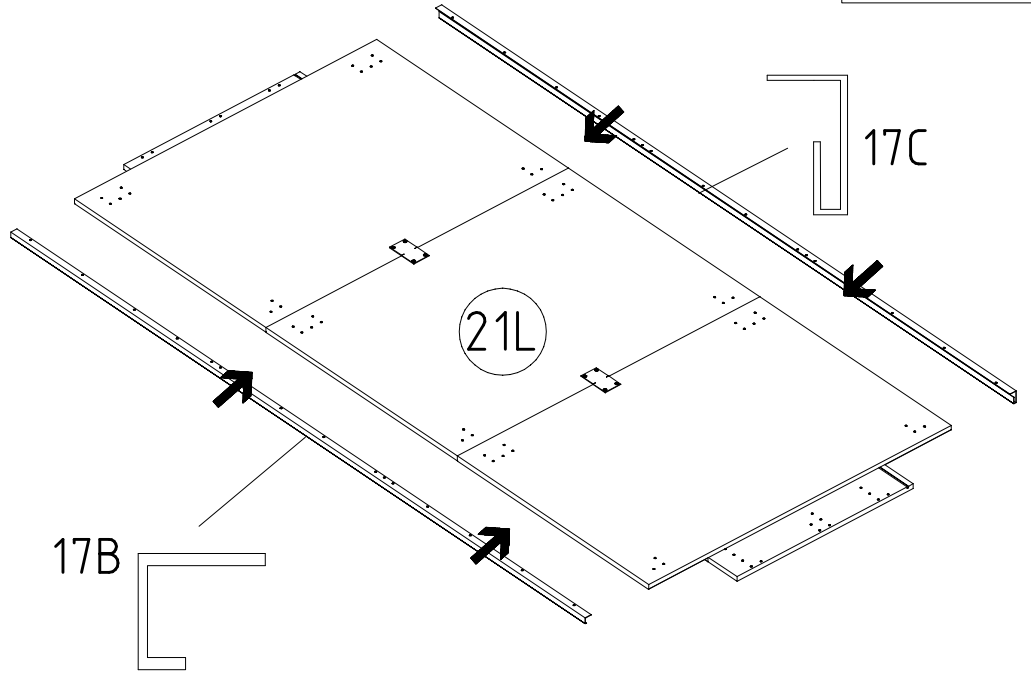
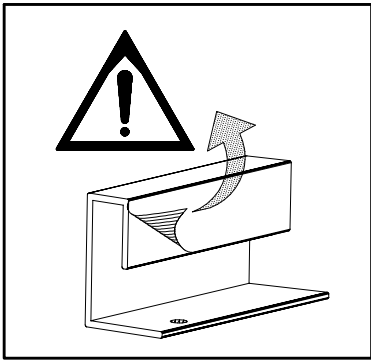

7

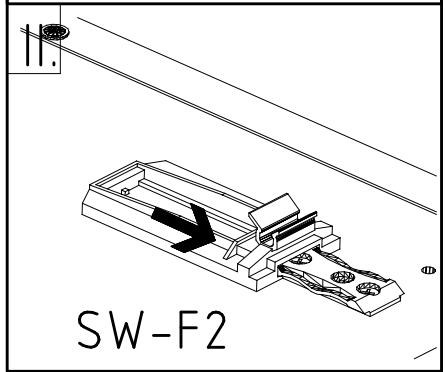
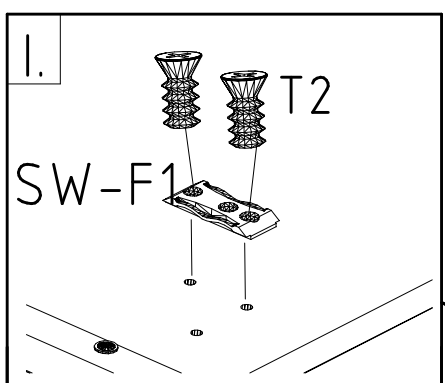
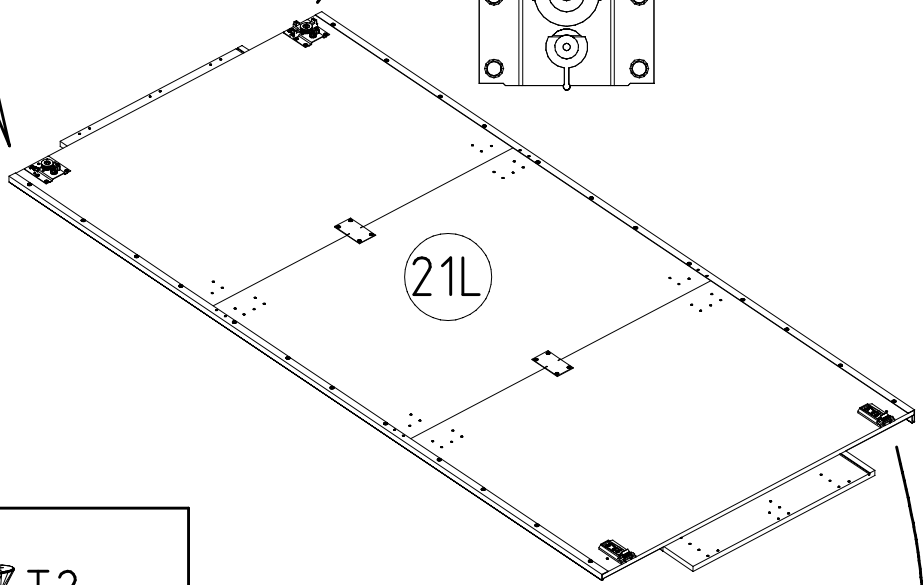
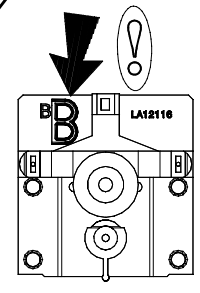
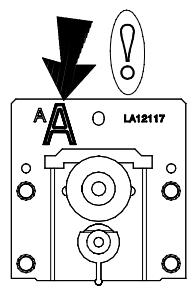
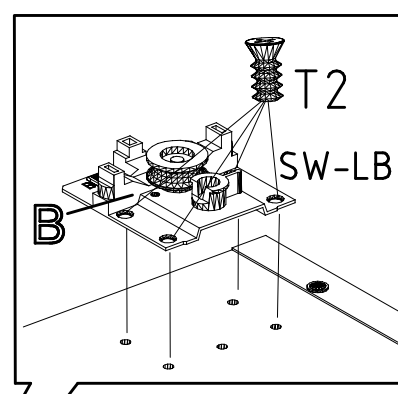
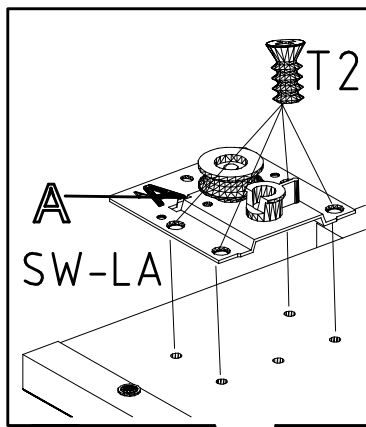
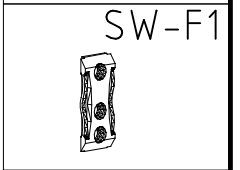
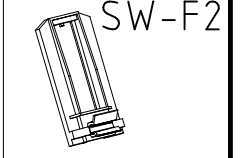
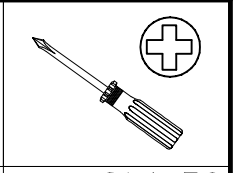
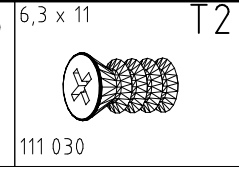
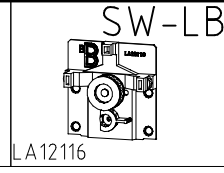
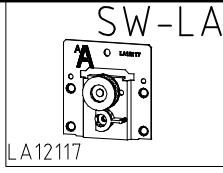
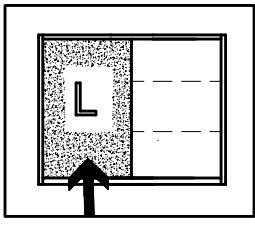

8

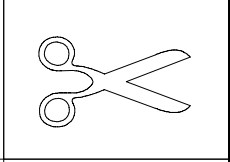
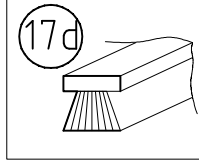
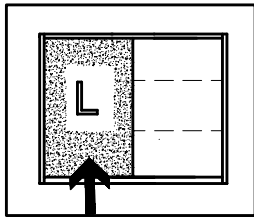

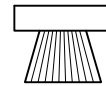
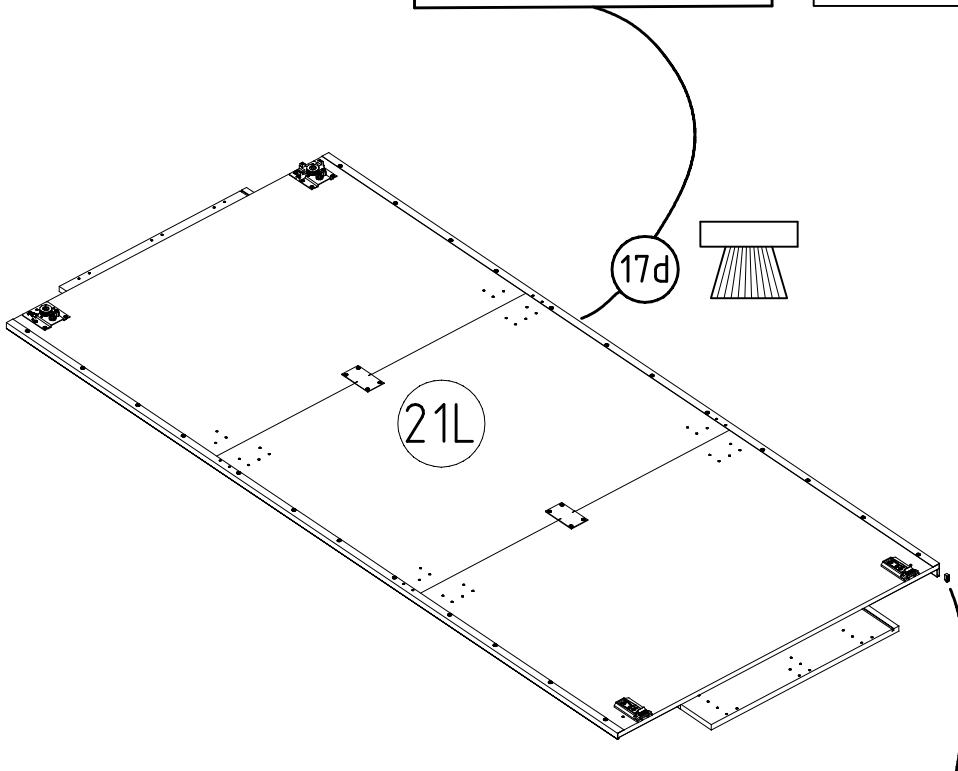
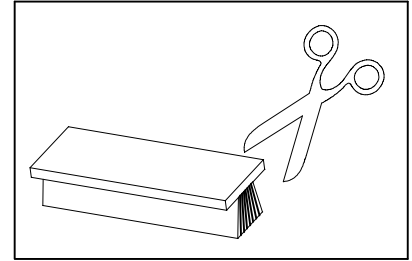
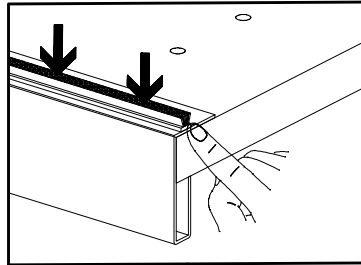
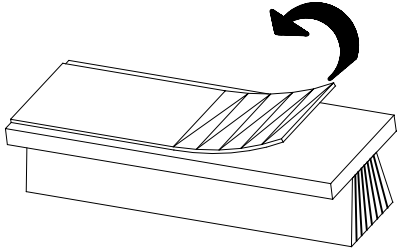

SW-AK
190014/015

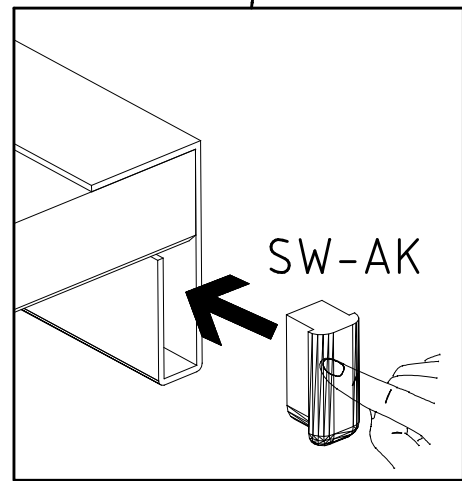
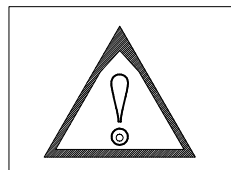

21L



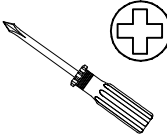

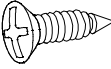
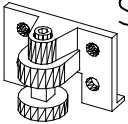
9

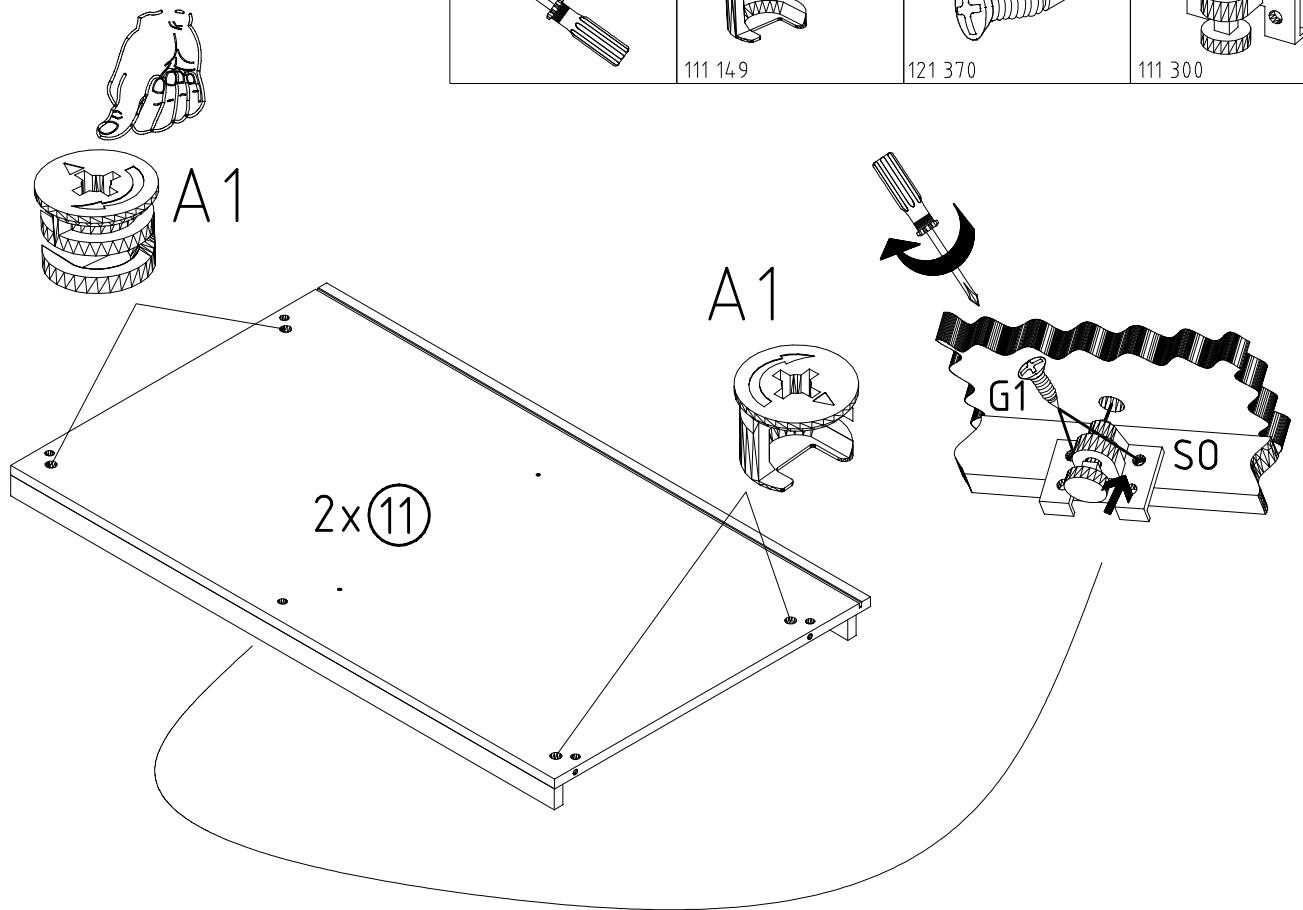
	 111 149	3,5 x 15 mm G1  121 370	 111 300
--	--	--	---

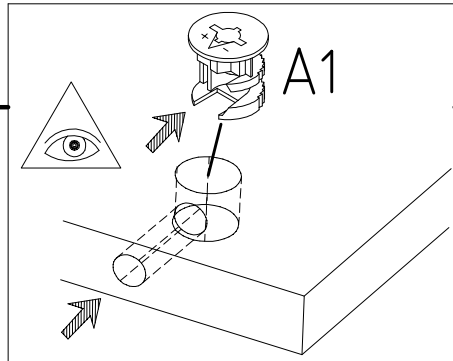

10



 111 149	A1
--	----

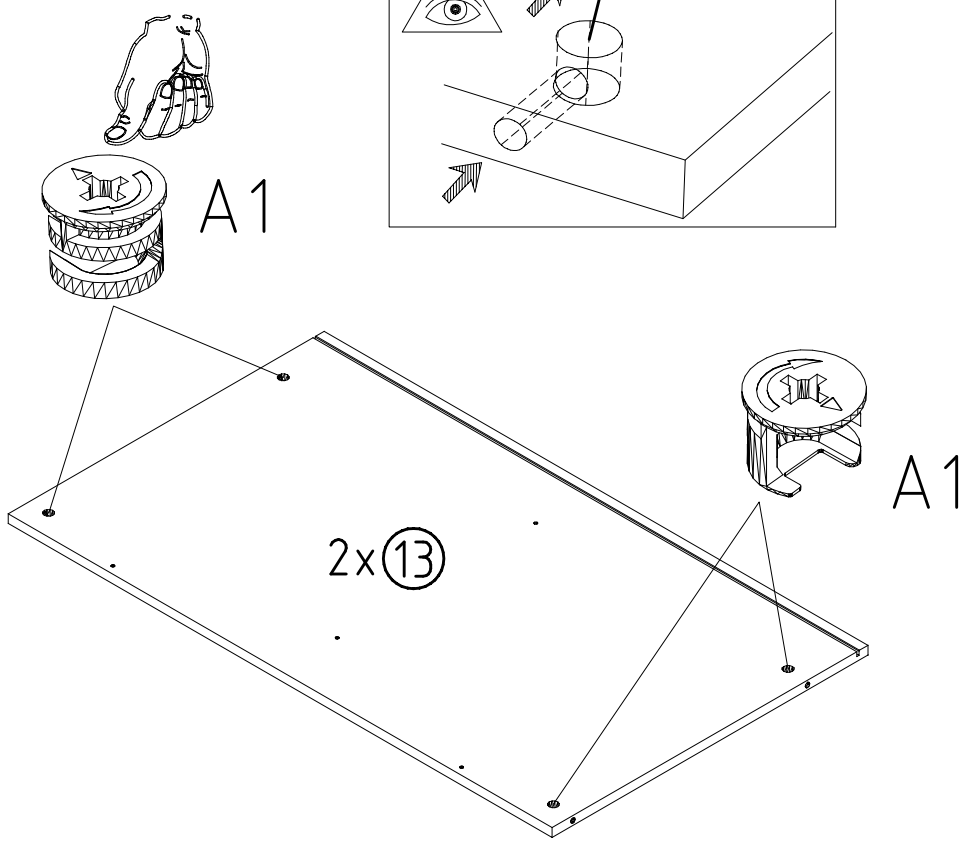

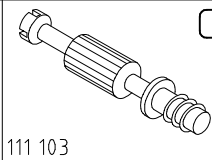

SW-SKL

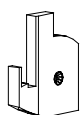

SW-SKR

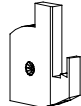

3,5 x 15 mm G1

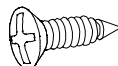

121 370

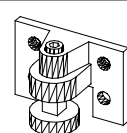

111 300



6,3x10,5



112 055

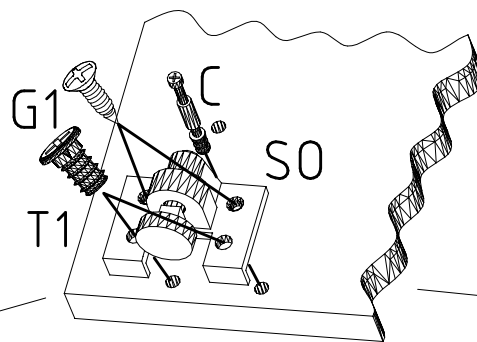
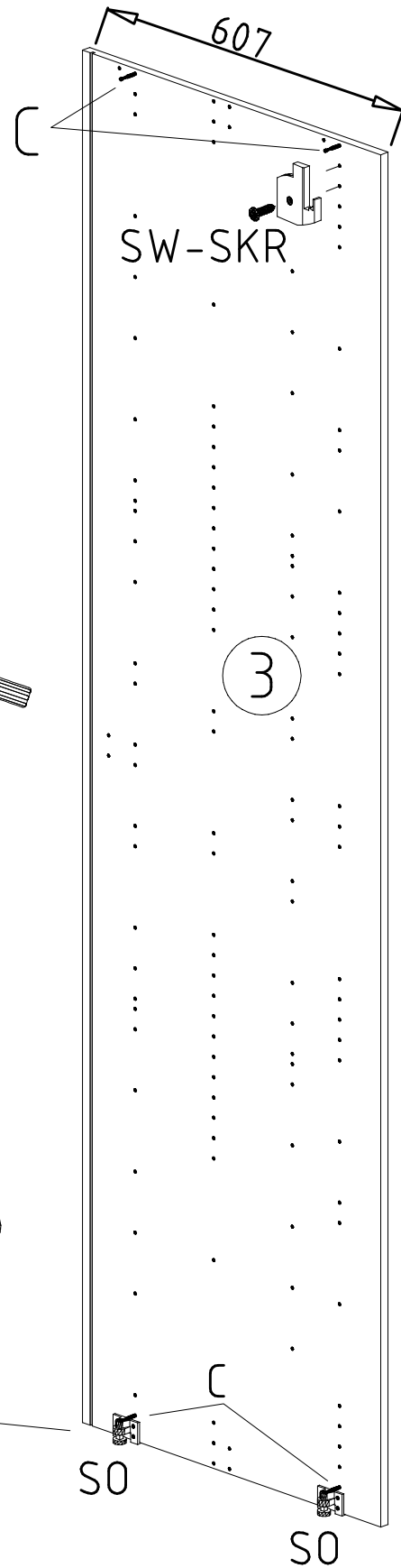
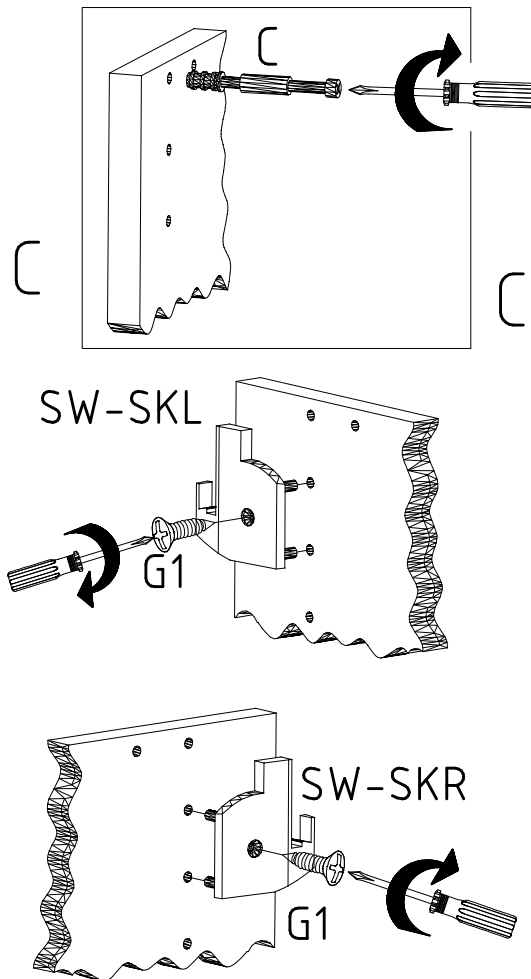
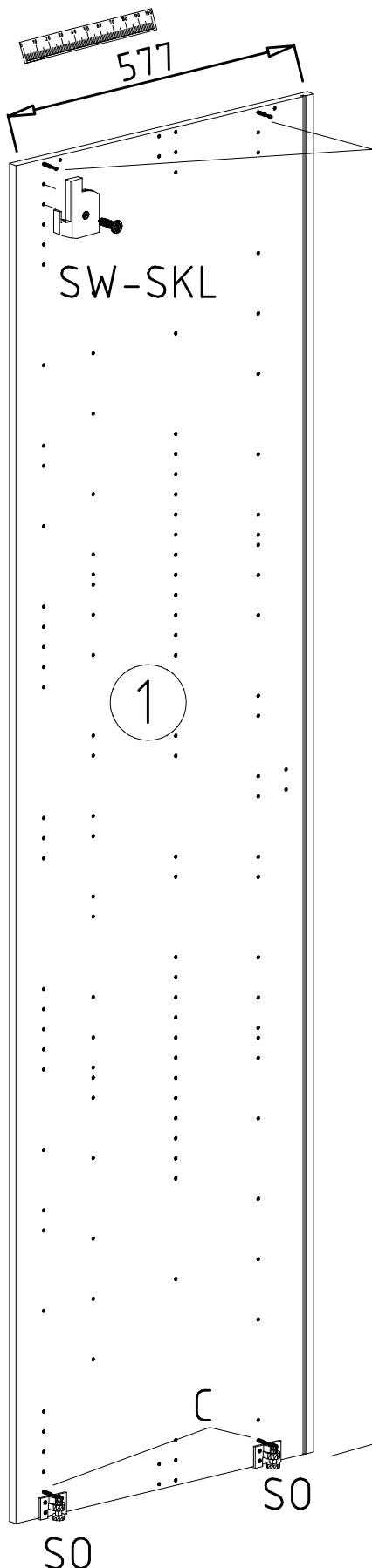
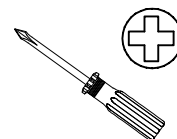

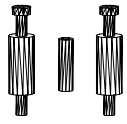
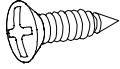
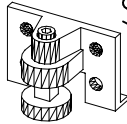

T1

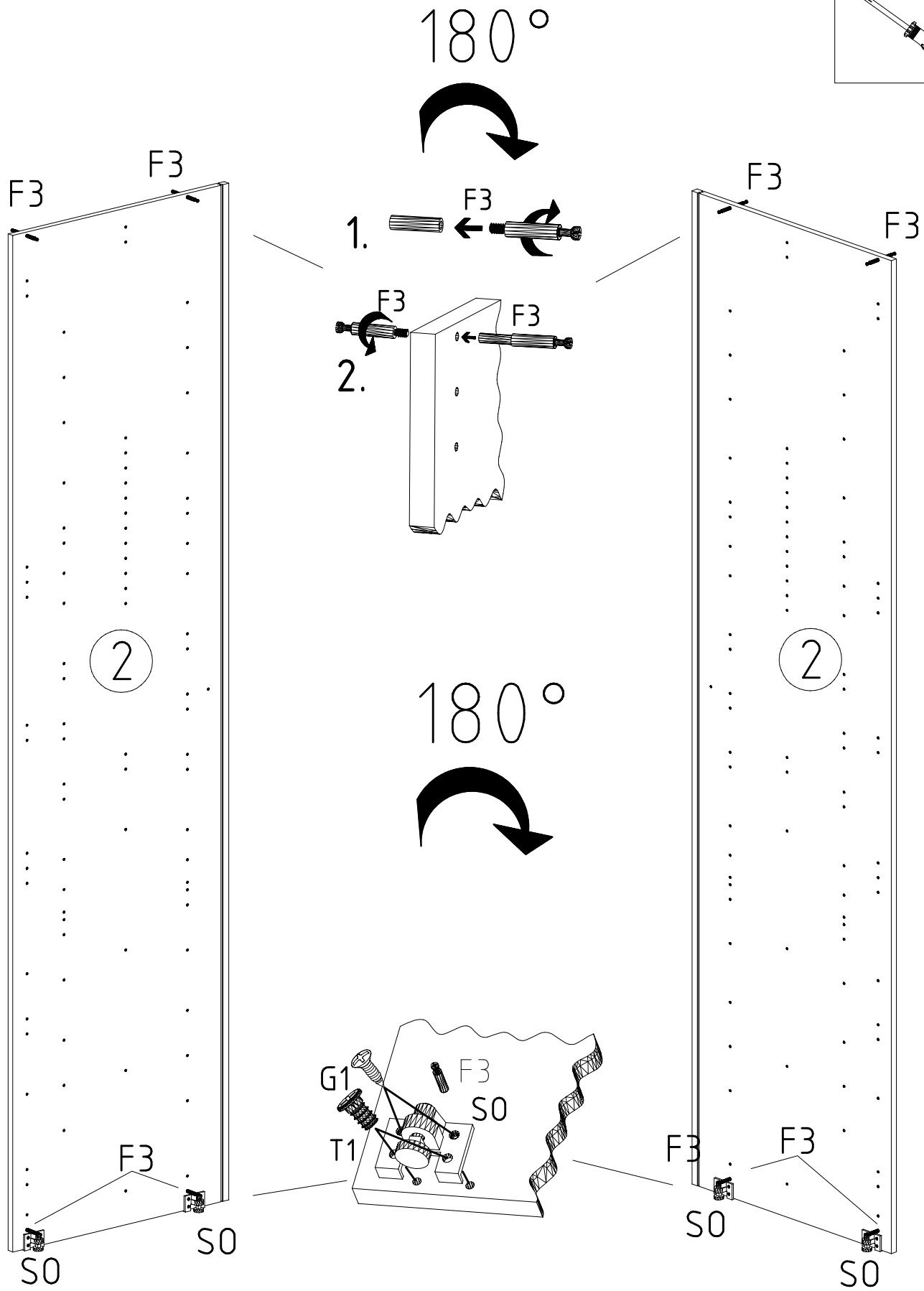
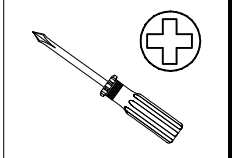

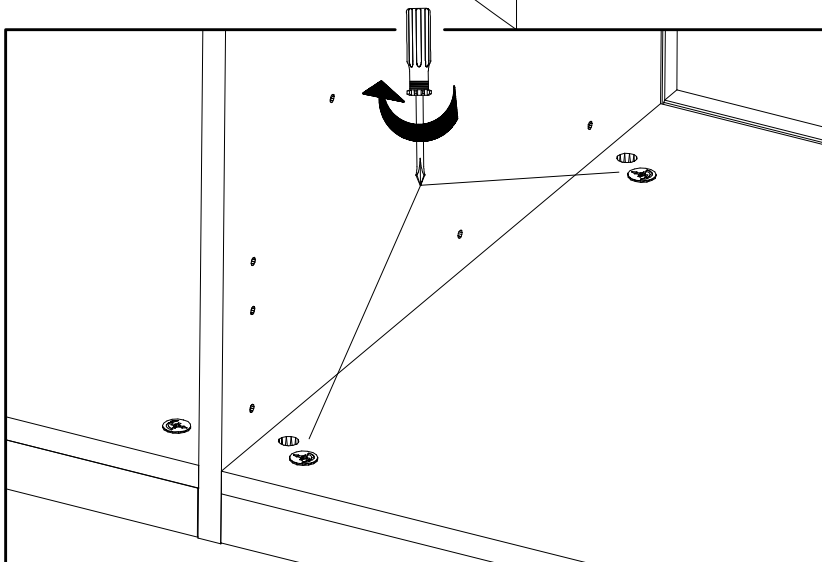
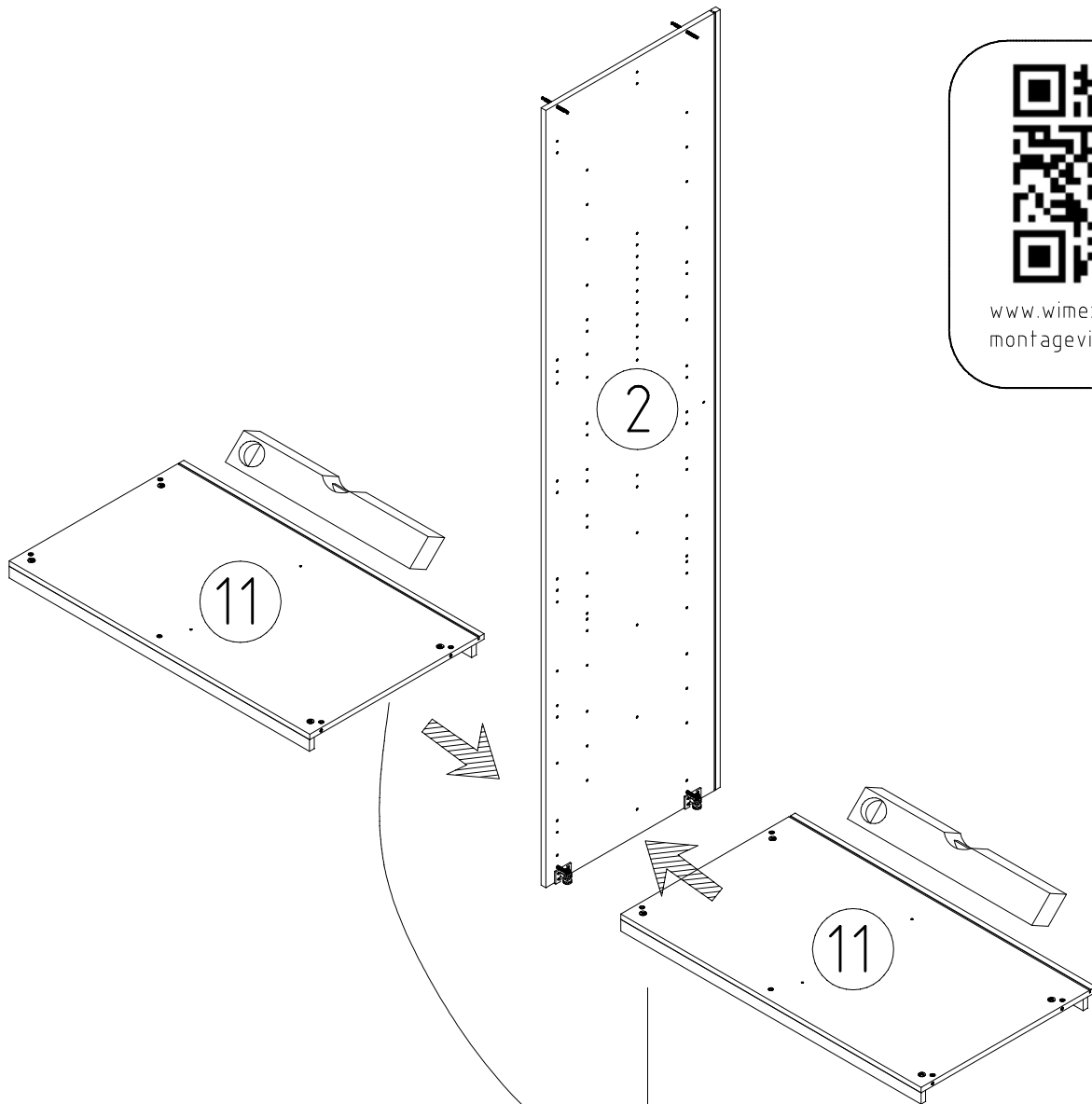
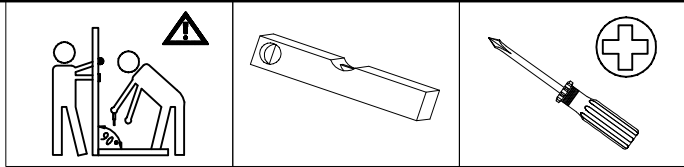
 <p>F3</p>	<p>3,5 x 15 mm G1</p>  <p>121 370</p>	 <p>S0</p> <p>111 300</p>	<p>6,3x10,5 T1</p>  <p>112 055</p>
--	---	---	--

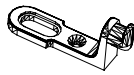

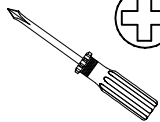



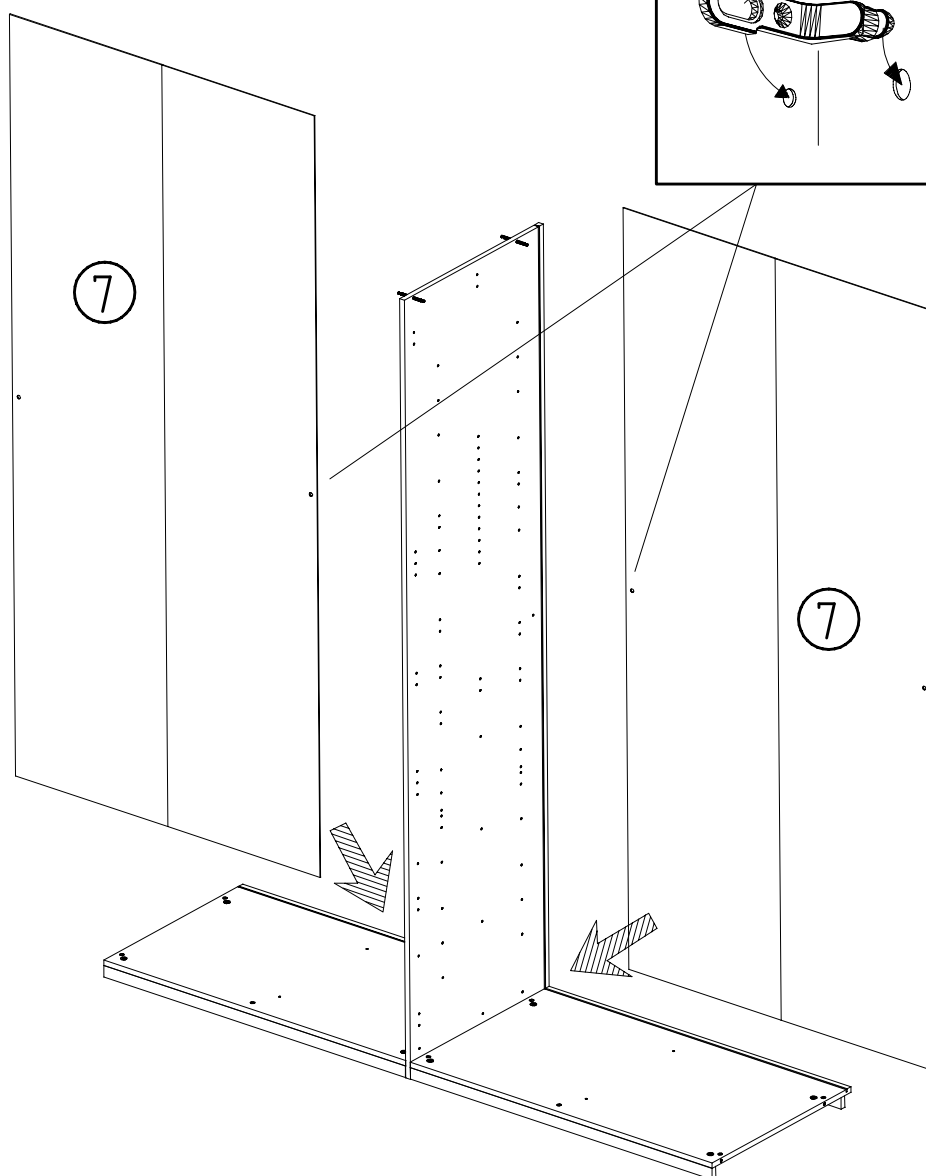
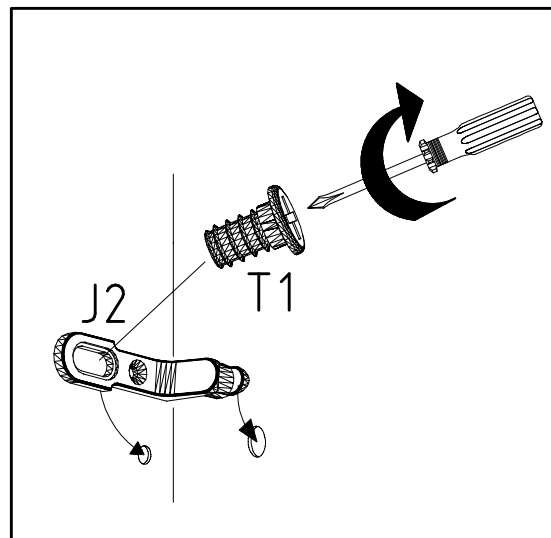

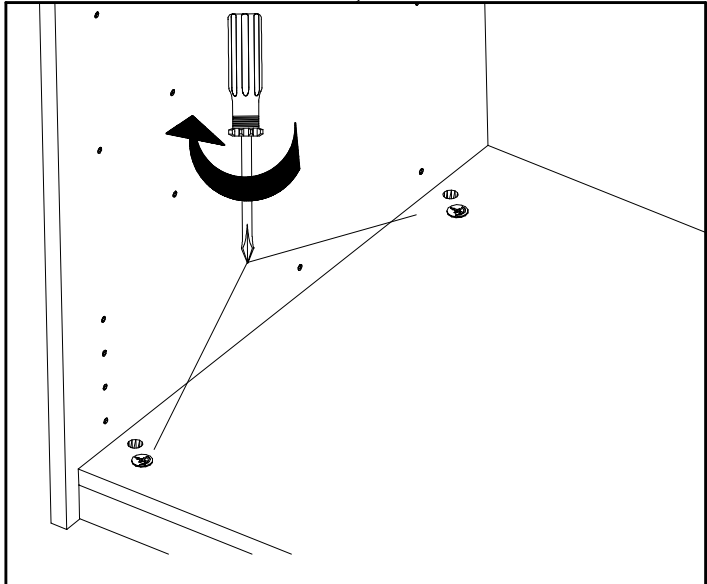
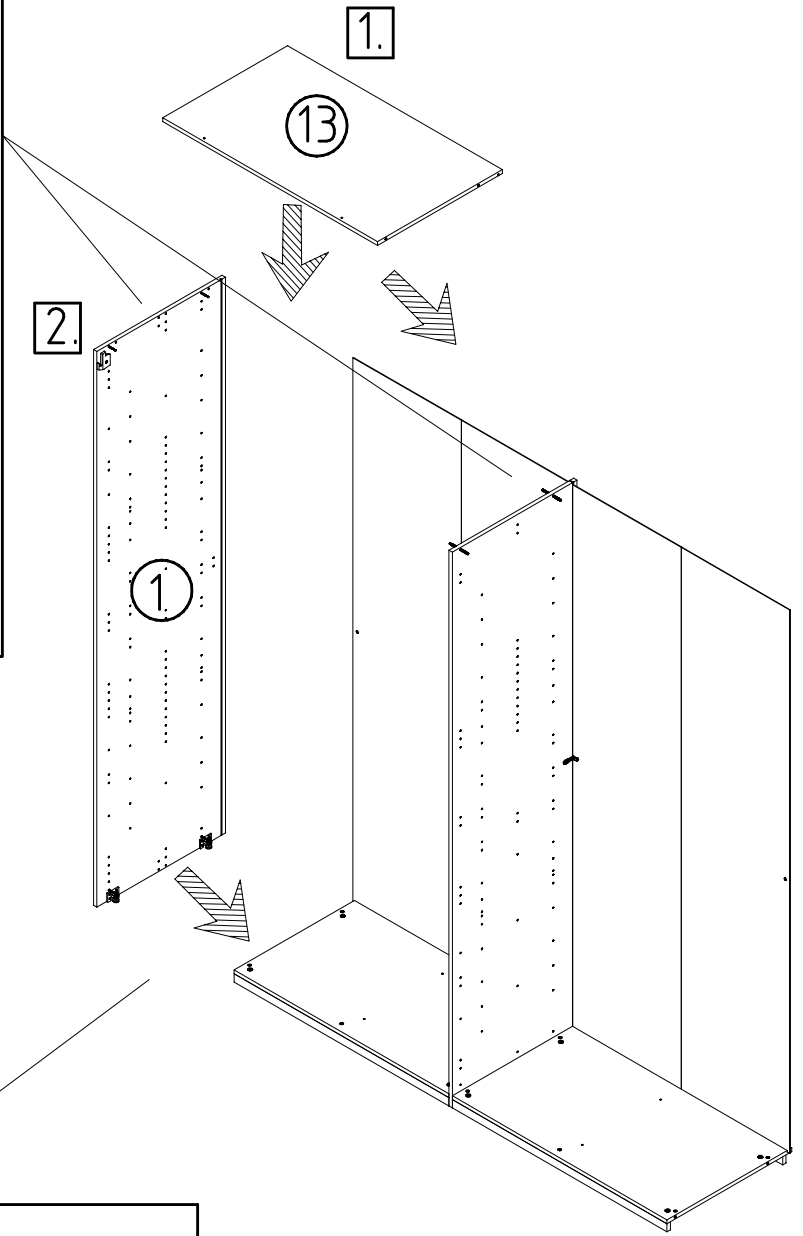
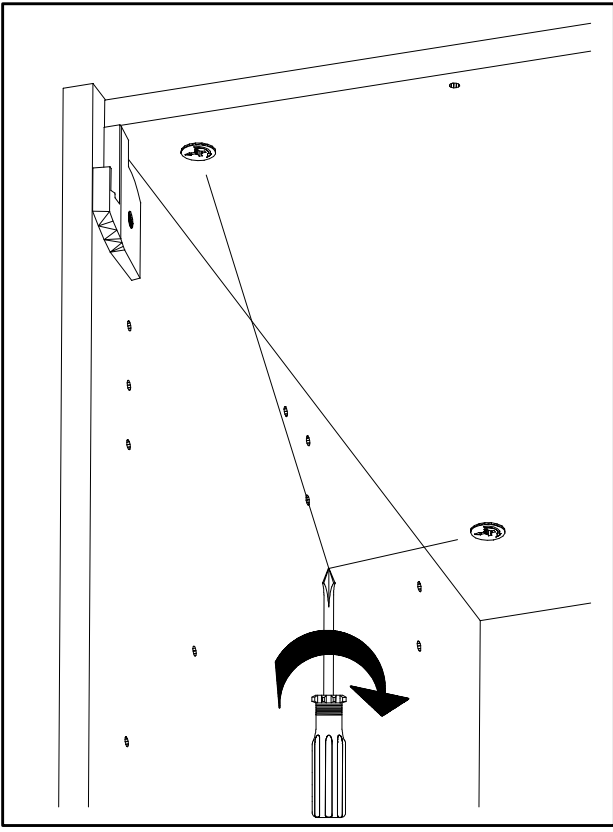
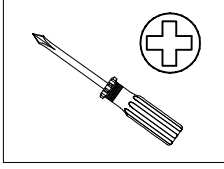
<p>J2</p>  <p>111 611</p>	<p>6,3x10,5</p>  <p>T1</p> <p>112 055</p>	 
--	---	---

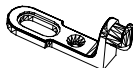

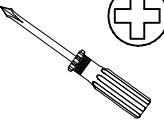



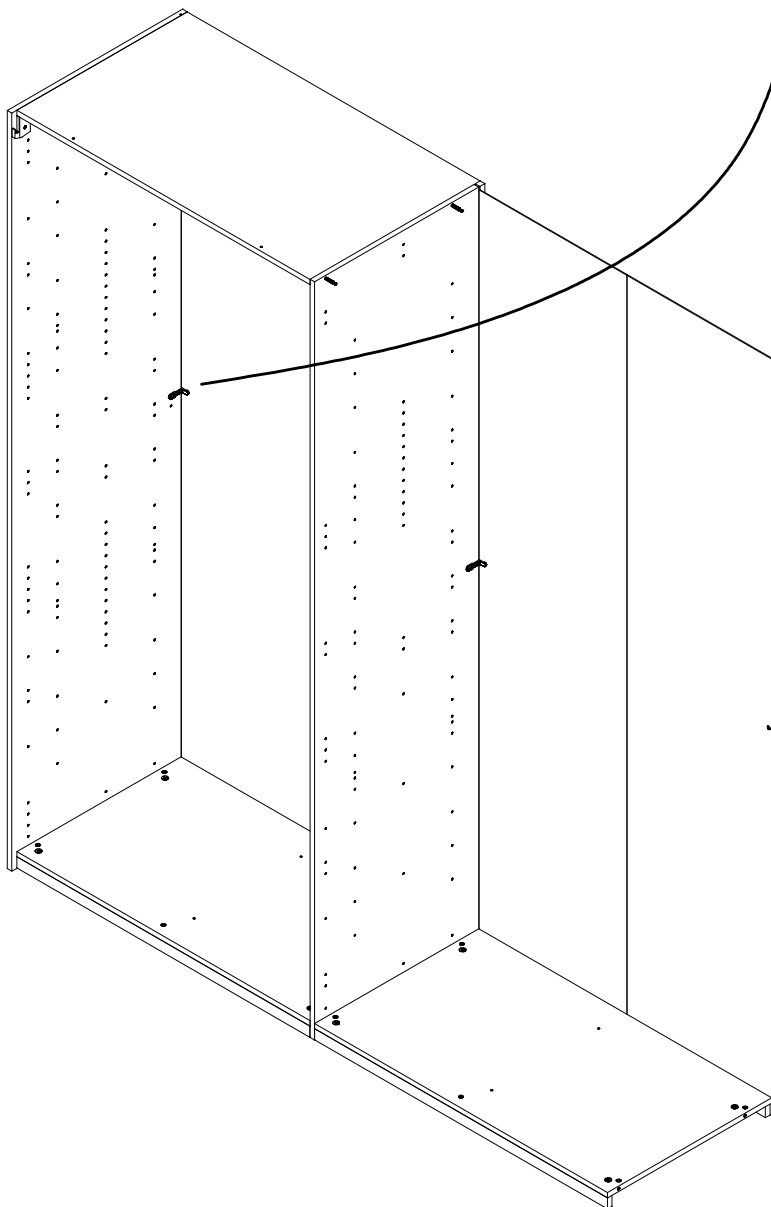
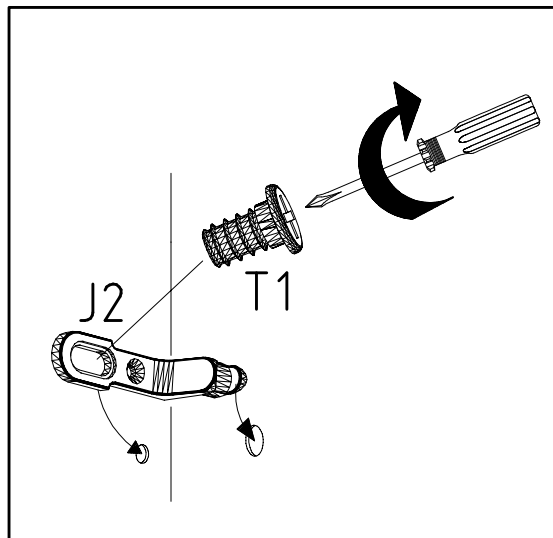

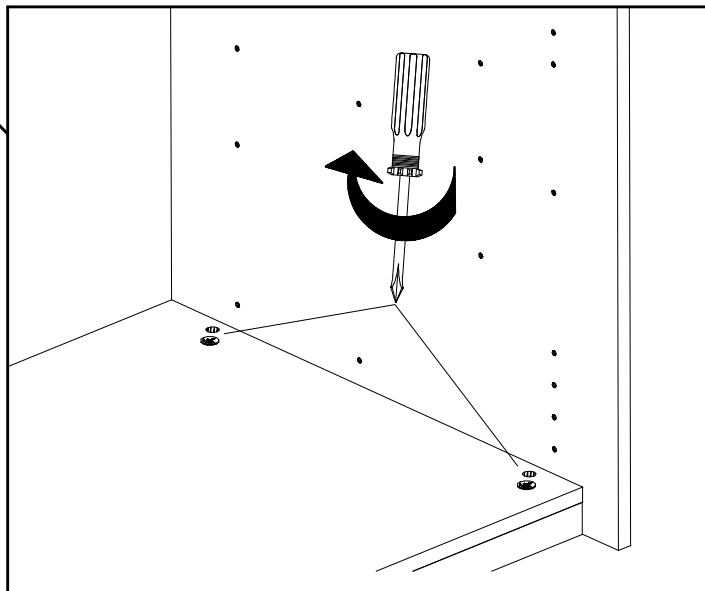
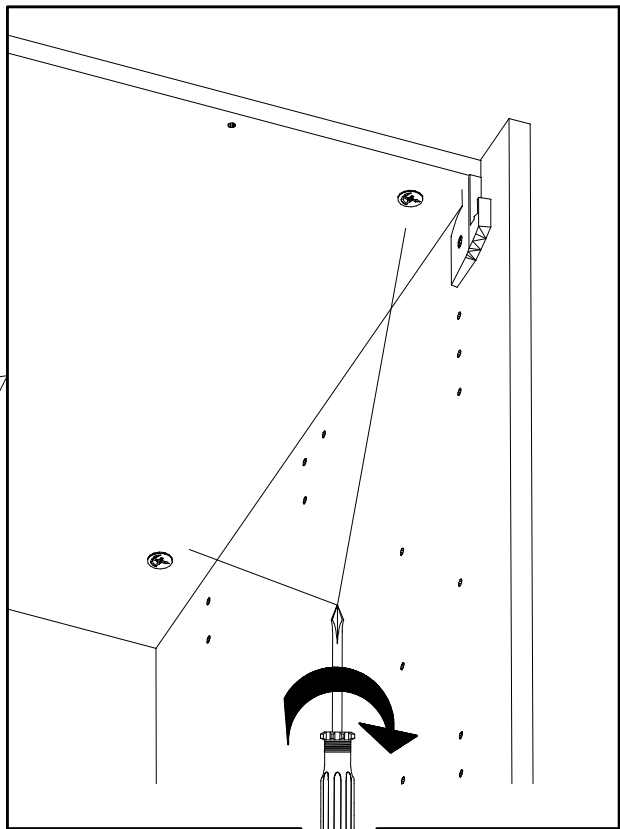
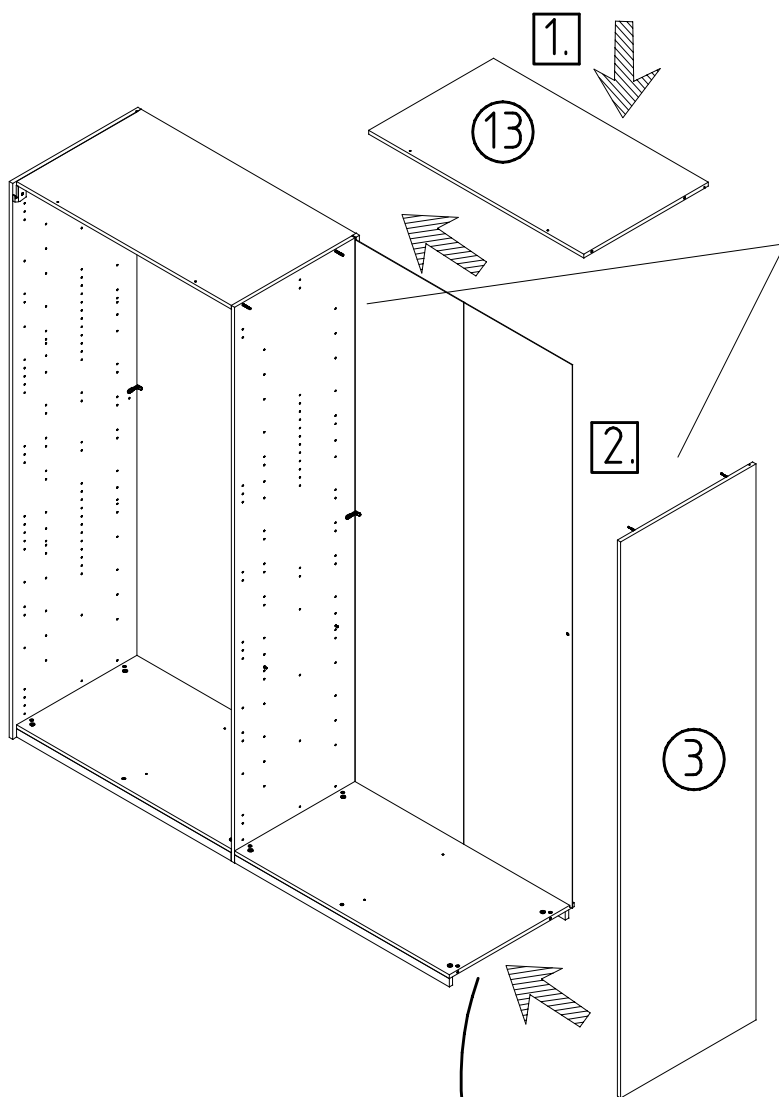
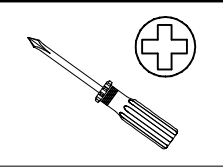
<p>J2</p>  <p>111 611</p>	<p>6,3x10,5</p>  <p>112 055</p>	<p>T1</p>  
--	---	---

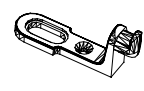

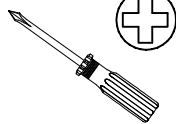

<p>J2</p>  <p>111 611</p>	<p>6,3x10,5</p>  <p>T1</p> <p>112 055</p>	 
--	---	---

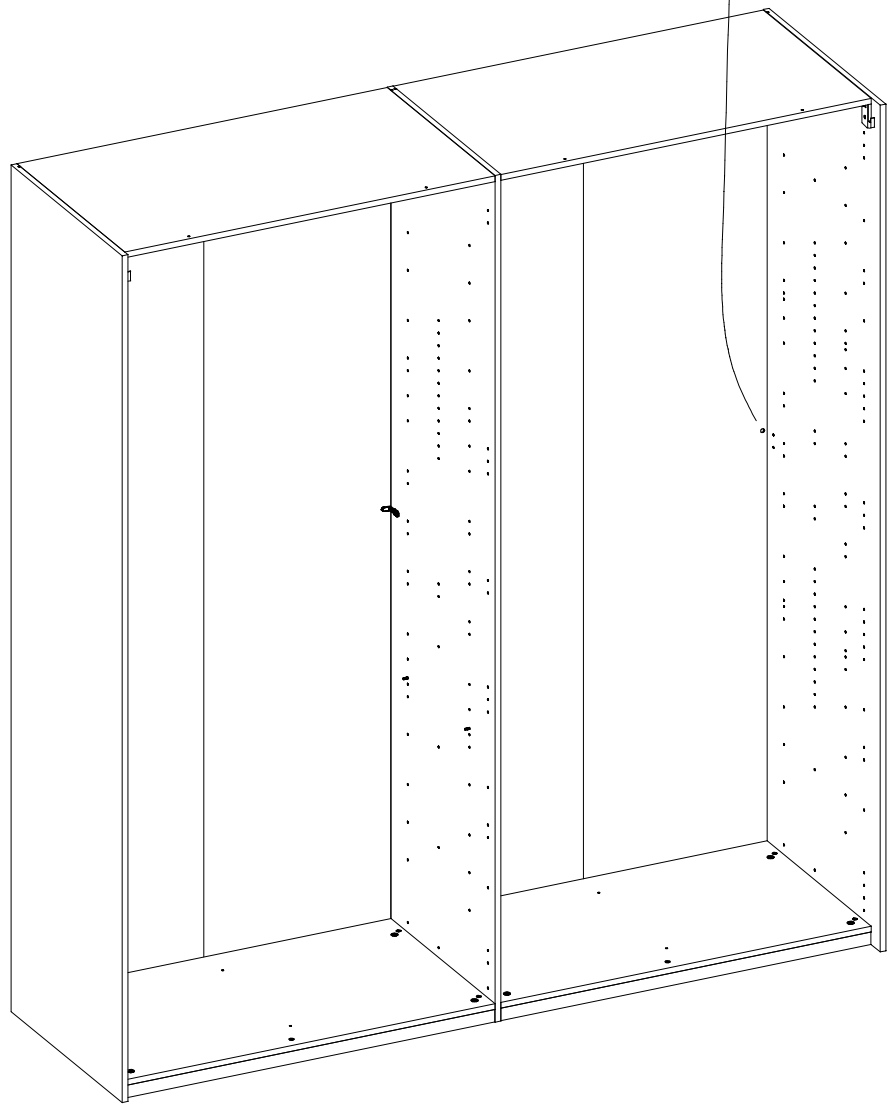
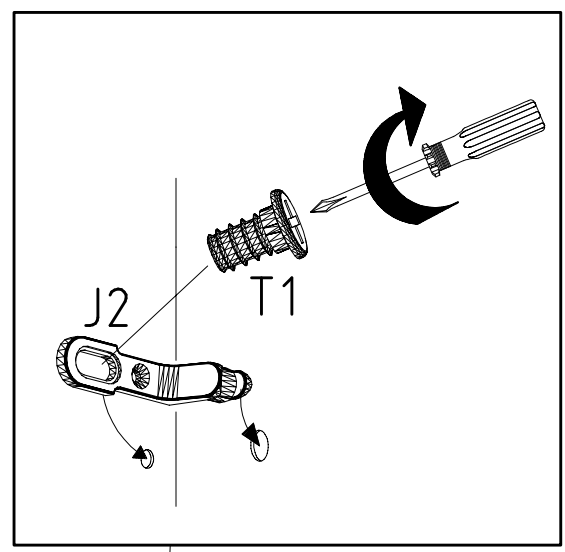

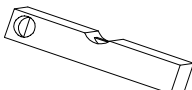
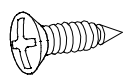
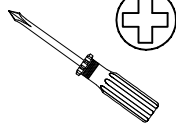
	<p>3,5 x 15 mm G1</p>  <p>121 370</p>	
---	---	--



www.wimex-online.com/
montagevideo/582020.mp4

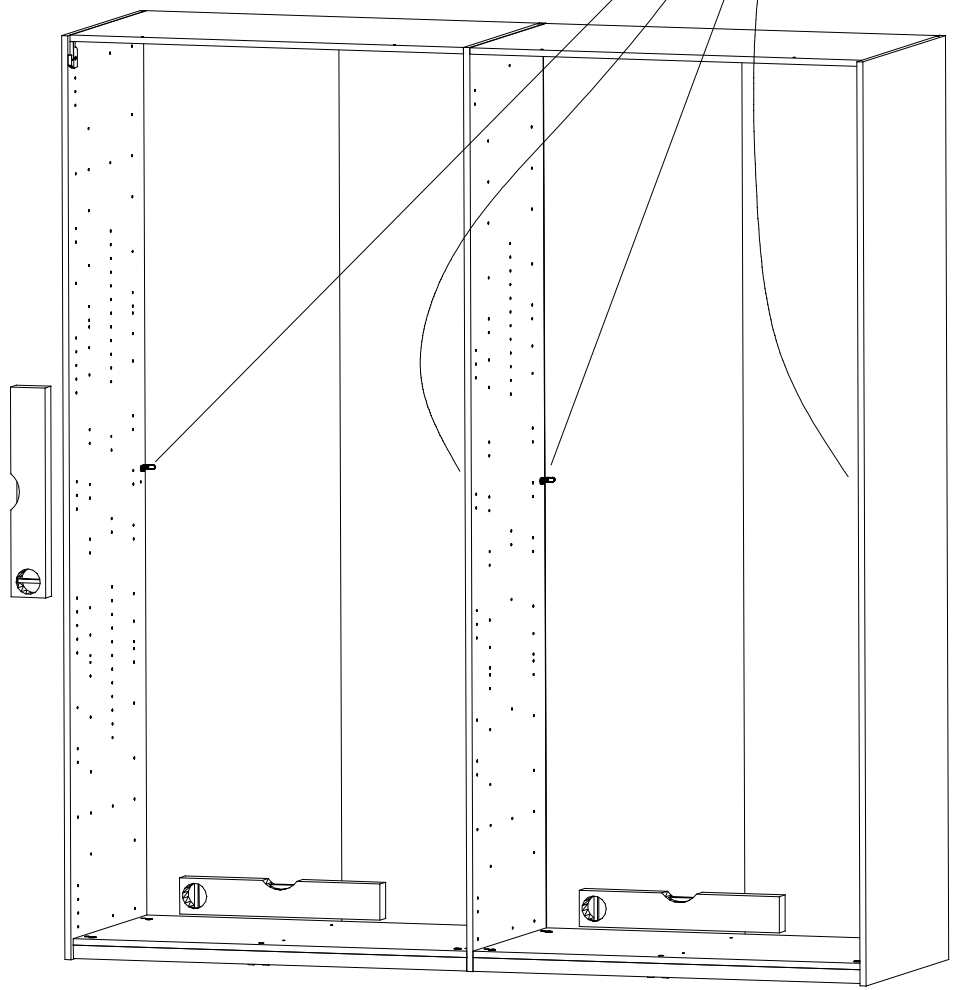
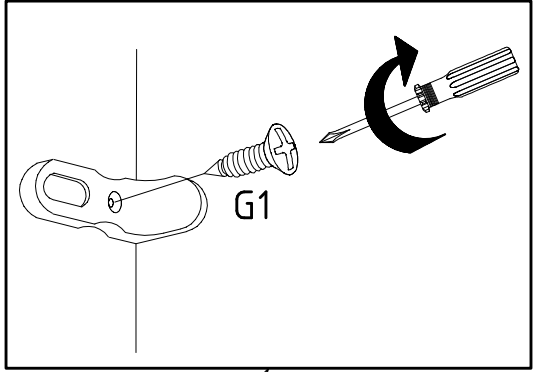
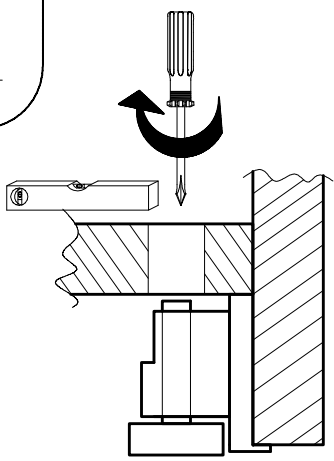

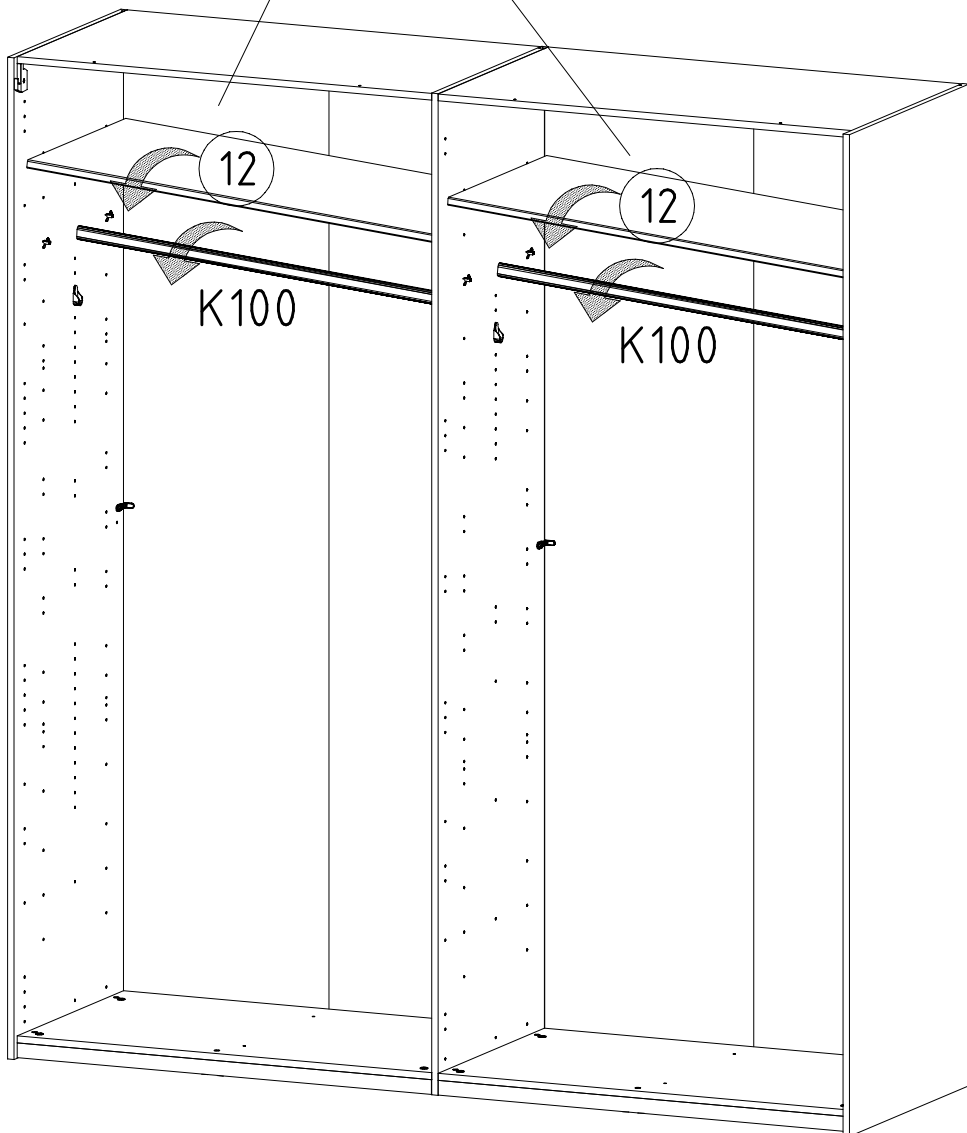
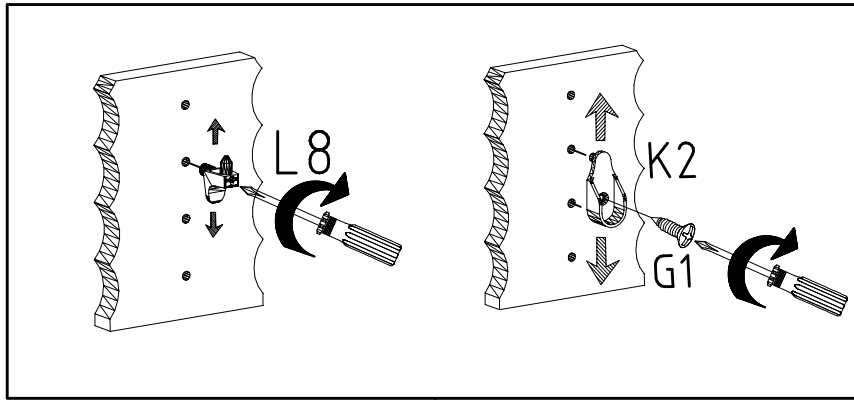
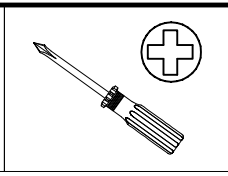
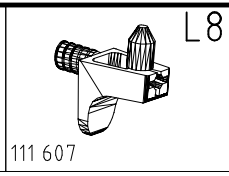
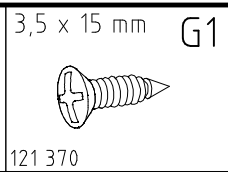
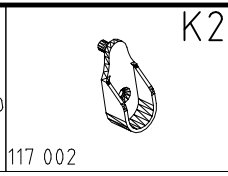
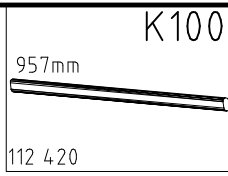

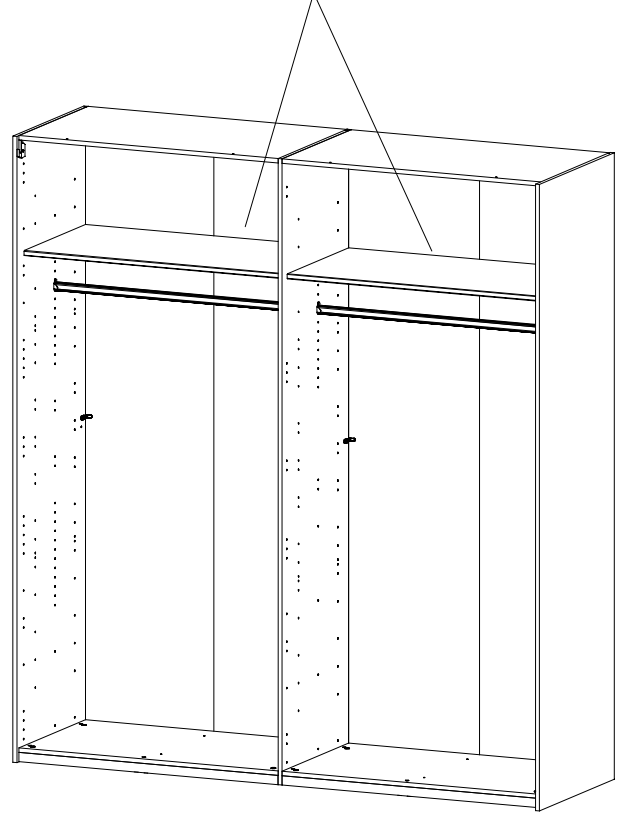
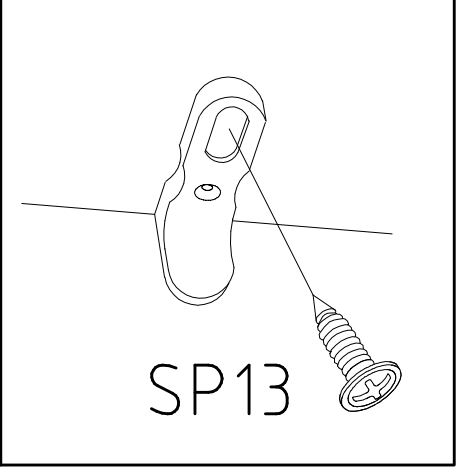
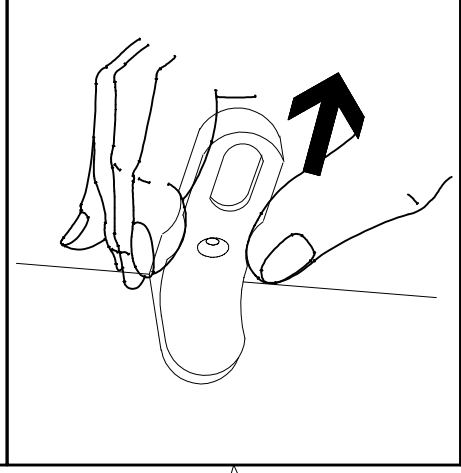
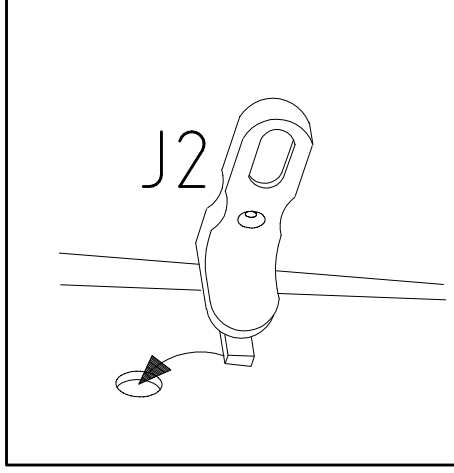
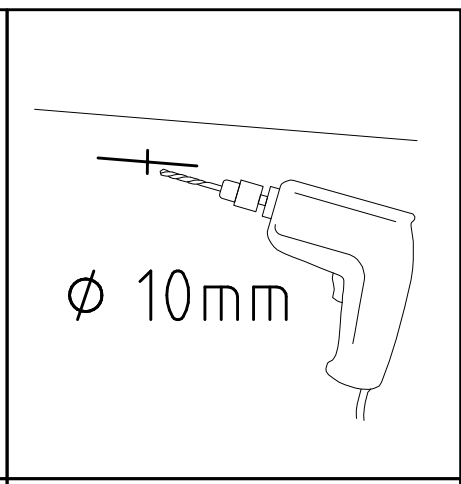
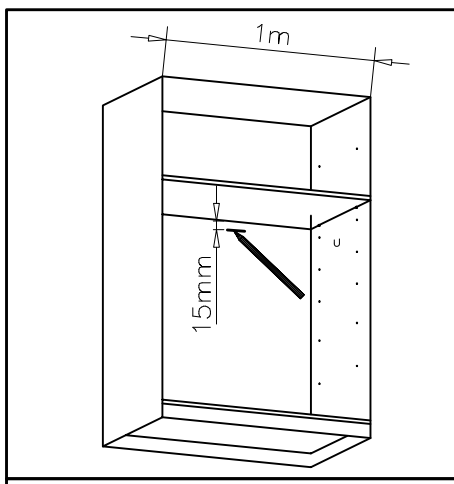
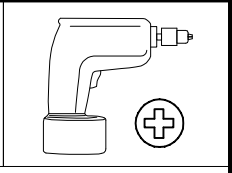
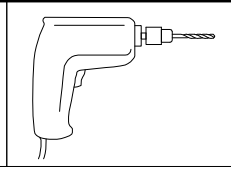
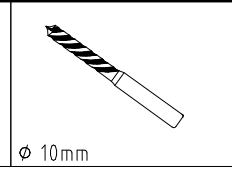
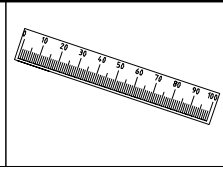
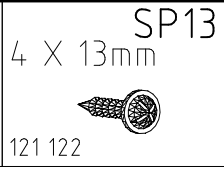
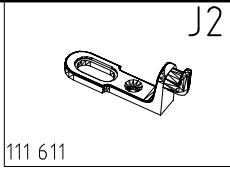

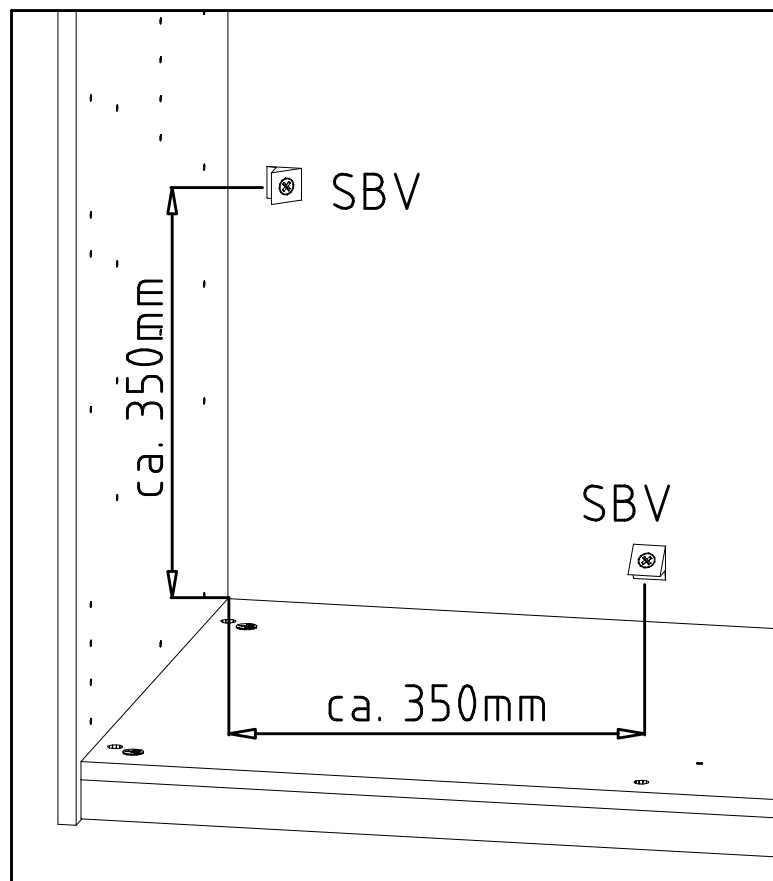
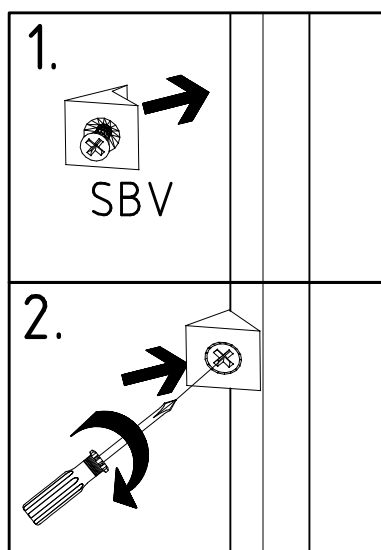
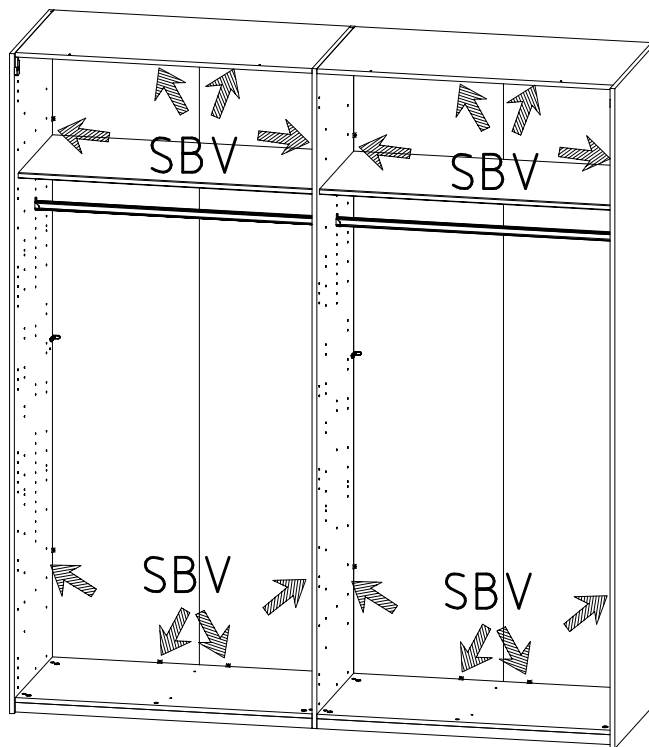



111 xxx

Ø12

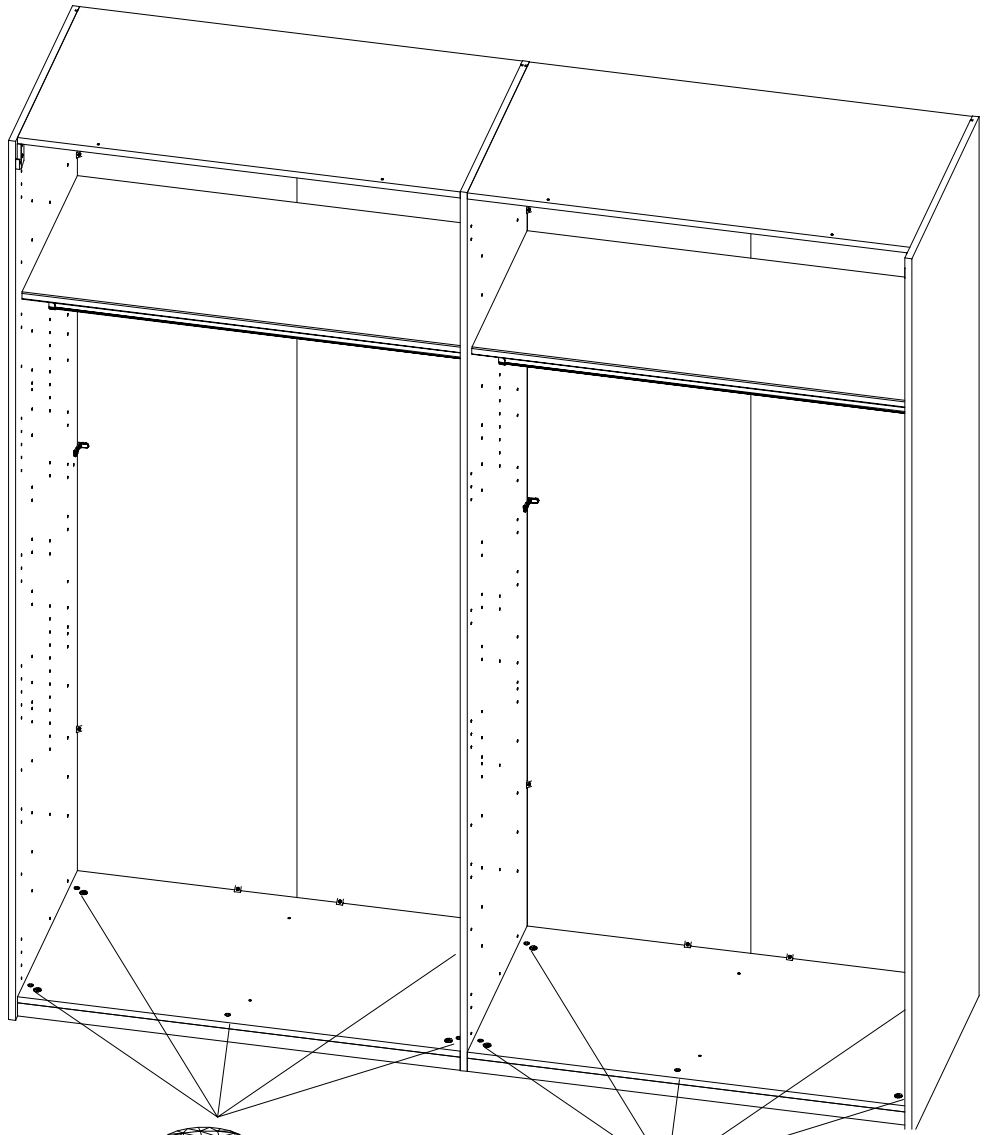

V12

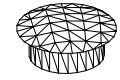

V12

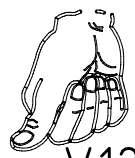

V12

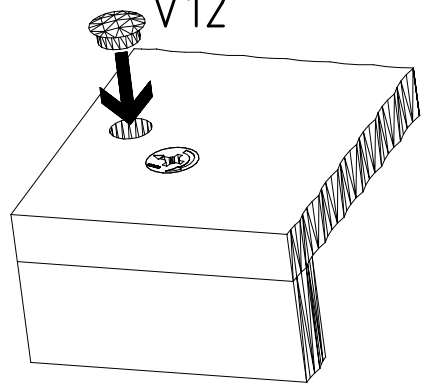

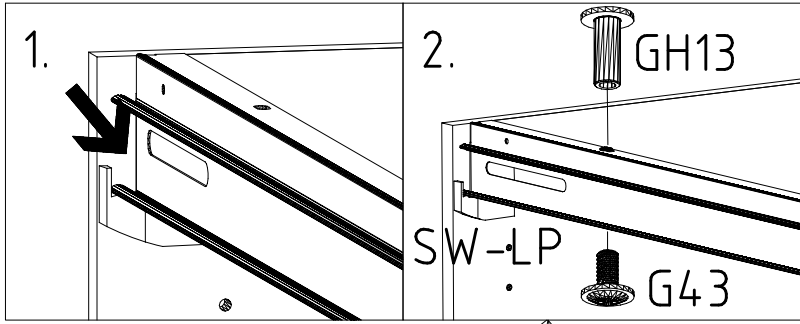



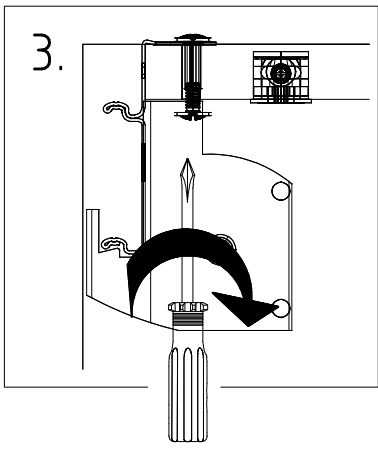
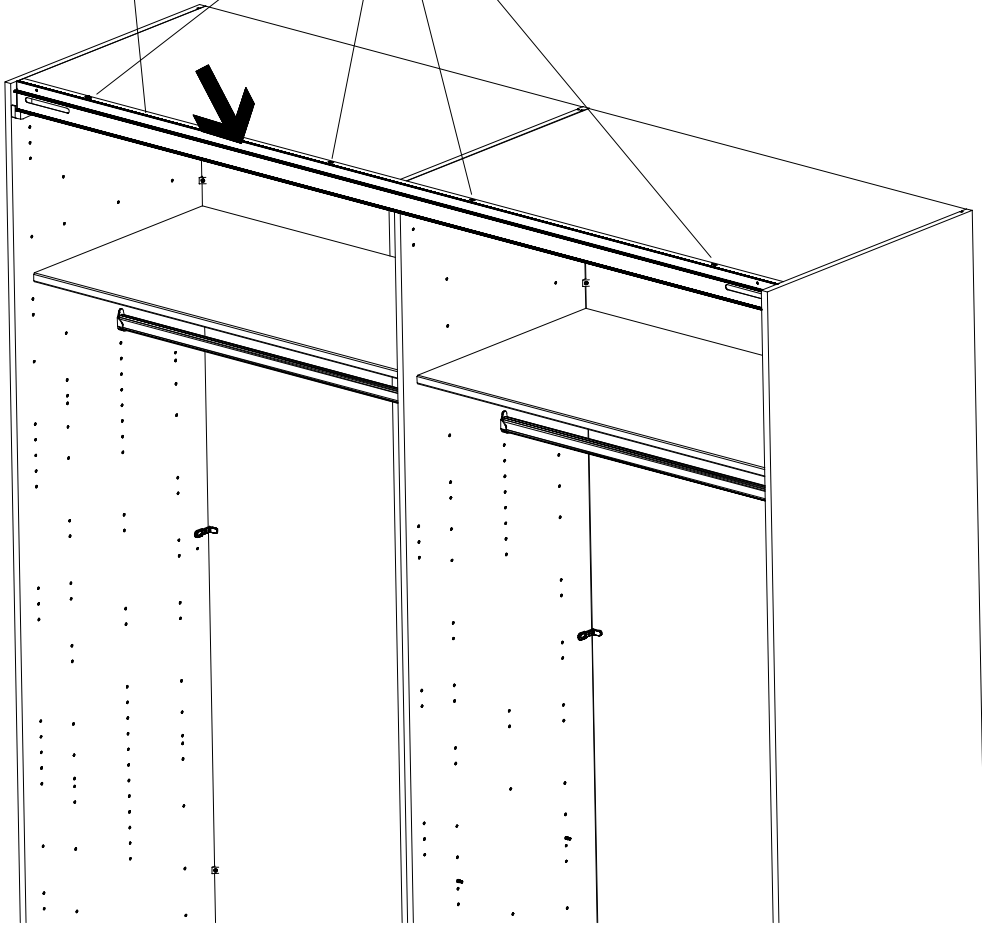

 G43 M4x10	
 GH13 M4x13 PZ	 SW-LP L=1941

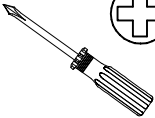
SW-LP
L=1941 mm



 	<p>SP13 4 X 13mm 121 122</p> 	<p>SW-SKM</p> 
--	--	--

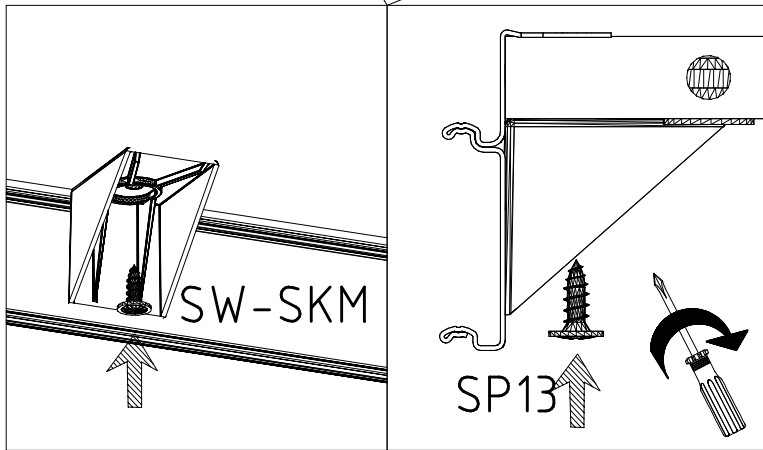
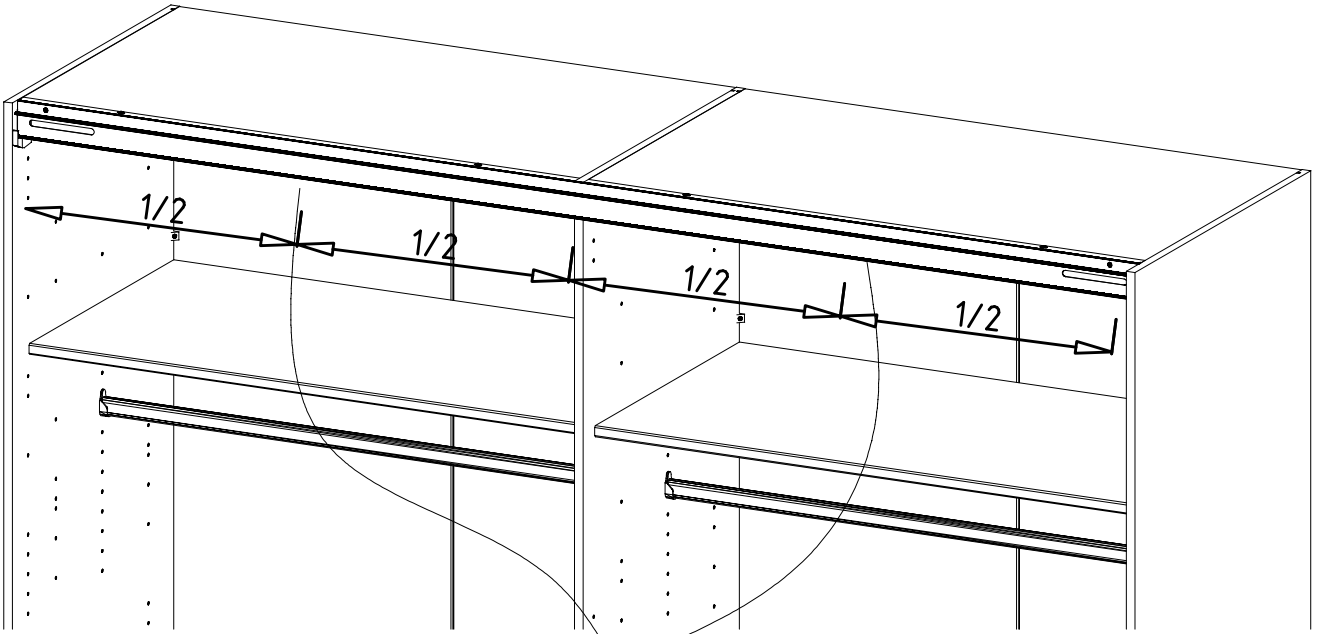

26

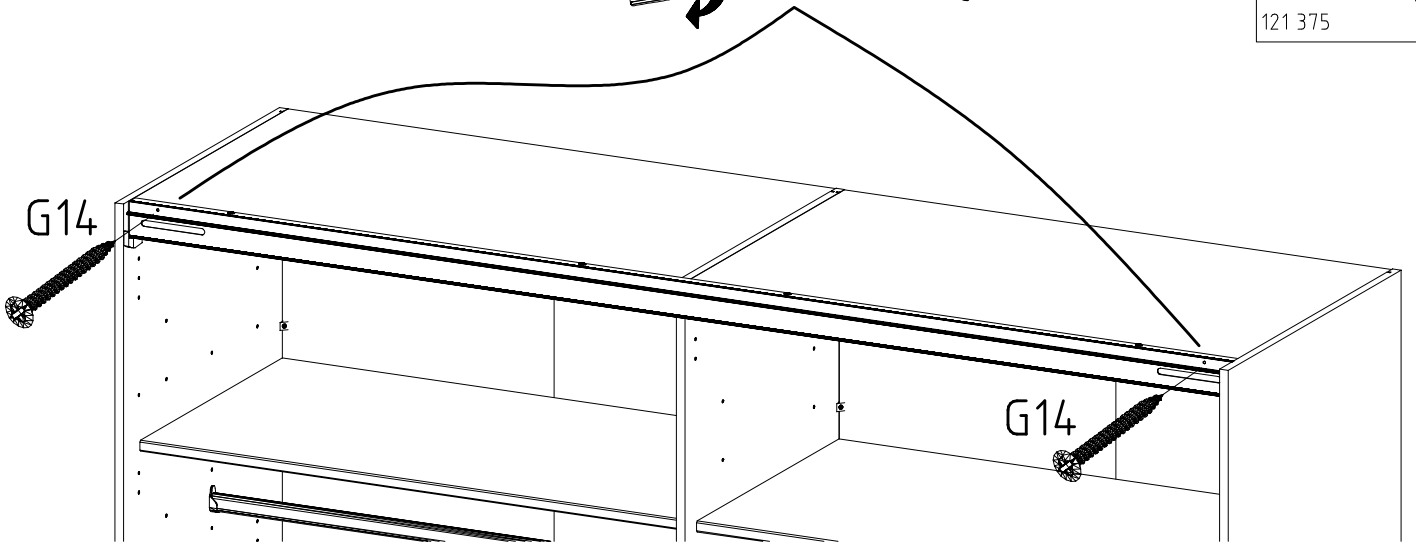
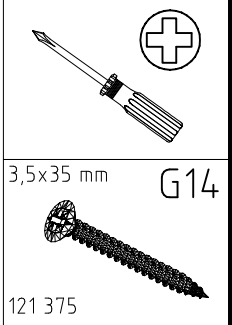
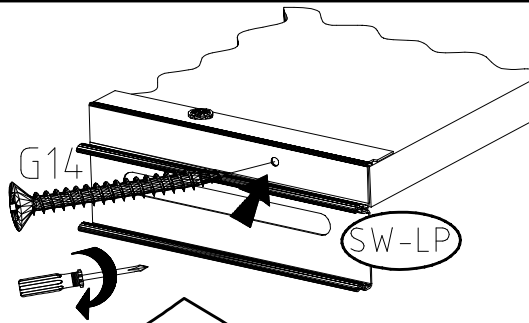
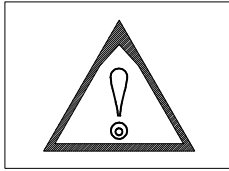

27

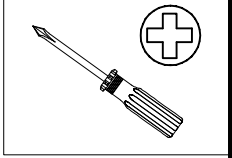
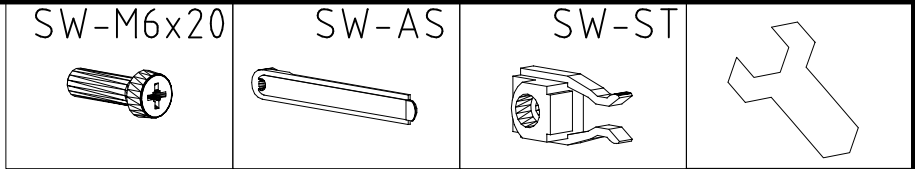

SW-AS
SW-M6x20
SW-ST

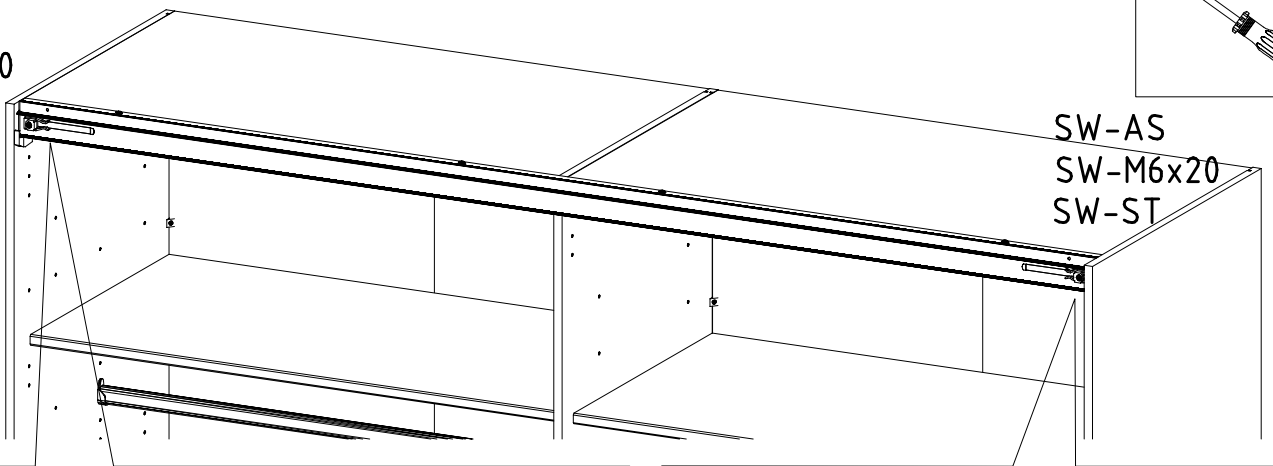

SW-AS
SW-M6x20
SW-ST

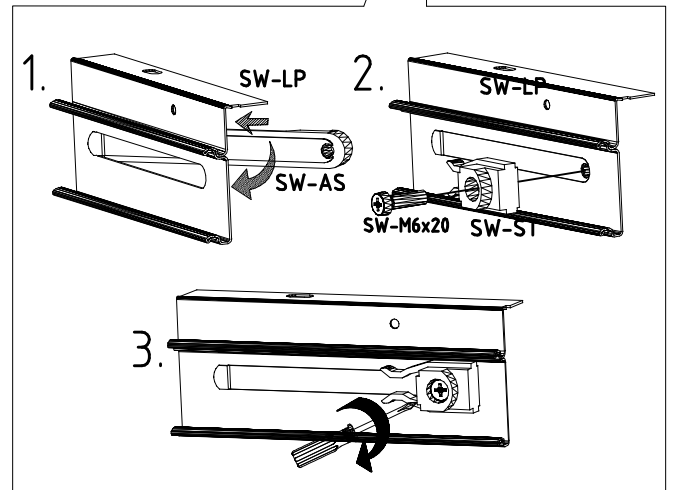
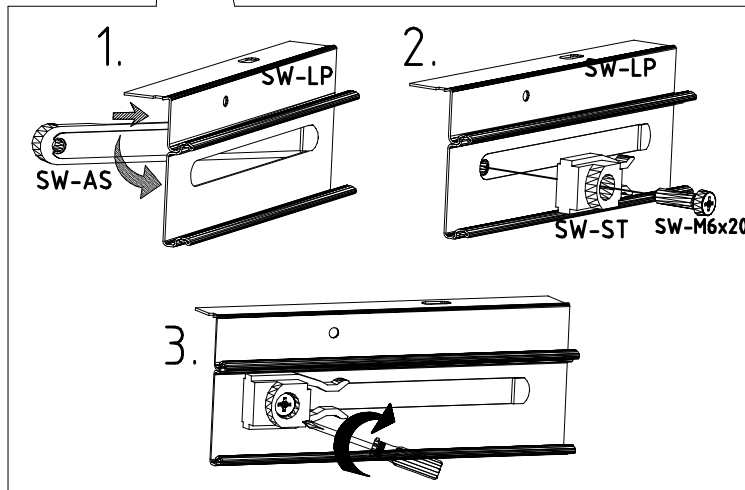

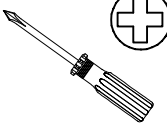
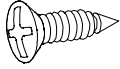
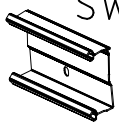
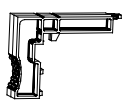
 +	3,5 x 15 mm G1  121 370	SW-FP  L= 1941mm	SW-MH 
---	---	--	---

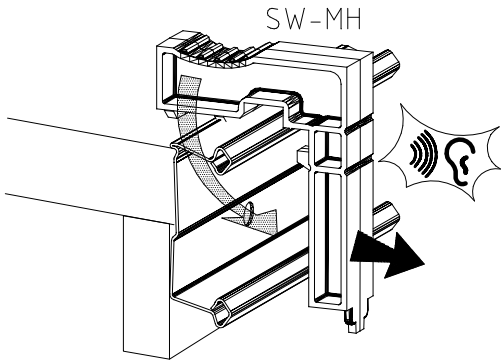
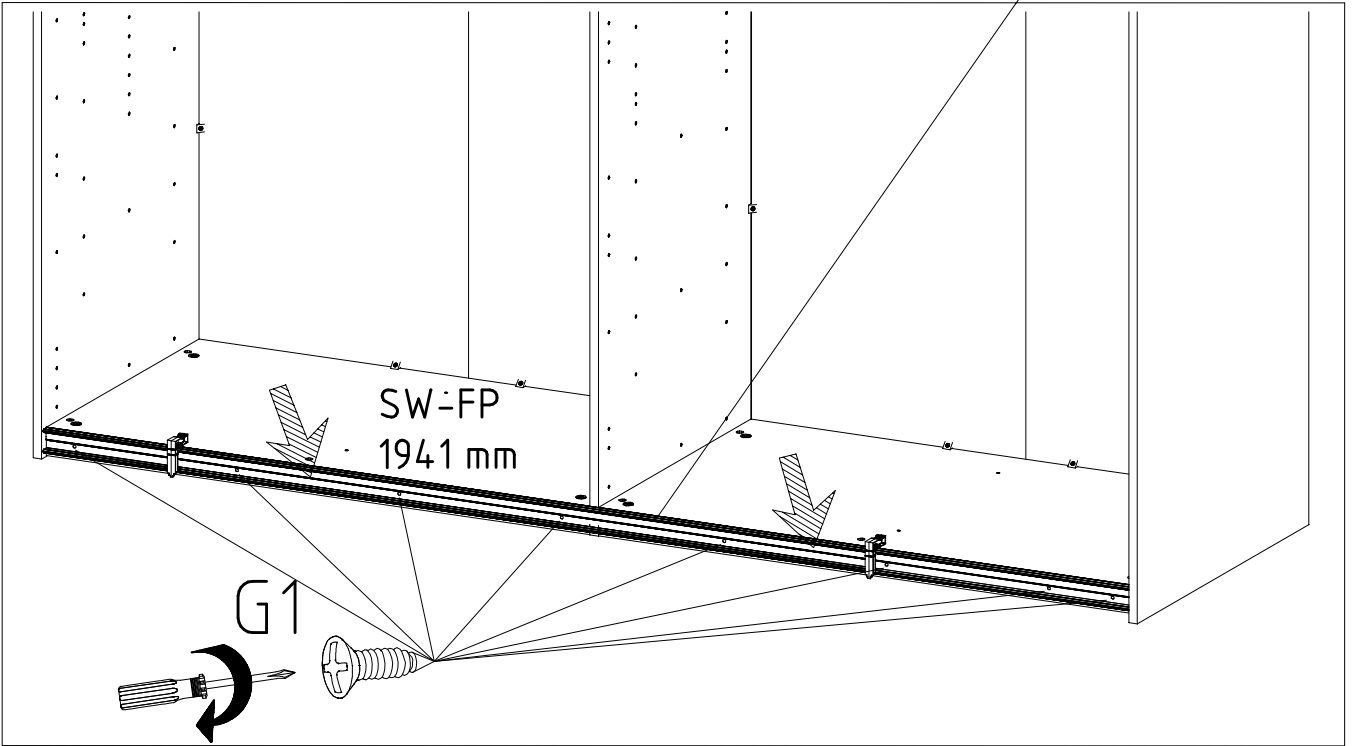
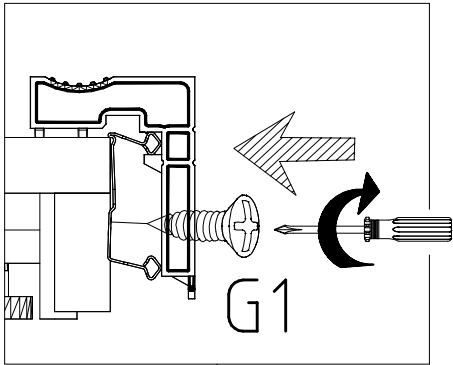
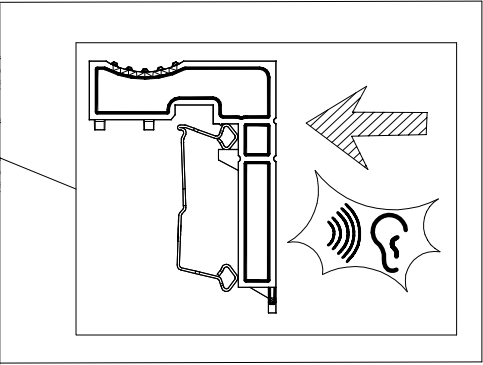
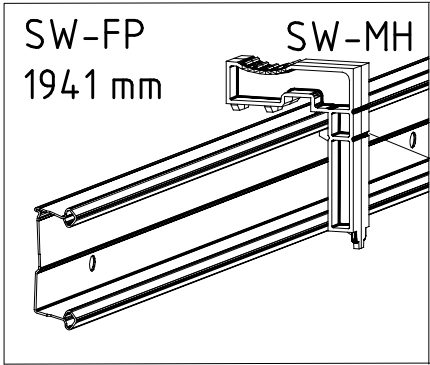

29

I.

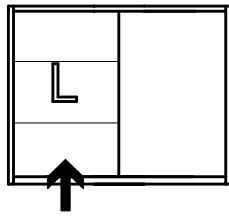
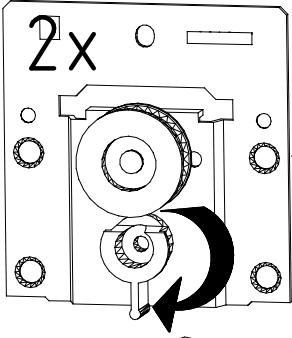

II.

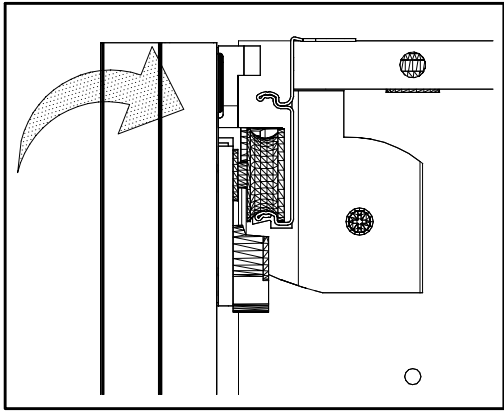
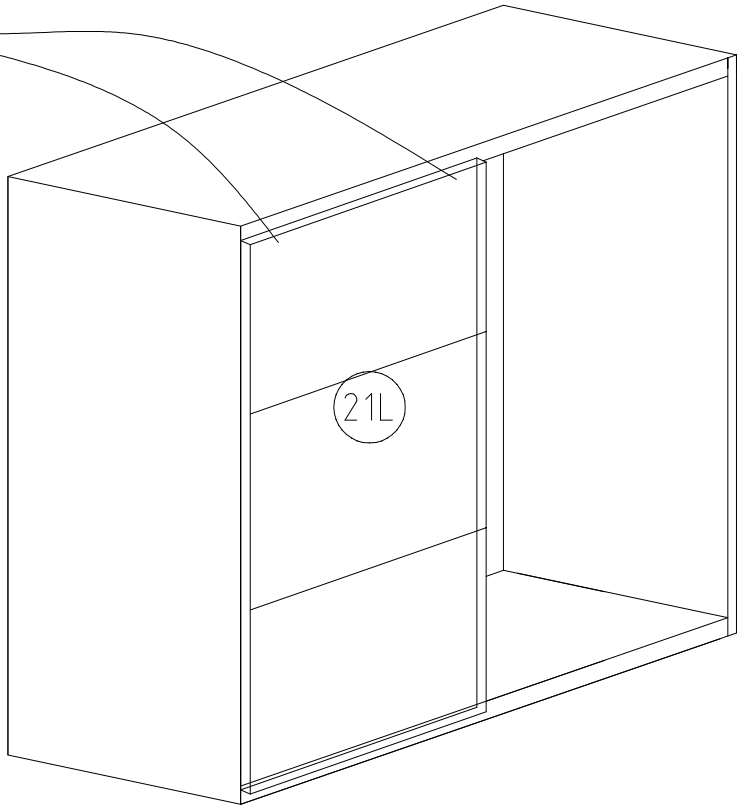
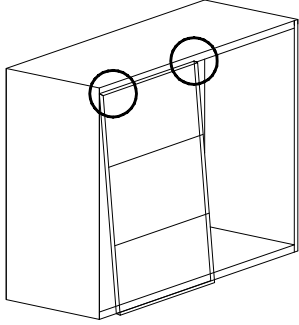

III.

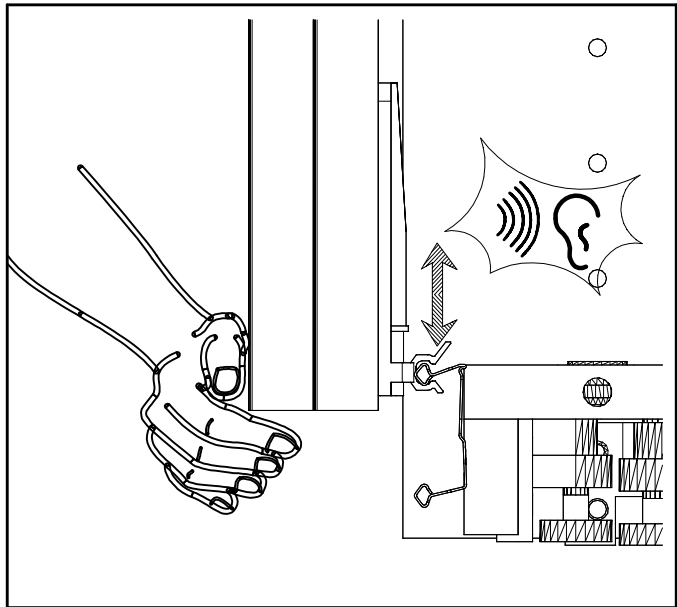
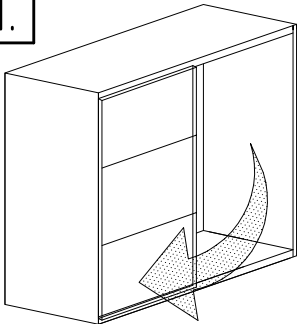

IV.

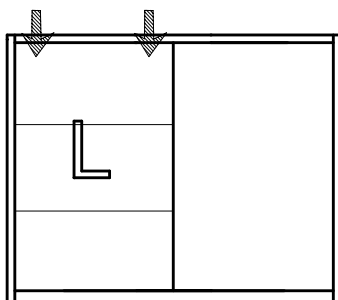
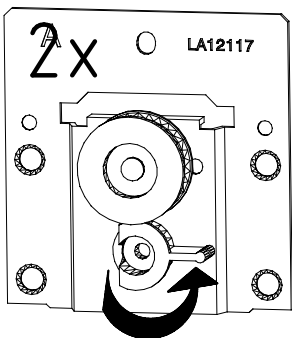

30

I.

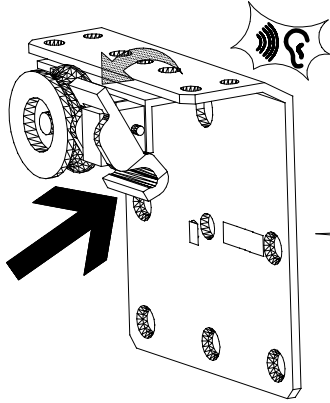

2x

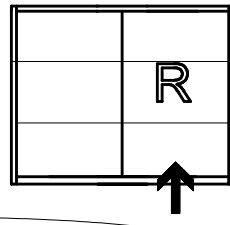

II.

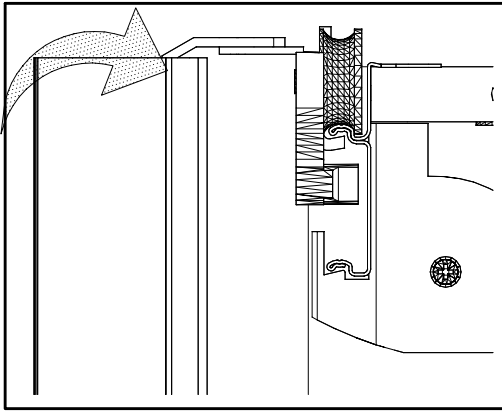
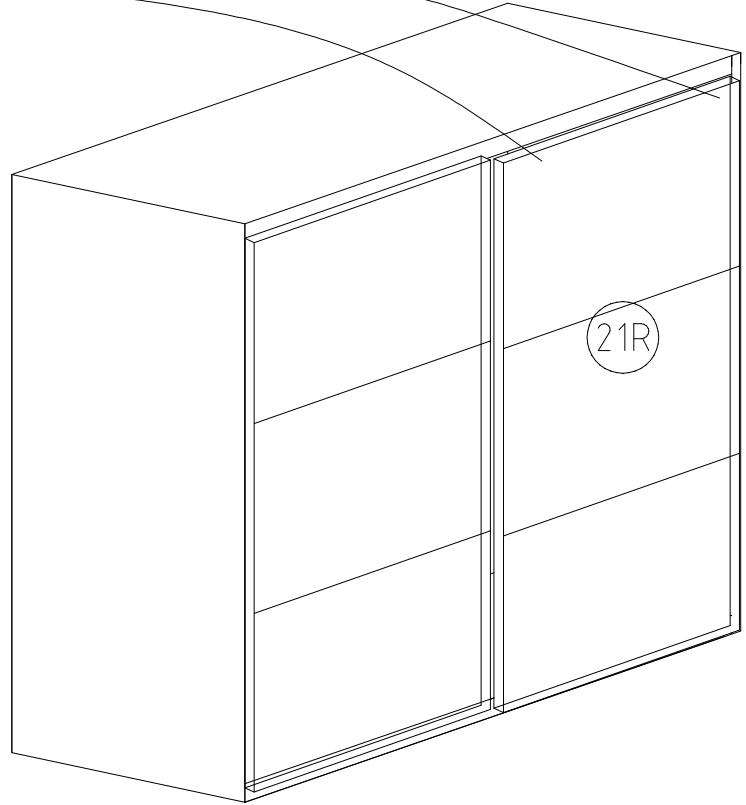
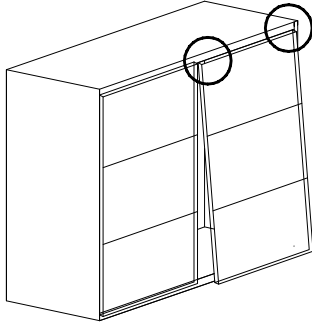

III.

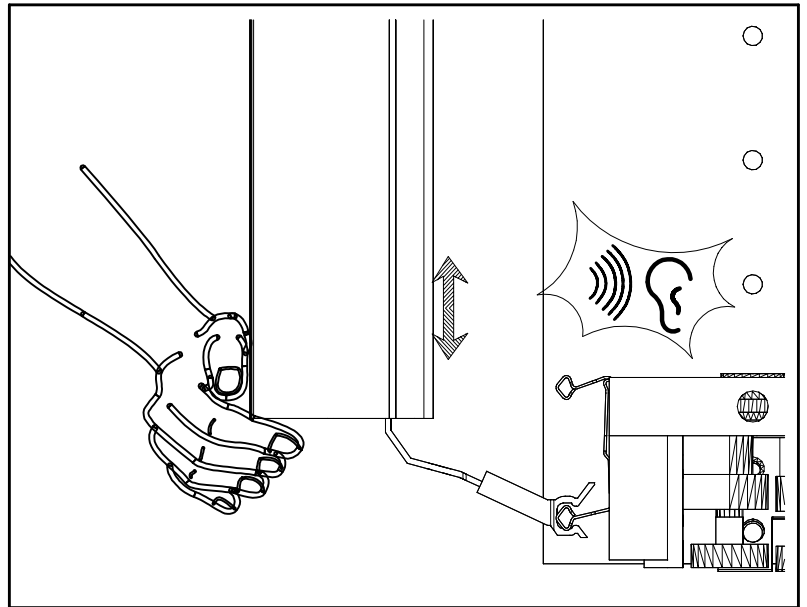
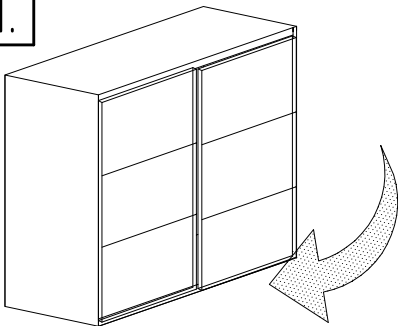

IV.

2x

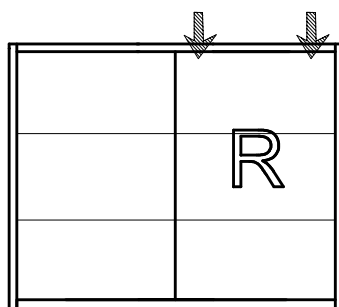
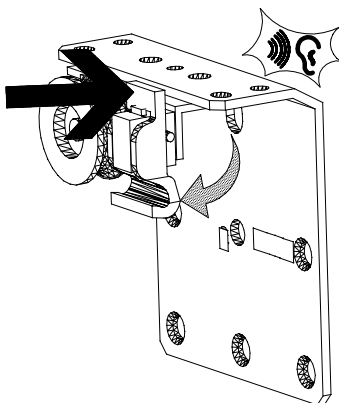

31

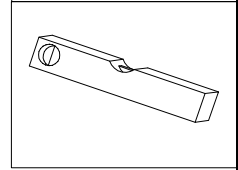
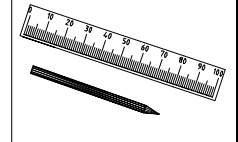
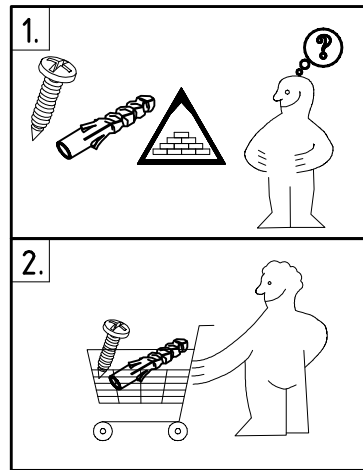
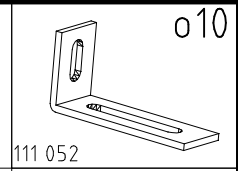
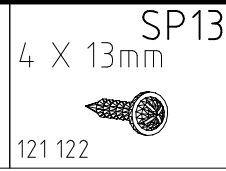
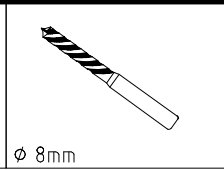
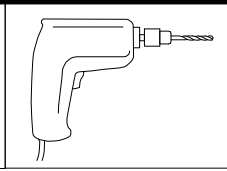
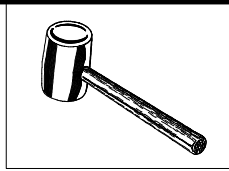

1.

2.

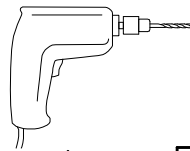
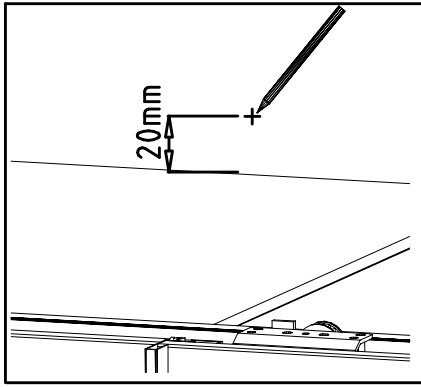

3.

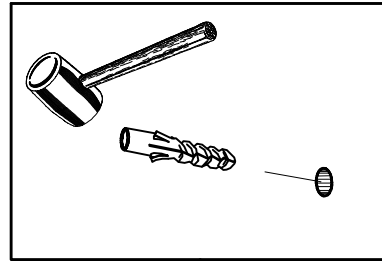

4.

1.

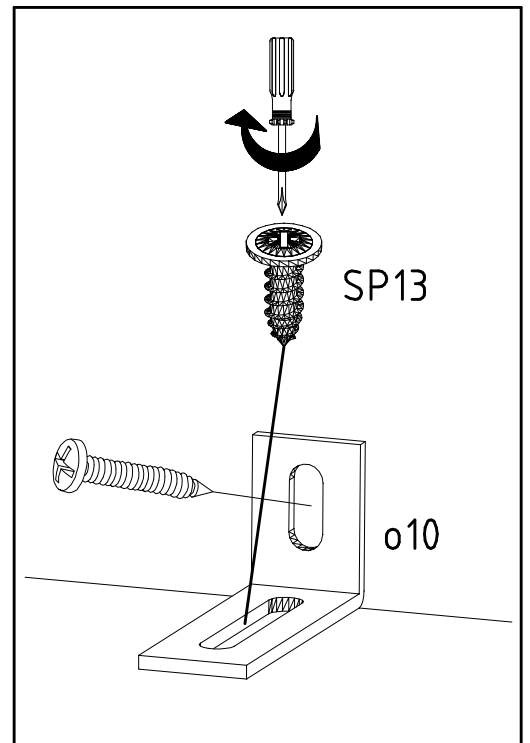
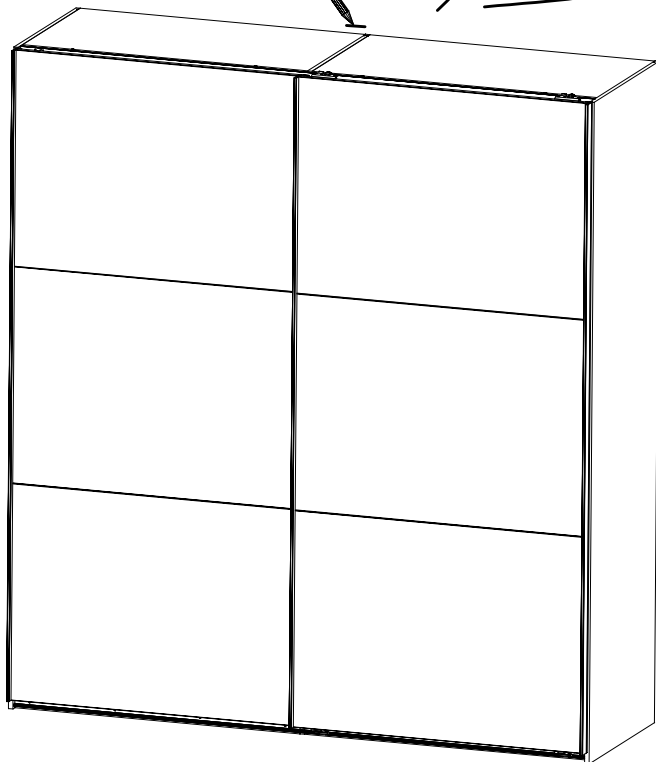

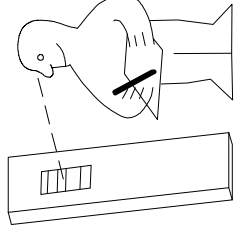
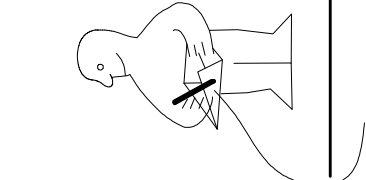
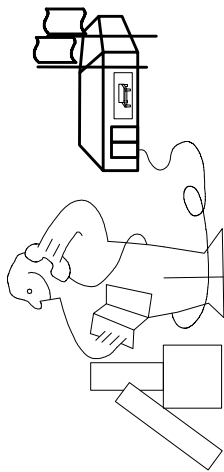
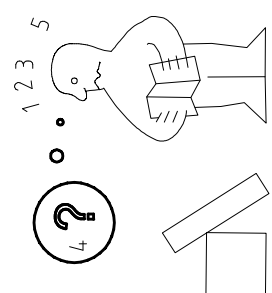

Modell/Modiel/Modèle



--	--	--	--	--	--

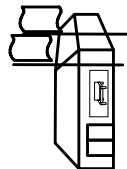

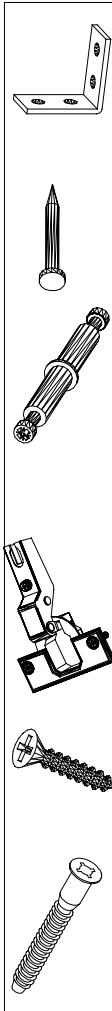

<121 370>	< G 1 >	<4x>

Änderungen die dem technischen Fortschritt geschuldet sind, behalten wir uns vor!
 Bei nicht vorschriftsmäßiger und/ oder nicht fachmännischer Montage wird bei Personen- und/ oder Sachschäden keinerlei Haftung übernommen.

made by

WIMEX Wohnbedarf Import Export Handels GmbH & CoKG/ Postfach 14.07 / 49112 Georgsmarienhütte/ Germany

23203	30110XY
Kunde MAX MUSTERMANN Customer client	
Kommission / your order reference / votre reference 3377 MINDEN	
Dekor / Decor / Descrip / Modell / Mode / Modelle F99 SAMPLE F99842 SCHNEIDTUEBENSCHRANK 250 CM H 216CM PLANKENEICHE NB + RAU STEEL PLANKENEICHE NACHBILDUNG	
 202320301107241476000001	
414760 SOCKEL	
Paket / Package / Paquet Paket 1 von 8	Colli Kommission 10
HSP-SWT BOD 50 TEXT/TEX SOCKEL 32 FRESH SO-BOD TEXT RASTEX/ ZWBOD D18MM 1X KLSTA 104	
Montage - Anleitung KS-64 Laenge 520,0 Breite 568,0	
SOCKEL32 KLEB	



104 OBEREN 5 30/19 HAUT 23.08.19 SOFFEN 1/1 ABOVE OBEREN



WIMEX Wohnbedarf	
Import Export Handelsges mbH & Co. KG	
Werner-von-Siemens-Str. 35	
D-49124 Georgsmarienhütte - Germany	
service@wimex-online.com	
SAMPLE	23.08.19
Modellname	Produktionsdatum
Model	Date of manufacture

