

-01

Montageanweisung / Installation instructions / Instruction de montage / Istruzioni di montaggio
montagehandleiding / Instrukcja montazu / Montaj talimatlar / Osszeszerelési útmutatót / Nàvod k montázi /
Nàvod na montaz / Instructiune de montaj / Инструкция по монтажу / Montaj talimatina / Monteringsanvisningar
Upute za montažu / Instrucciones de Montaje / Navodila za montažo

INFINITY 2.0

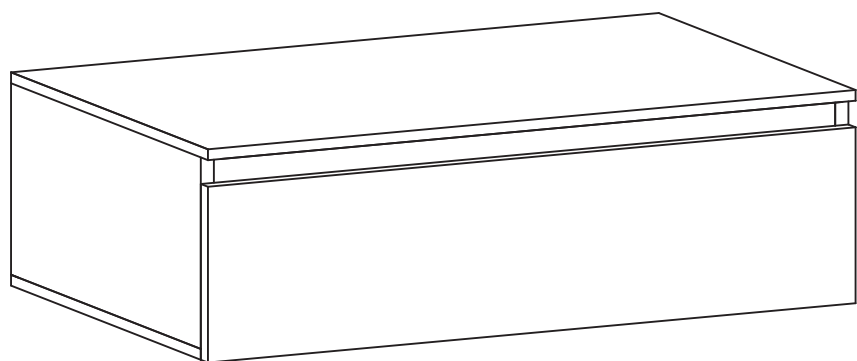
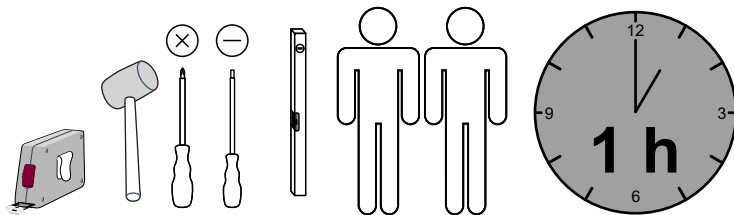

D – bitte lesen sie diese montageanleitung gut durch,
Da wir für fehler, die durch falsche montage entstehen,
Keine haftung übernehmen!

Gb – please read these installation instructions
Through carefully as we cannot accept any liability
For faults occurring as a result of incorrect installation!

Cz – přečtěte si prosím pozorně tento návod k montáži,
Aby jste předešli chybám vzniklých špatnou montáží,
Za které neručíme!

F – veuillez lire attentivement cette notice de montage,
Car nous déclinons toute responsabilité en cas d'erreurs
Découlant d'un montage erroné !

I – prego leggere attentamente le istruzioni per il montaggio,
Poiché decliniamo qualsiasi responsabilità
Per difetti derivanti da montaggio errato.

S - läs monteringsanvisningarna noggrant.
Vi avsäger oss allt ansvar för defekter som
Uppstår p.g.a. Felaktig montering.

Hr – pažljivo pročitajte upute za montažu,
Jer otklanjamo svaku odgovornost za pogreške
Nastale uslijed pogrešne montaže.

Slo – prosimo, da pozorno preberete navodila za montažo,
Saj zavračamo vsakršno odgovornost za napake,
Ki bi nastale zaradi napačne montaže.

Nl – leest u alstublieft deze montagehandleiding goed door,
Voor fouten door verkeerde montage zijn wij niet verantwoordelijk.

Pl – prosze uwaznie zapoznac sie z instrukcja montazu,
Poniewaz nie ponosimy odpowiedzialnosci za niewlasciwy montaz.

HU – Kérjük, olvassa el figyelmesen
ezt az összeszerelési útmutatót,
mert a helytelen összeszerelésből
a dódó hibákért nem vállalunk felelősséget!

SK – Prosíme, dobre prečítajte si tento návod na montáž,
pretože nepreberáme žiadne ručenie za chyby,
ktoré vzniknú na základe chybnej montáže!

RO – Vă rugăm să cititi cu atenție aceste instructiuni
de montaj deoarece nu preluăm garanția pentru defecte
ce apar datorită unui montaj incorect!

RUS – Пожалуйста, внимательно ознакомьтесь ù
с данной инструкцией по монтажу, поскольку мы не
несем ответственности за ошибки, причиной которых
является неправильный монтаж.

TU – İlkonce kullanma klavuzunu iyi okkuyun,
yalnis montaj yapasaniz bunun sorumlusu biz degiliz.

ES – Se ruega leer con atención las instrucciones
de montaje debido a que declinamos cualquier
responsabilidad
por defectos derivados de un montaje erróneo.

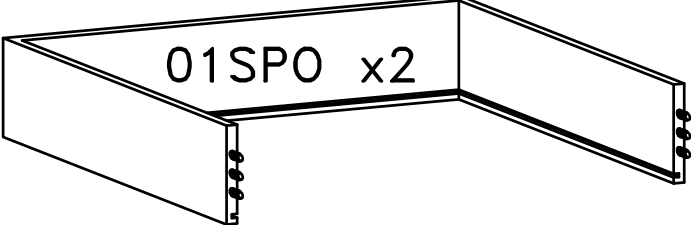
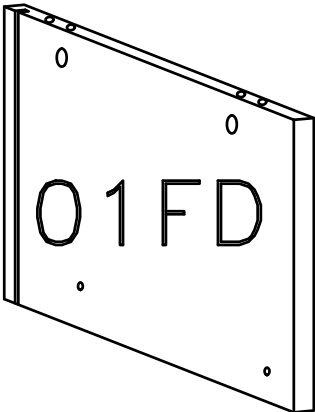
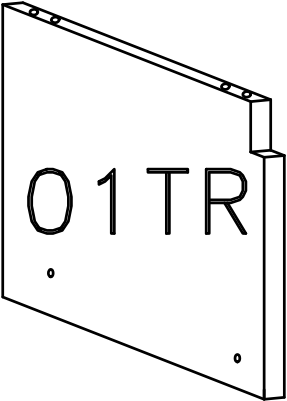
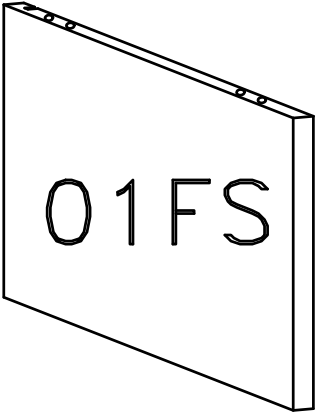
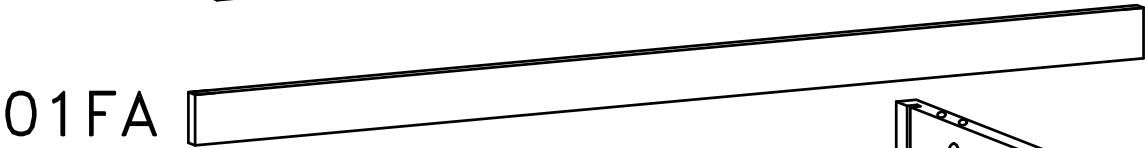
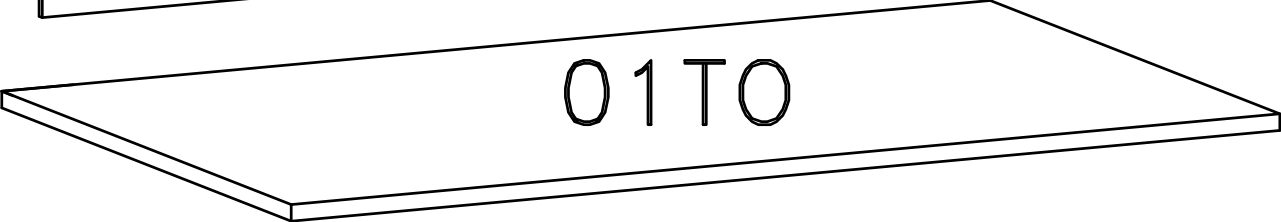

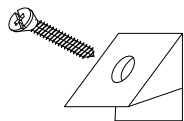
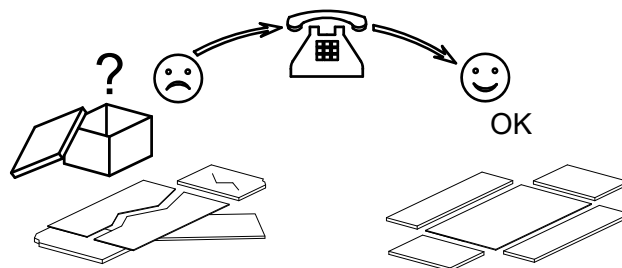
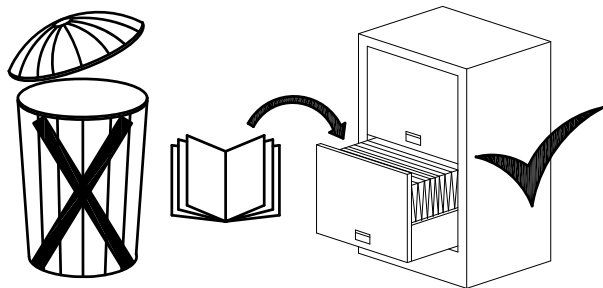

F x12

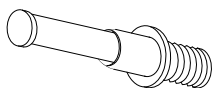

D x6



P x4

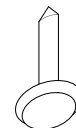

CH x6

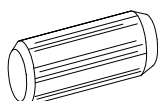

8x30 mm.

B x12



F3 x6

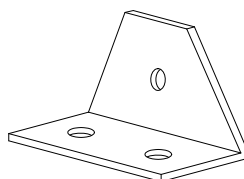

P7 x3

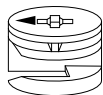

∅15 x 12 mm

C x6

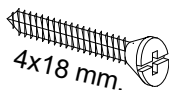

4x18 mm.

L418 x9



6x9mm.

E9 x8

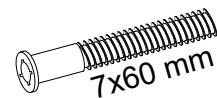

7x60 mm.

E x6

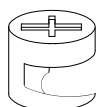

∅12 mm.

C1 x8



D1 x8



3.5x16 mm.

L3516 x8

CL

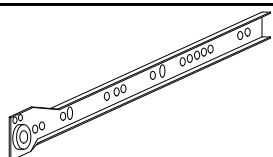

DR

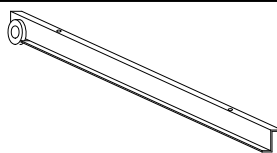

x2

x2

CR

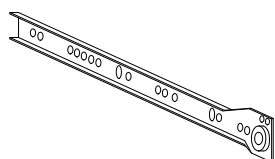

DL

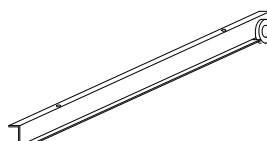

x2

x2

N3AST

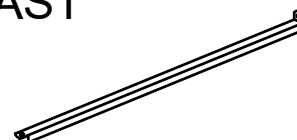

x2

1



8x30 mm.

B x12

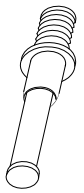

D x6

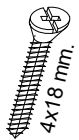

4x18 mm.

L418 x6

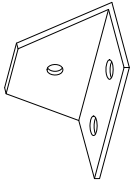

P7 x3

CL

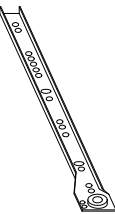

x2

E9

x8



6x9mm.

CR

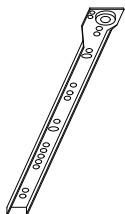

x2

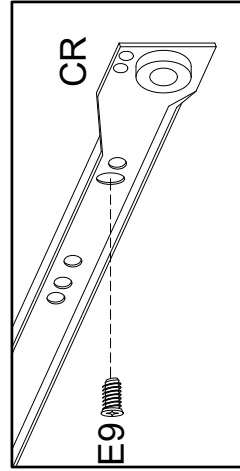
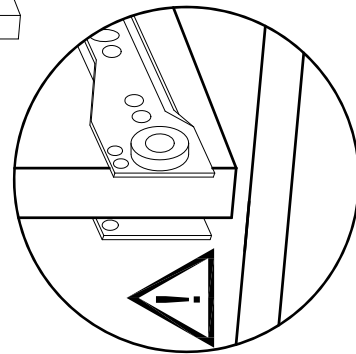
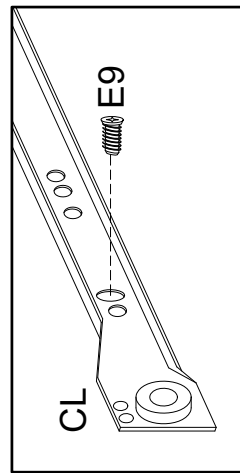
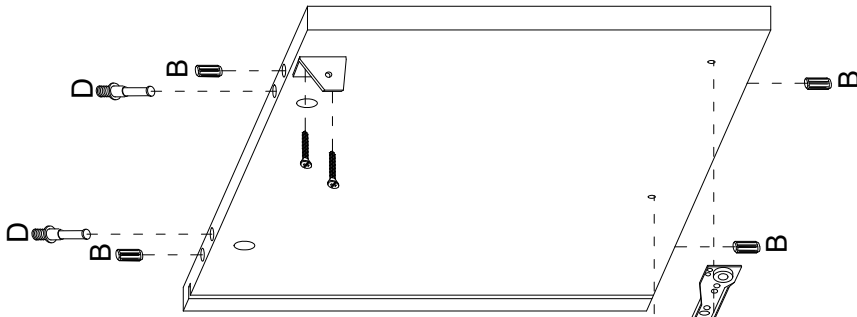
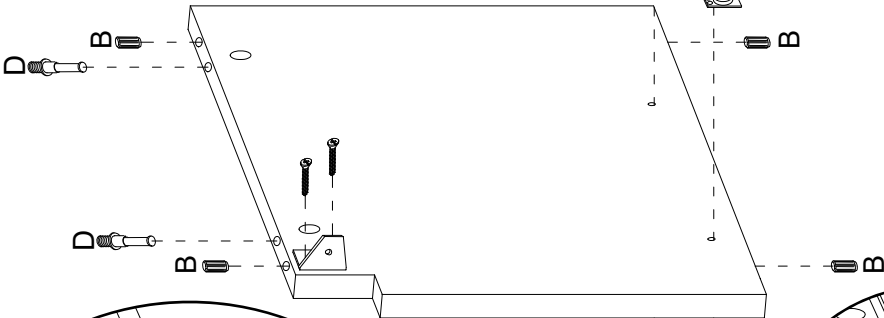
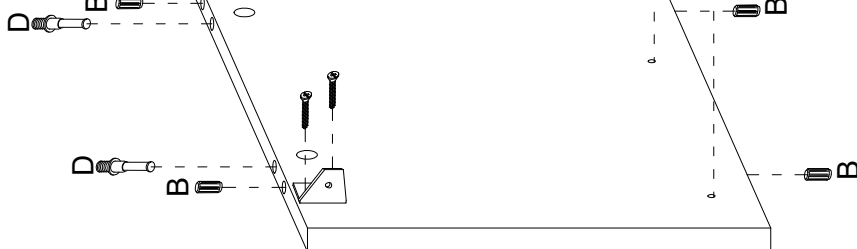
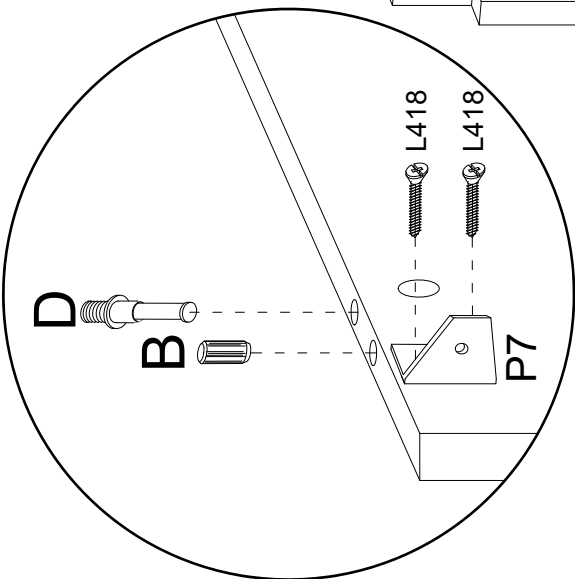

2

CH

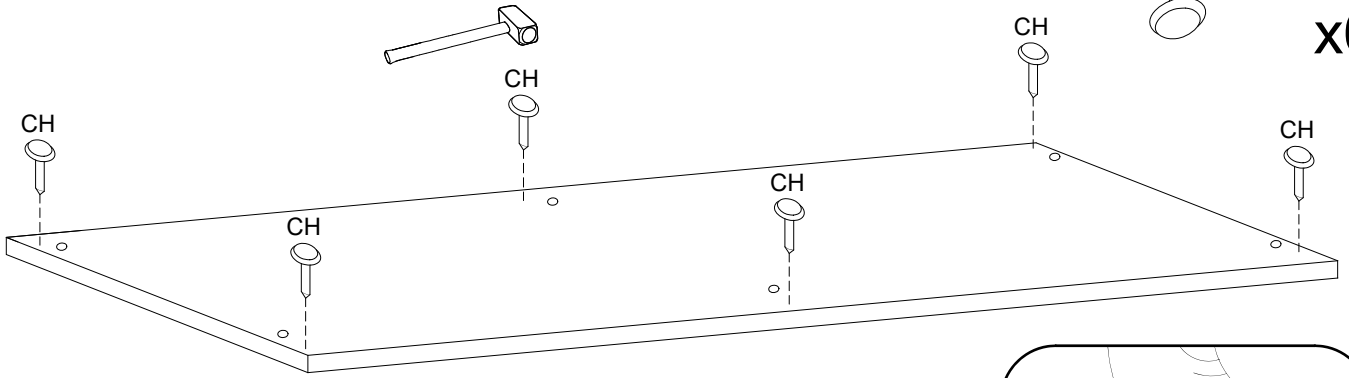

x6

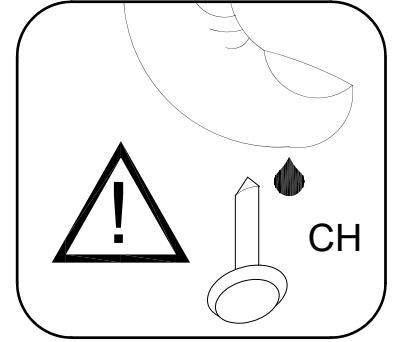

E

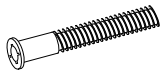

7x60 mm.

x6

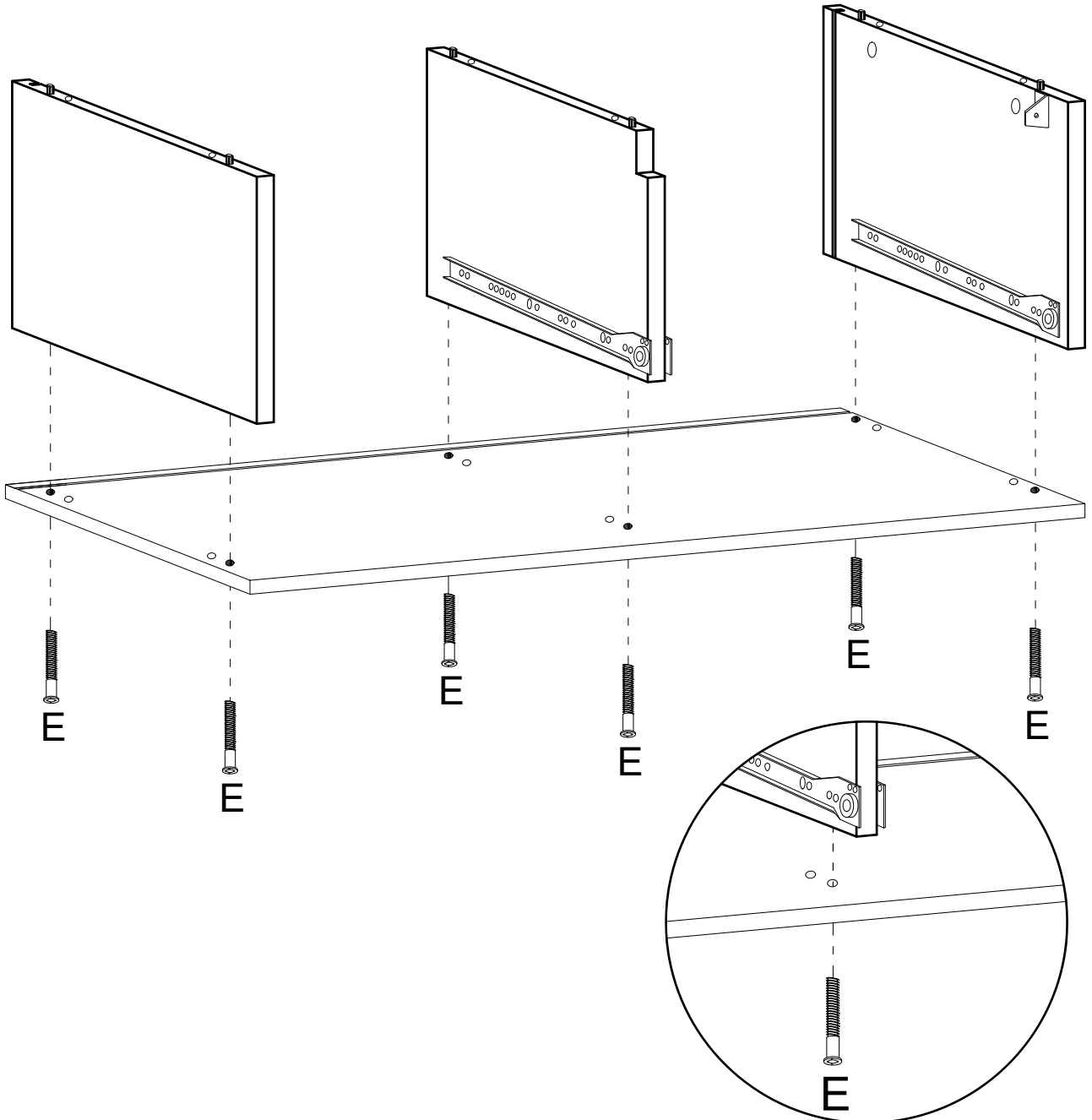

3

L418

4x18 mm. x3

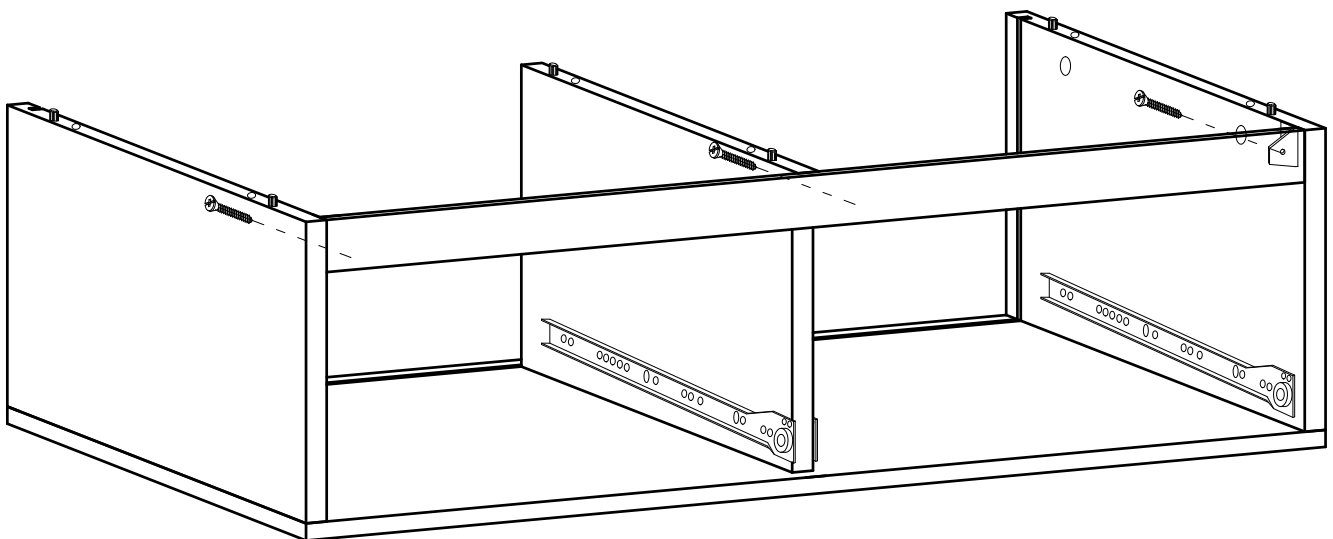
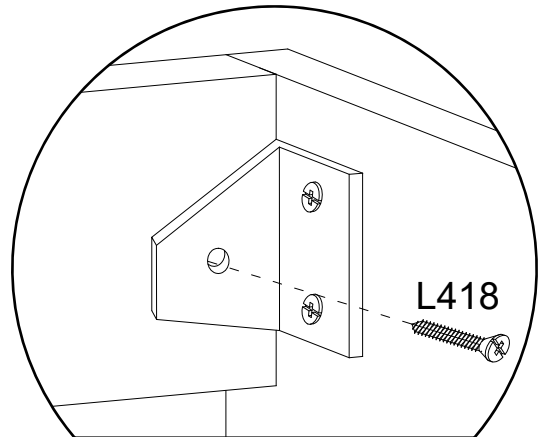
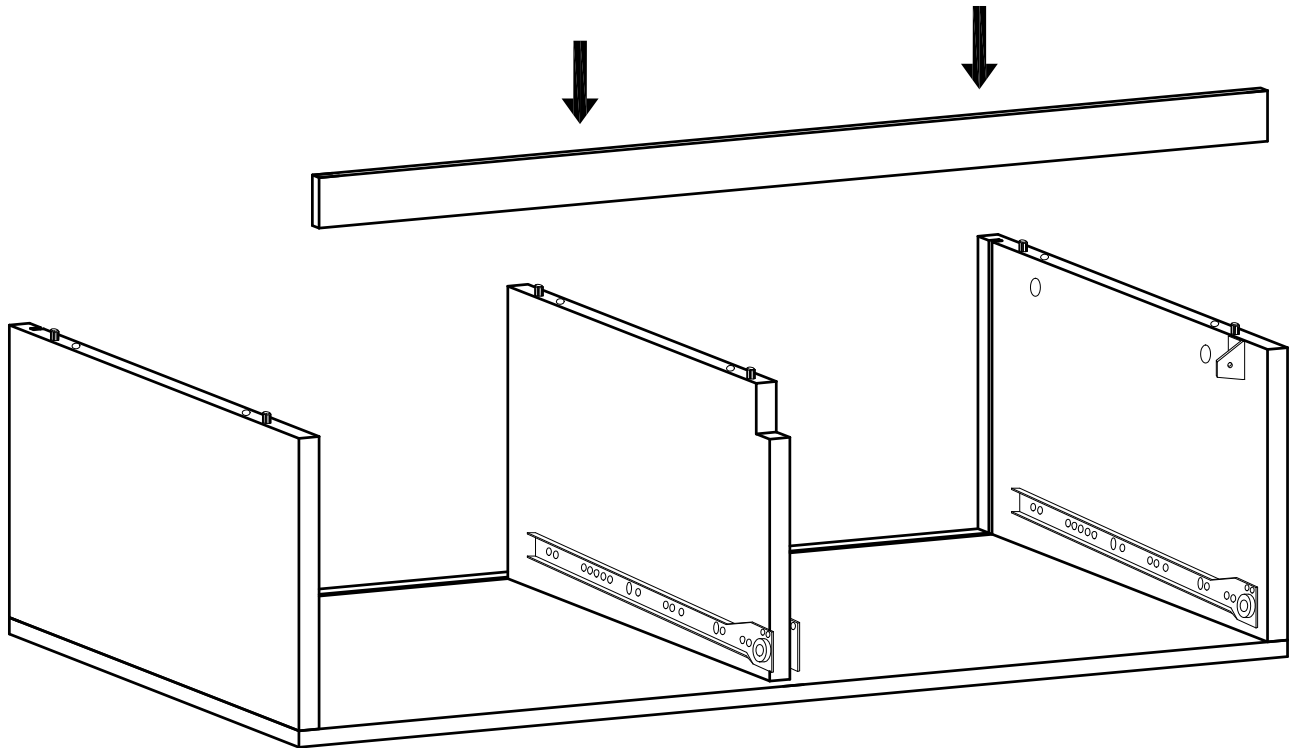
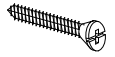

4

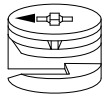

∅15 x 12 mm

C x6

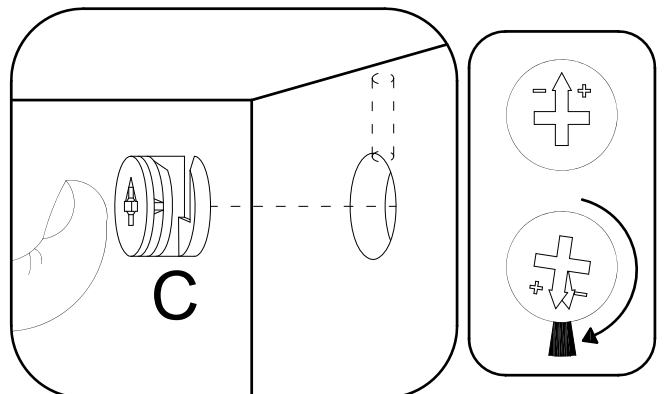
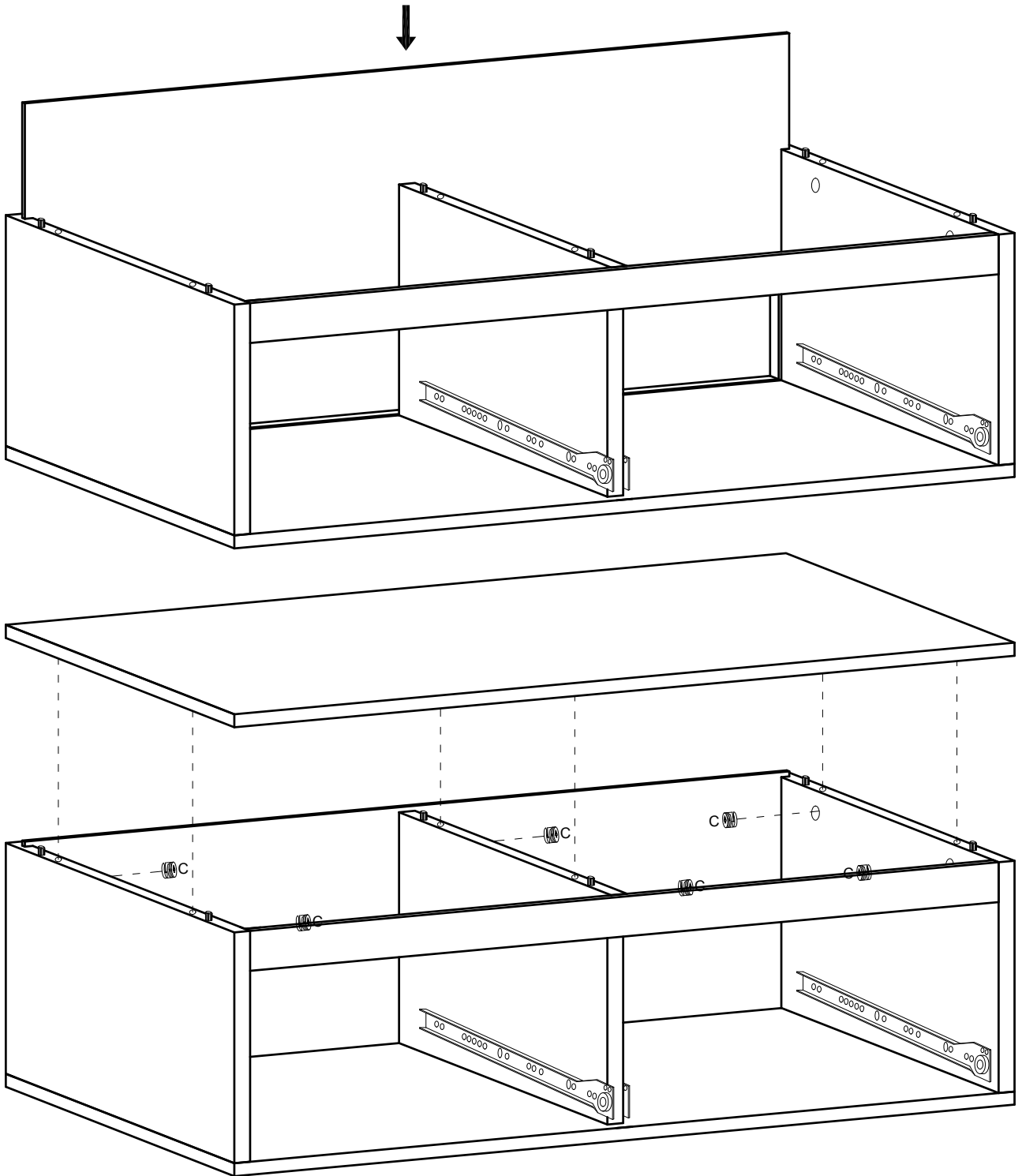

5

F

x8

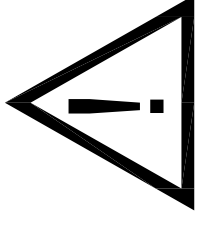
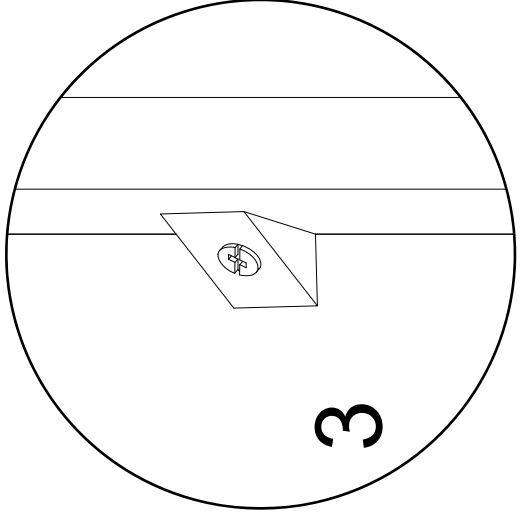
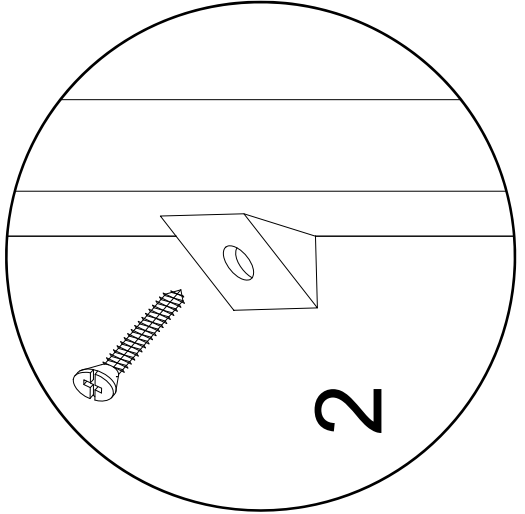
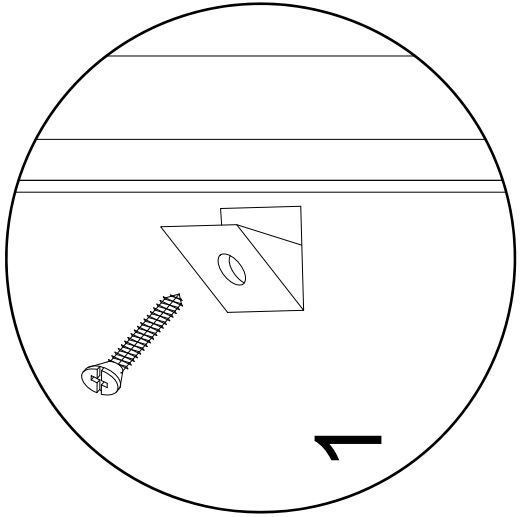
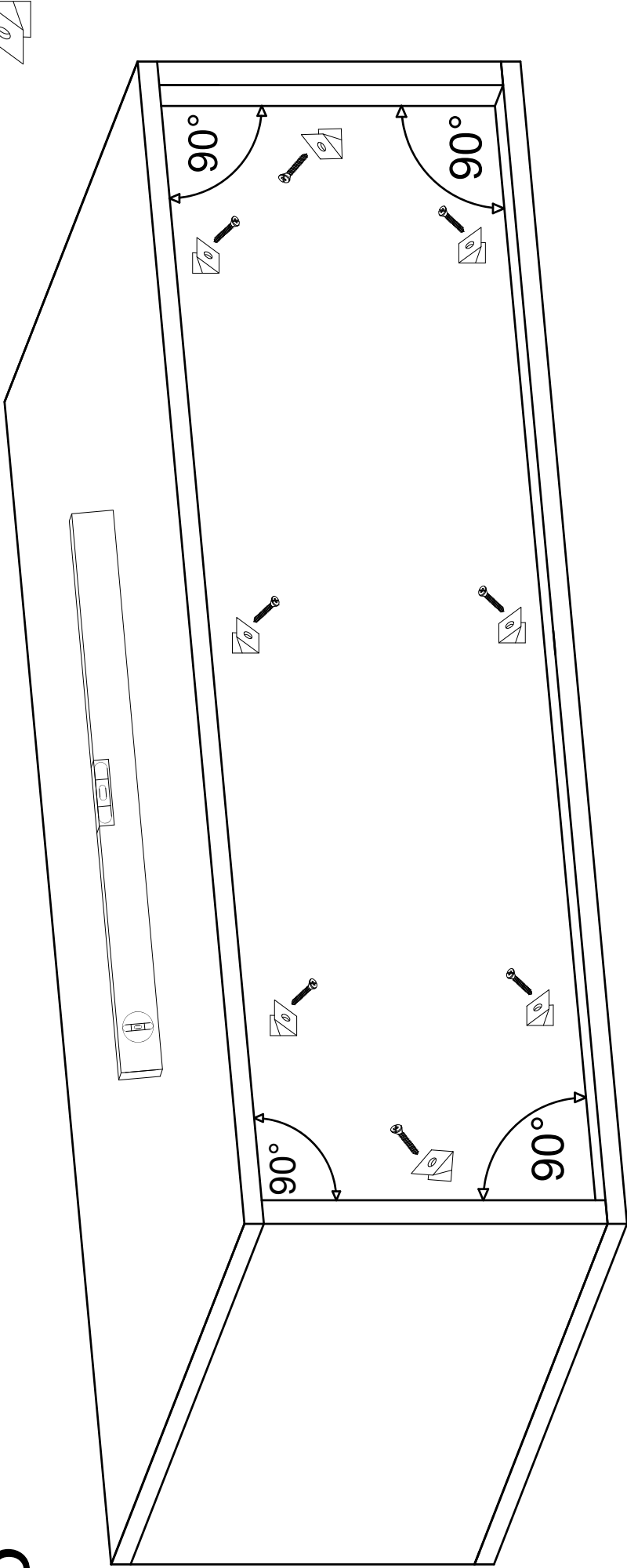

6

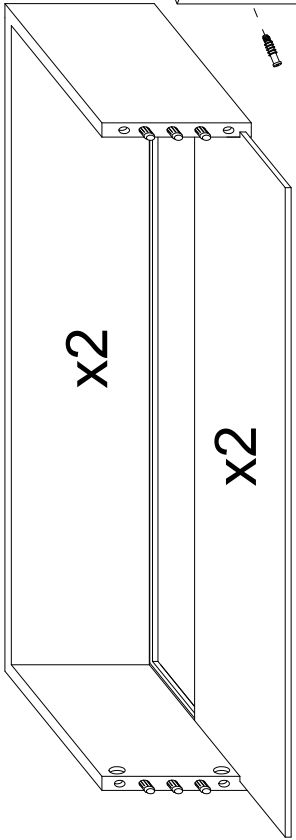

C1

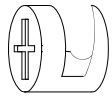

ø12 mm.

x8

D1

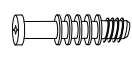

x8

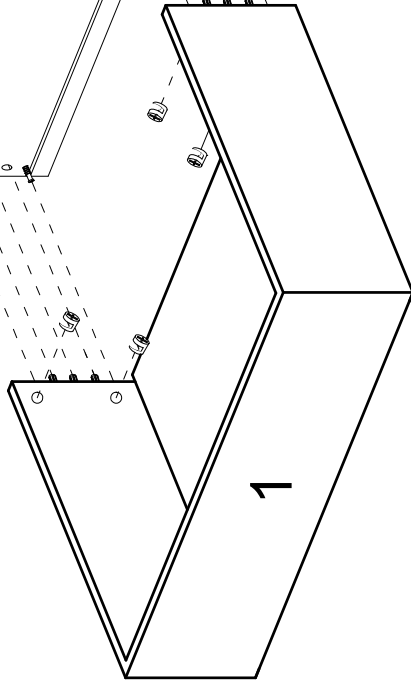
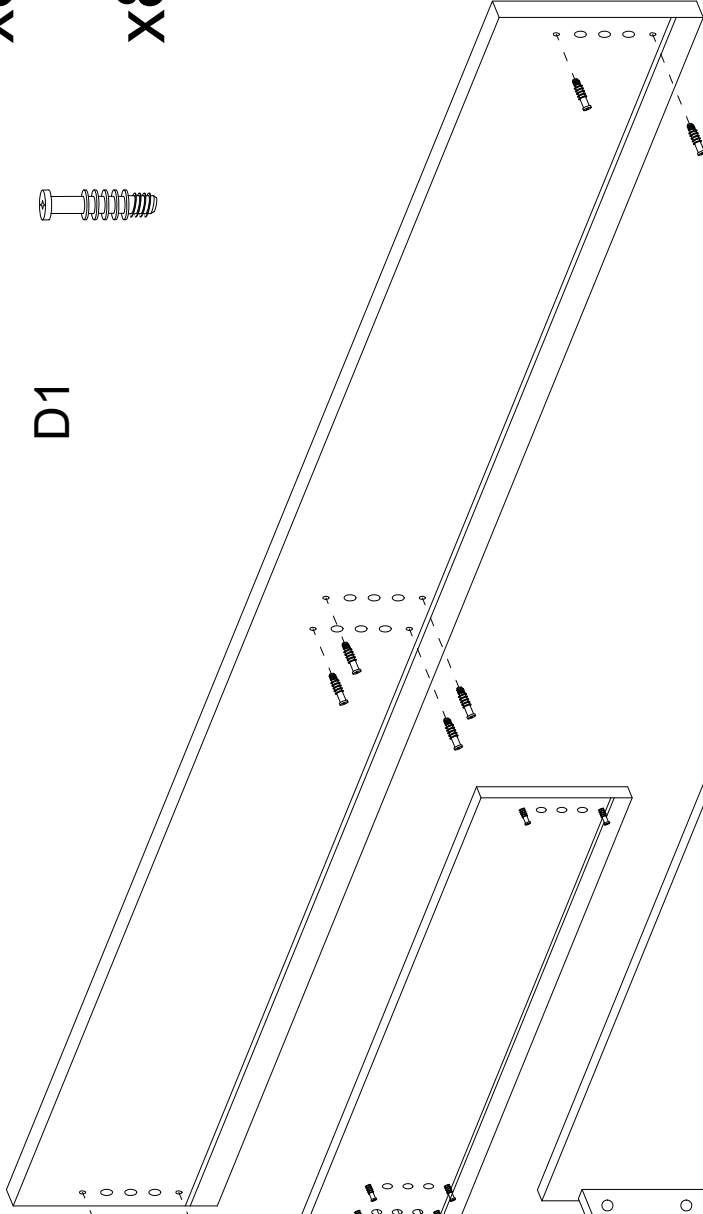

1

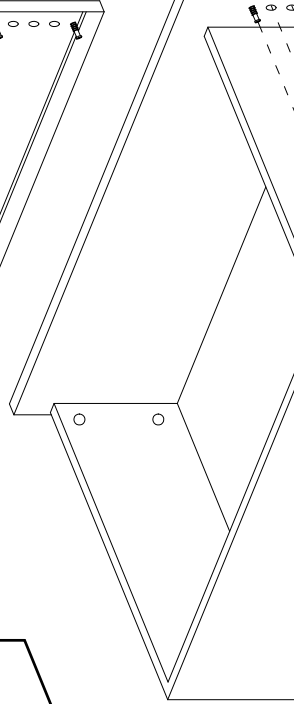

2

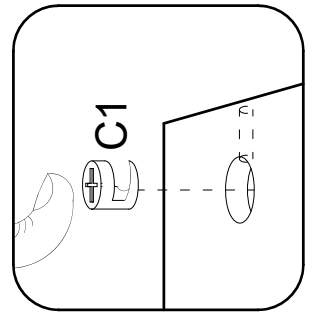

C1

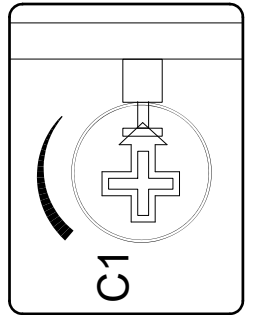

C1

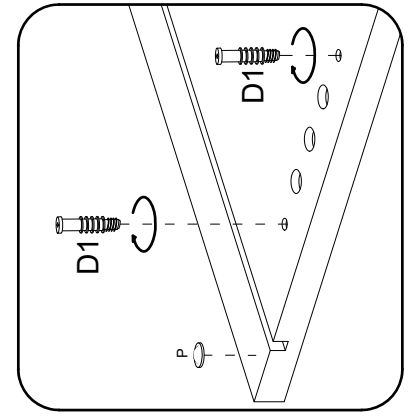
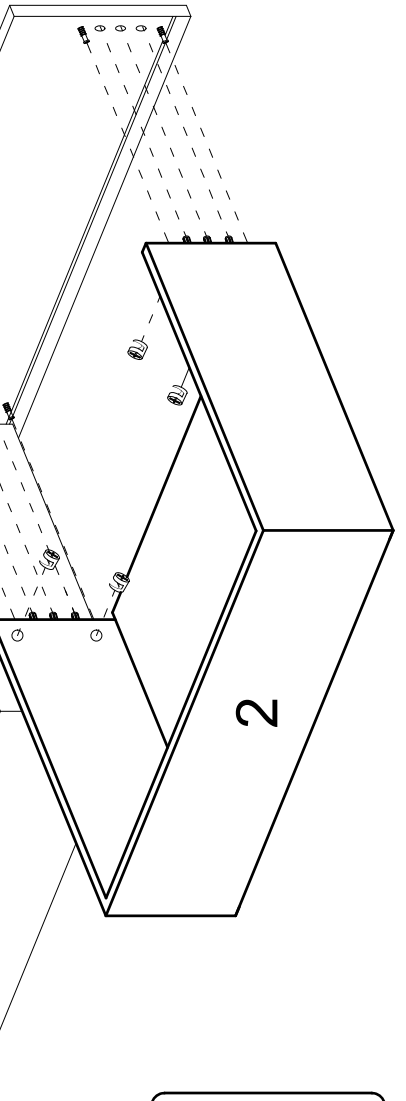

D1

D1

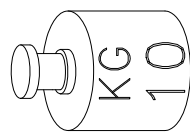
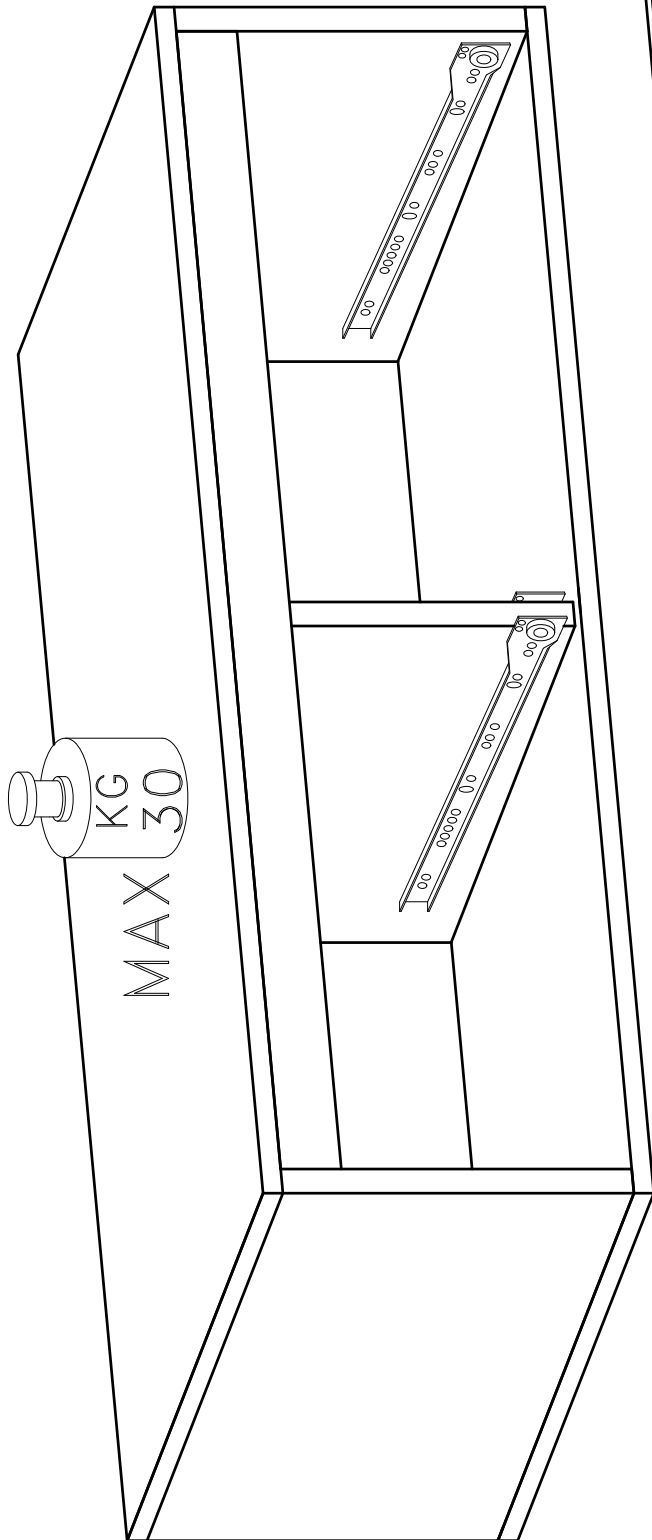

MAX

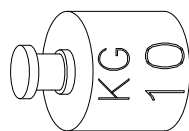

MAX

Montageanweisung / Installation instructions / Instruction de montage / Istruzioni di montaggio
montagehandleiding / Instrukcja montazu / Montaj talimatlar / Osszeszerelési útmutatót / Nàvod k montázi /
Nàvod na montaz / Instructiune de montaj / Инструкция по монтажу / Montaj talimatina / Monteringsanvisningar
Upute za montažu / Instrucciones de Montaje / Navodila za montažo

INFINITY 2.0

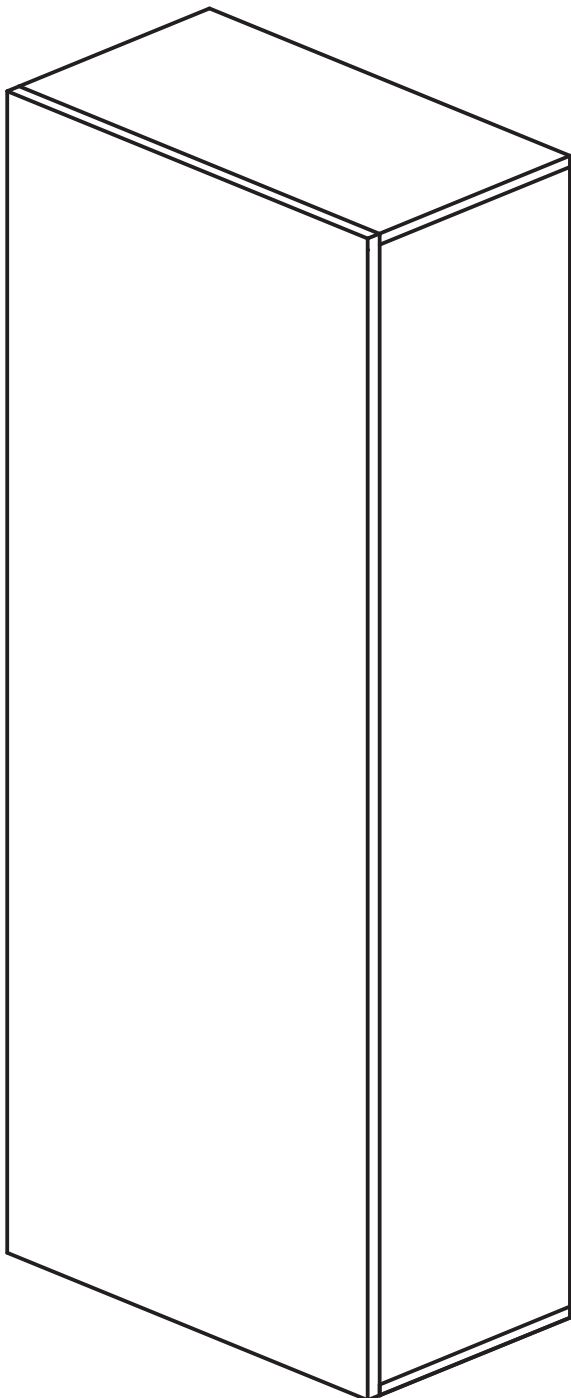
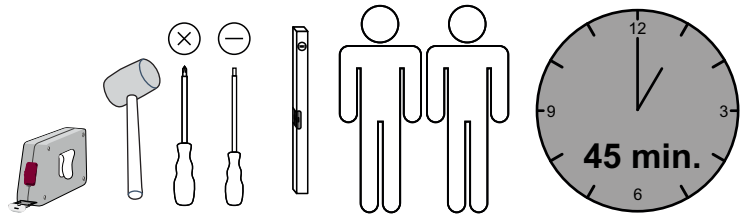

D – bitte lesen sie diese montageanleitung gut durch,
Da wir für fehler, die durch falsche montage entstehen,
Keine haftung übernehmen!

Gb – please read these installation instructions
Through carefully as we cannot accept any liability
For faults occurring as a result of incorrect installation!

Cz – přečtěte si prosím pozorně tento návod k montáži,
Aby jste předešli chybám vzniklých špatnou montáží,
Za které neručíme!

F – veuillez lire attentivement cette notice de montage,
Car nous déclinons toute responsabilité en cas d'erreurs
Découlant d'un montage erroné !

I – prego leggere attentamente le istruzioni per il montaggio,
Poiché decliniamo qualsiasi responsabilità
Per difetti derivanti da montaggio errato.

S - läs monteringsanvisningarna noggrant.
Vi avsåger oss allt ansvar för defekter som
Uppstår p.g.a. Felaktig montering.

Hr – pažljivo pročitajte upute za montažu,
Jer otklanjamo svaku odgovornost za pogreške
Nastale uslijed pogrešne montaže.

Slo – prosimo, da pozorno preberete navodila za montažo,
Saj zavračamo vsakršno odgovornost za napake,
Ki bi nastale zaradi napačne montaže.

Nl – leest u alstublieft deze montagehandleiding goed door,
Voor fouten door verkeerde montage zijn wij niet verantwoordelijk.

Pl – prosze uwaznie zapoznac sie z instrukcja montazu,
Poniewaz nie ponosimy odpowiedzialnosci za niewlasciwy montaz.

HU – Kérjük, olvassa el figyelmesen
ezt az összeszerelési útmutatót,
mert a helytelen összeszerelésből
a dódó hibákért nem vállalunk felelősséget!

SK – Prosime, dobre prečítajte si tento návod na montáž,
pretože nepreberáme žiadne ručenie za chyby,
ktoré vzniknú na základe chybnej montáže!

RO – Vă rugăm să cititi cu atenție aceste instructiuni
de montaj deoarece nu preluăm garanția pentru defecte
ce apar datorită unui montaj incorect!

RUS – Пожалуйста, внимательно ознакомьтесь ù
с данной инструкцией по монтажу, поскольку мы не
несем ответственности за ошибки, причиной которых
является неправильный монтаж.

TU – İlkonce kullanma klavuzunu iyi okuyun,
yalnis montaj yapasaniz bunun sorumlusu biz degiliz.

ES – Se ruega leer con atención las instrucciones
de montaje debido a que declinamos cualquier
responsabilidad
por defectos derivados de un montaje erróneo.

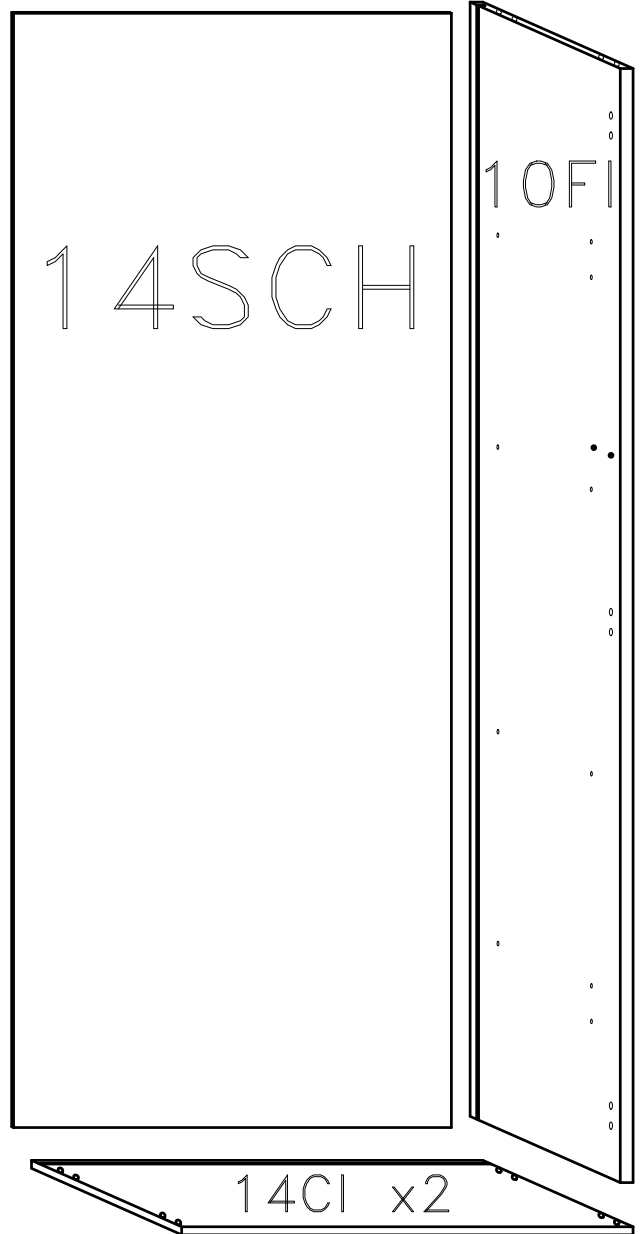
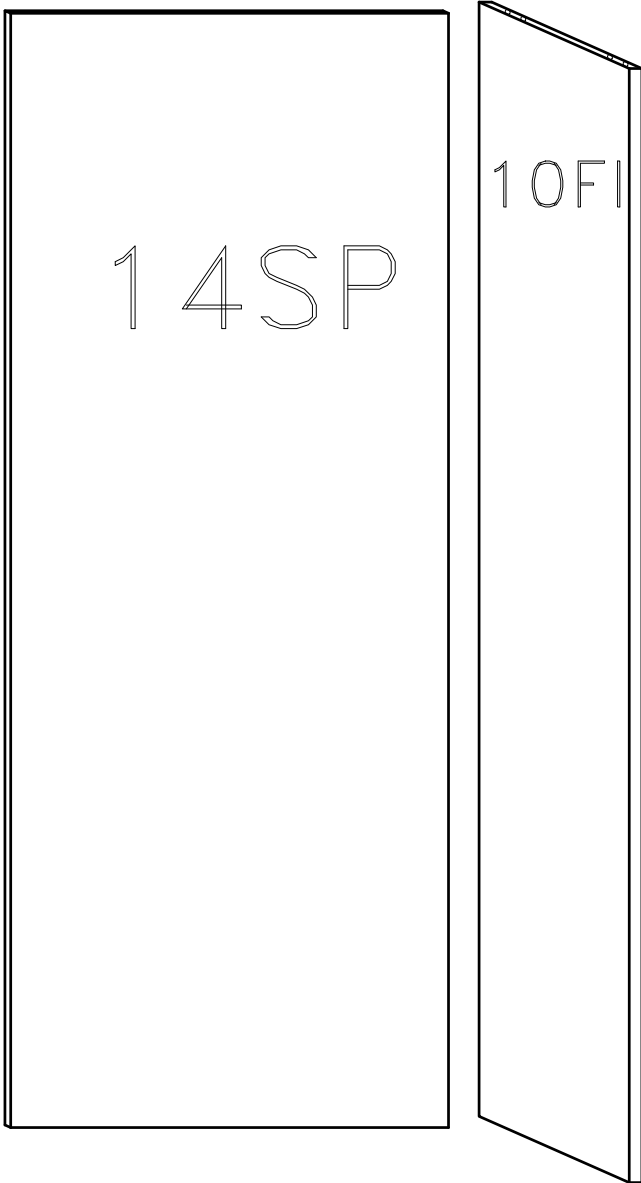
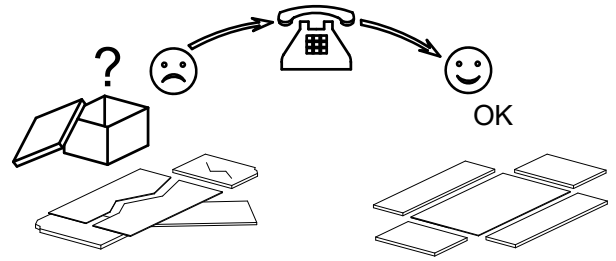
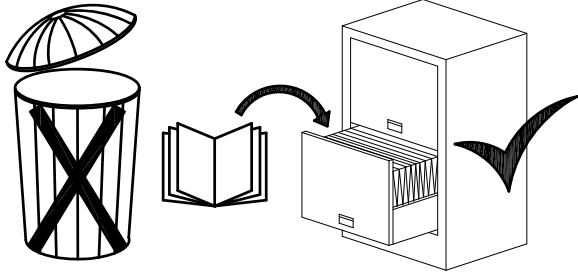

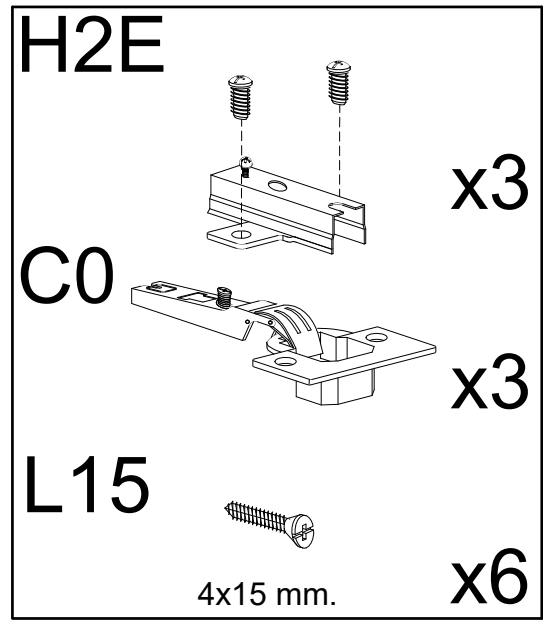
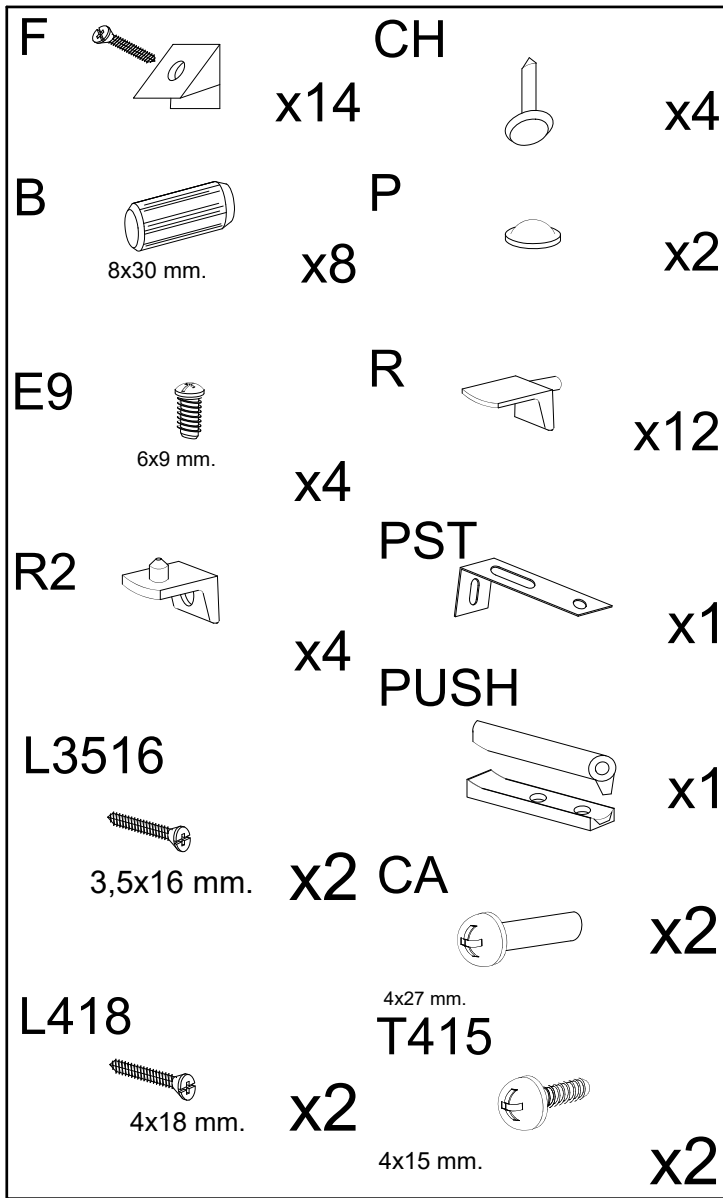

1

CH

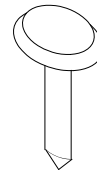



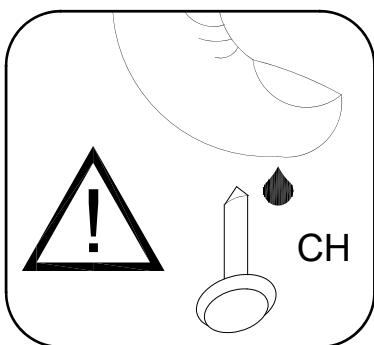
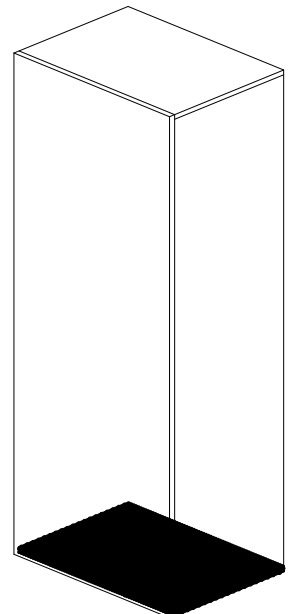

x4

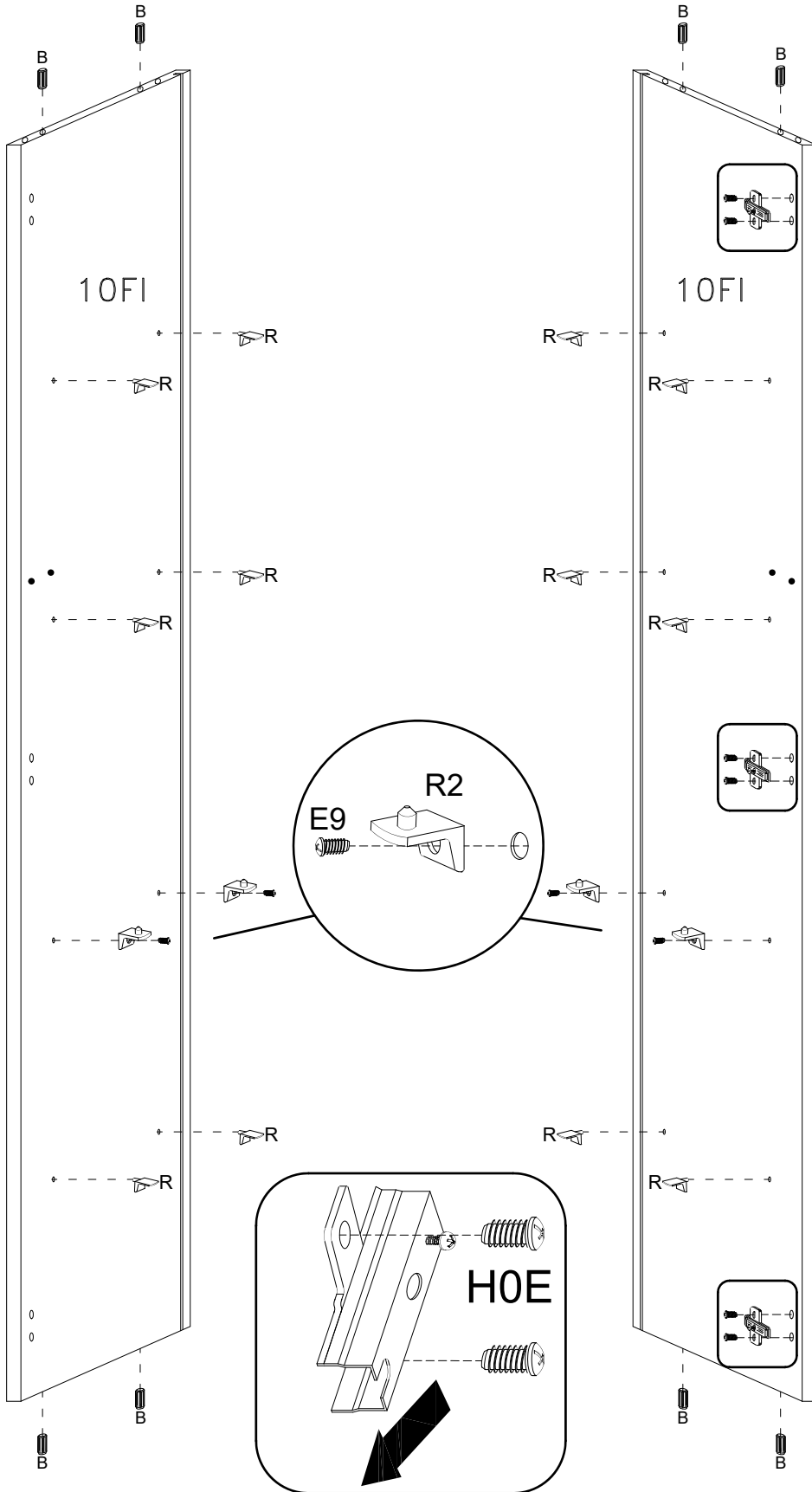

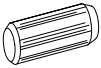
2

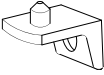

- B**  8x30 mm. **x8**
- H0E**  **x3**
- E9**  6x9 mm. **x4**
- R2**  **x4**
- R**  **x12**

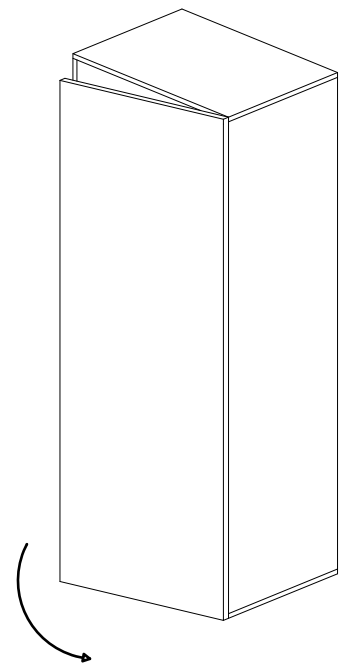

3

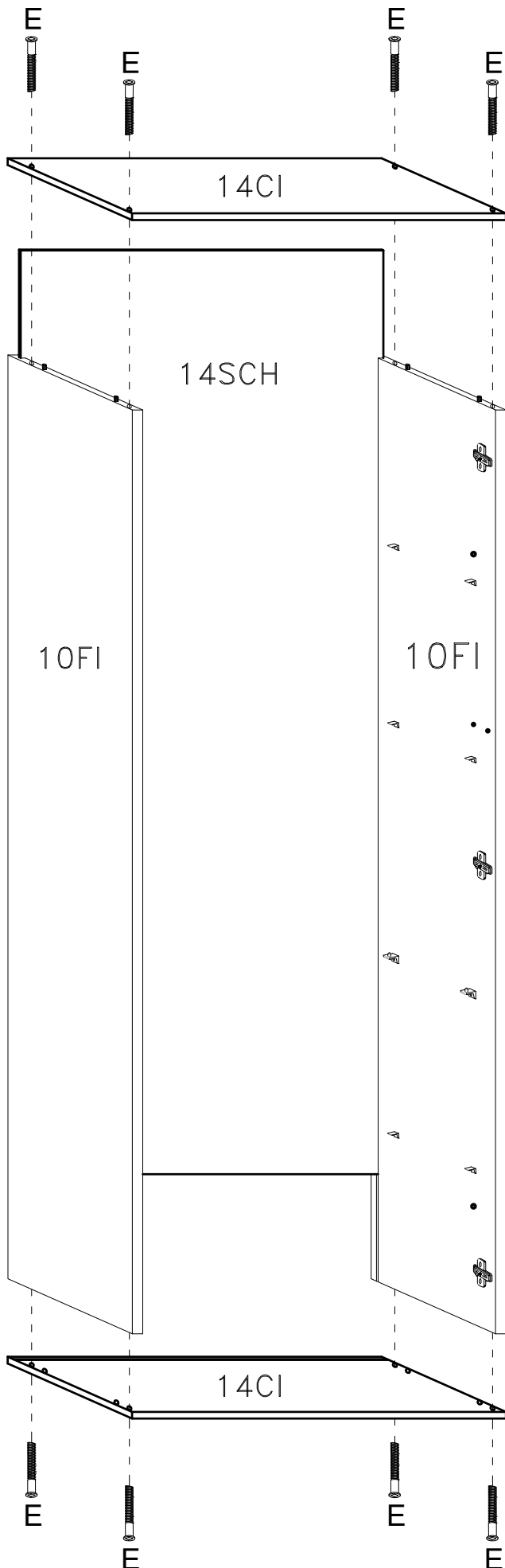

E

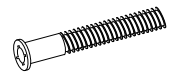

7x60 mm.

x8

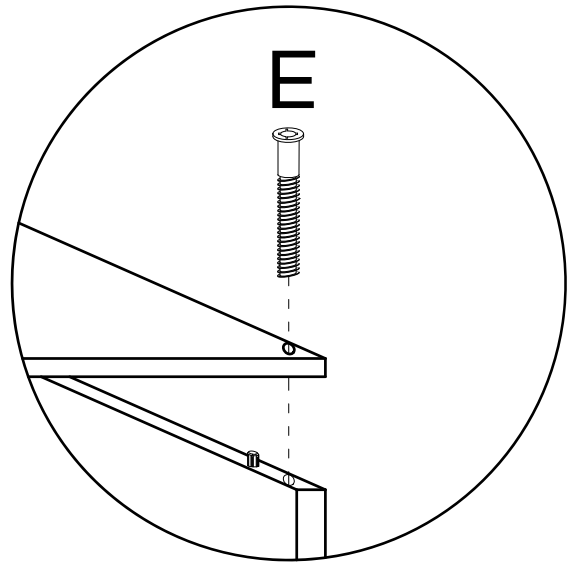

4

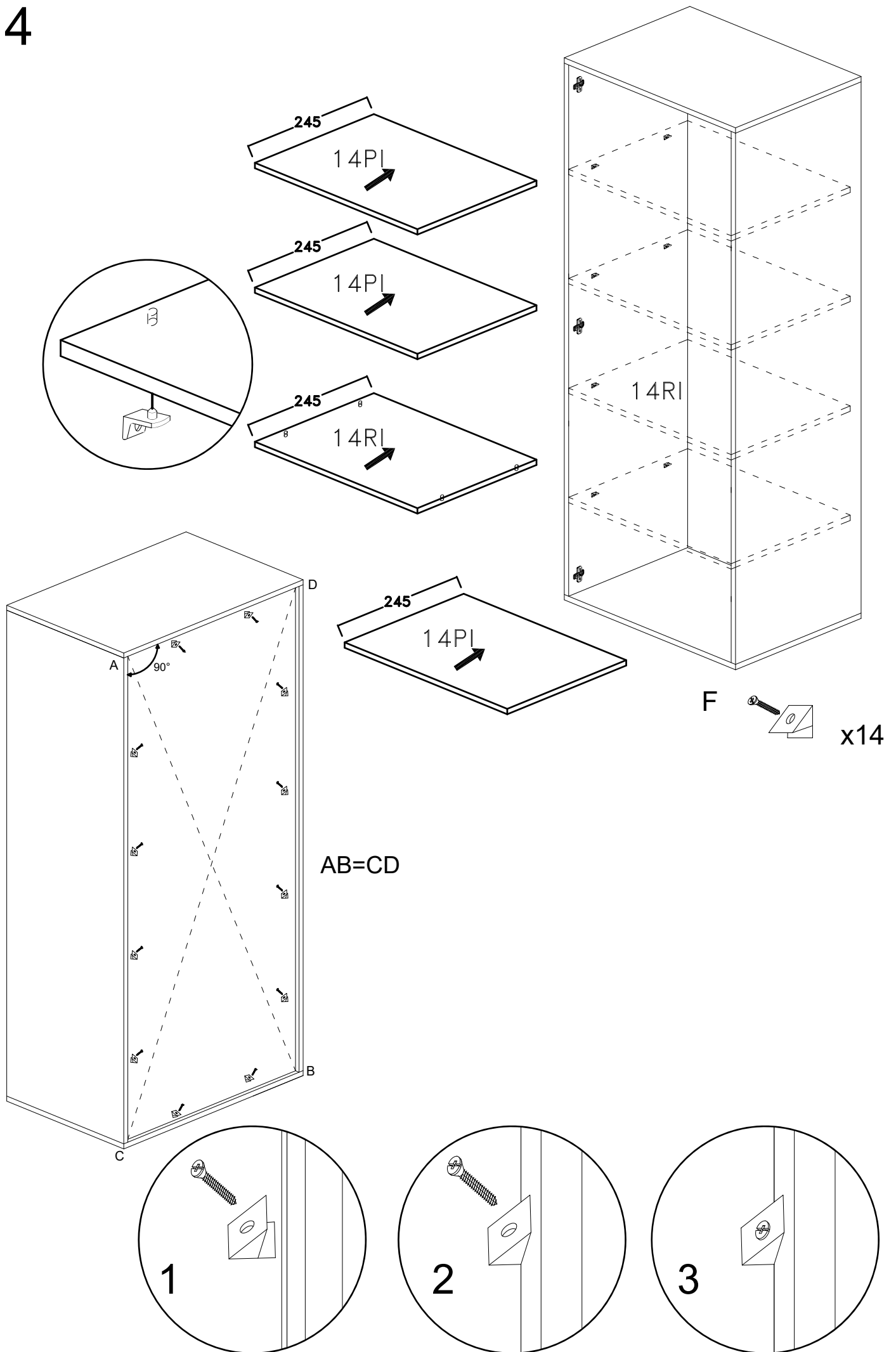

5

- C0 X3
- L15 X6
- 4x15 mm. P X2

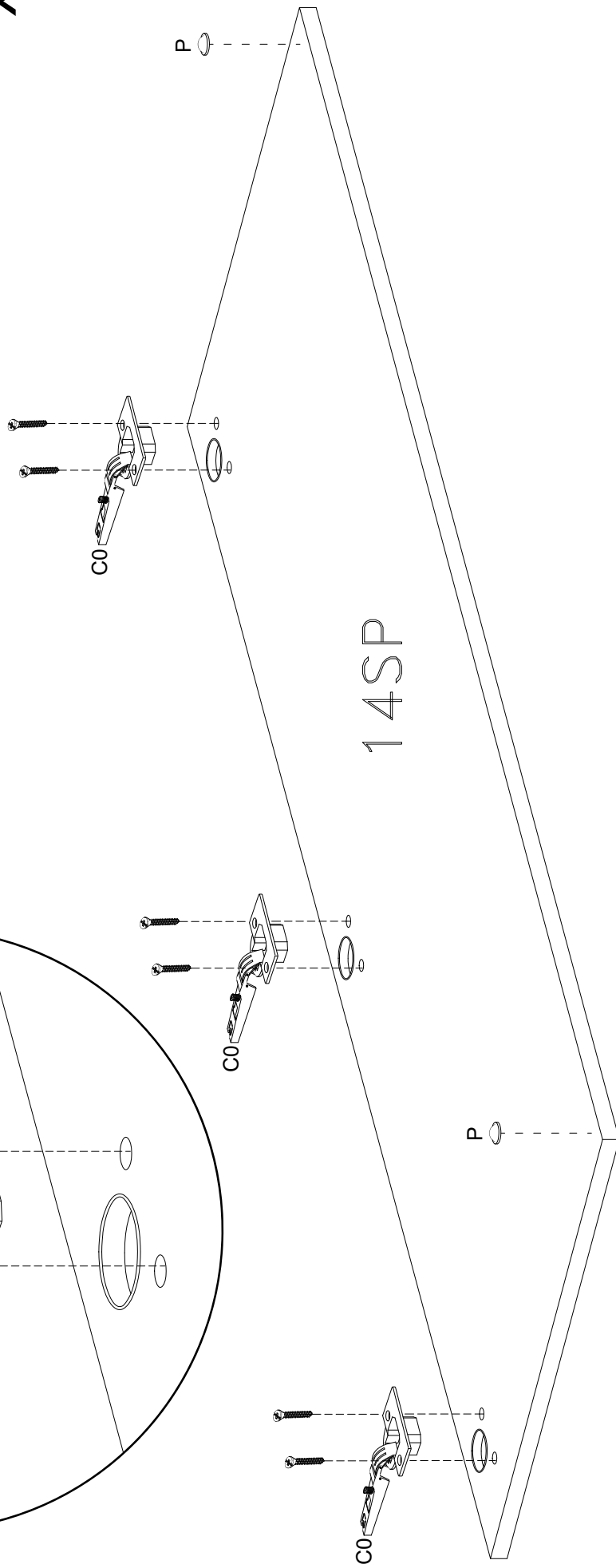
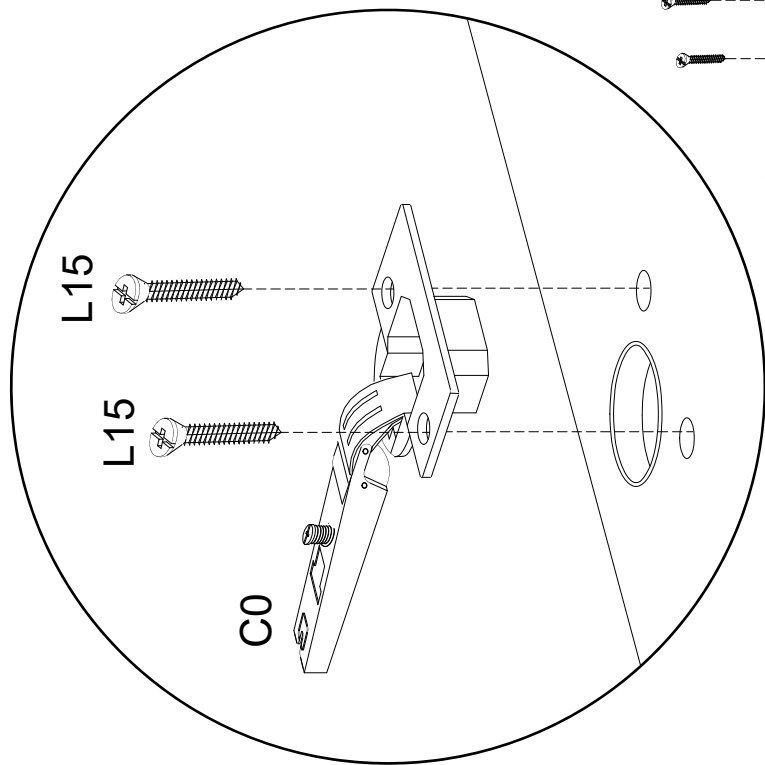

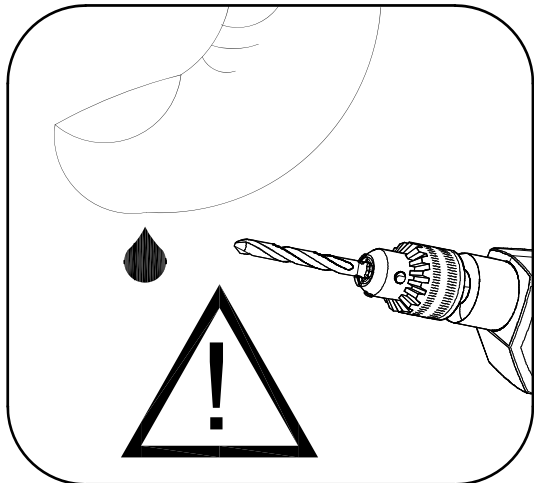
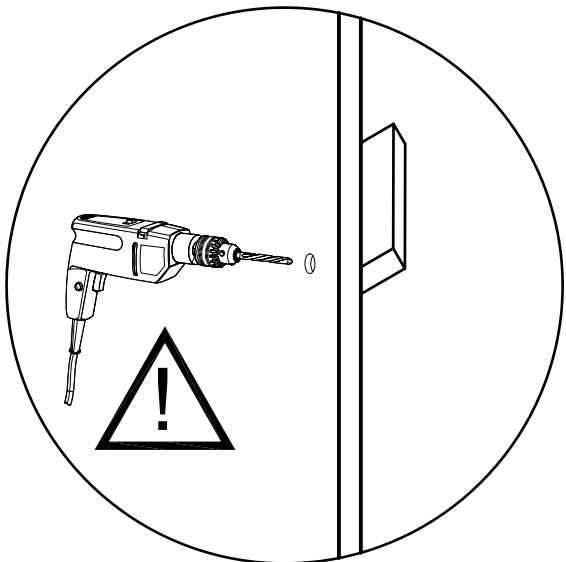
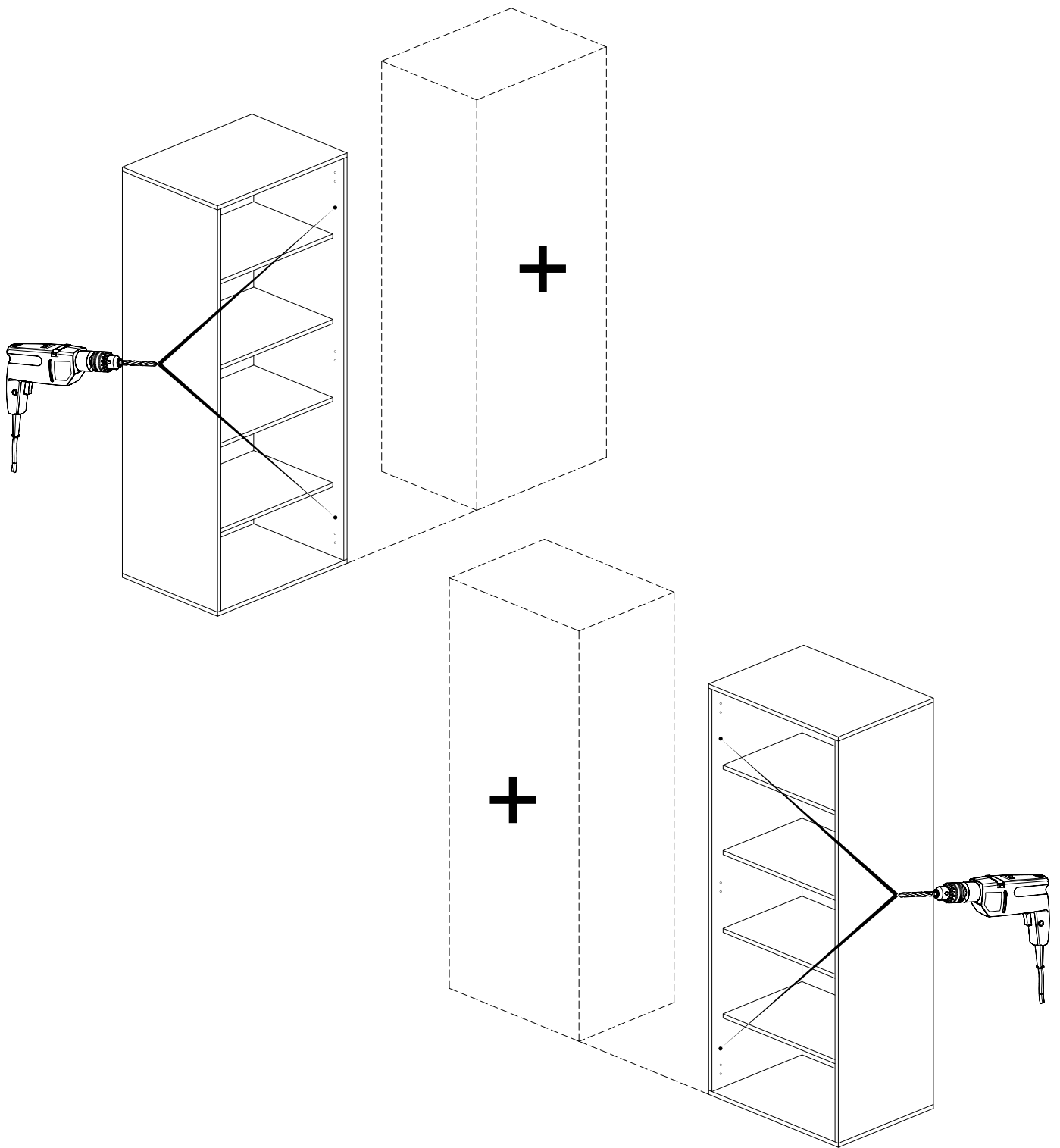

CA

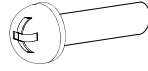

4x27 mm.

T415

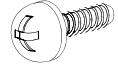

4x15 mm.

x2

x2

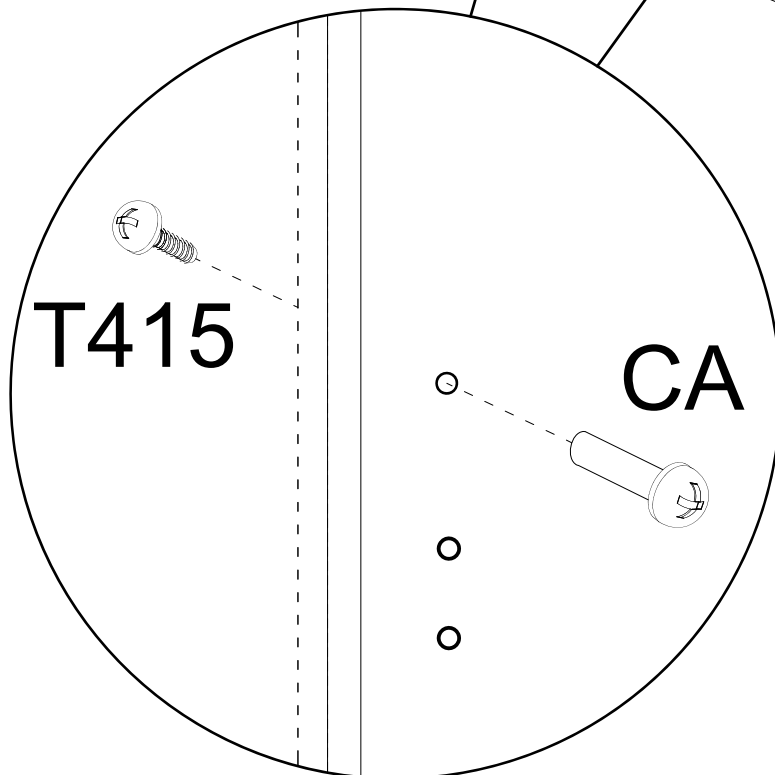
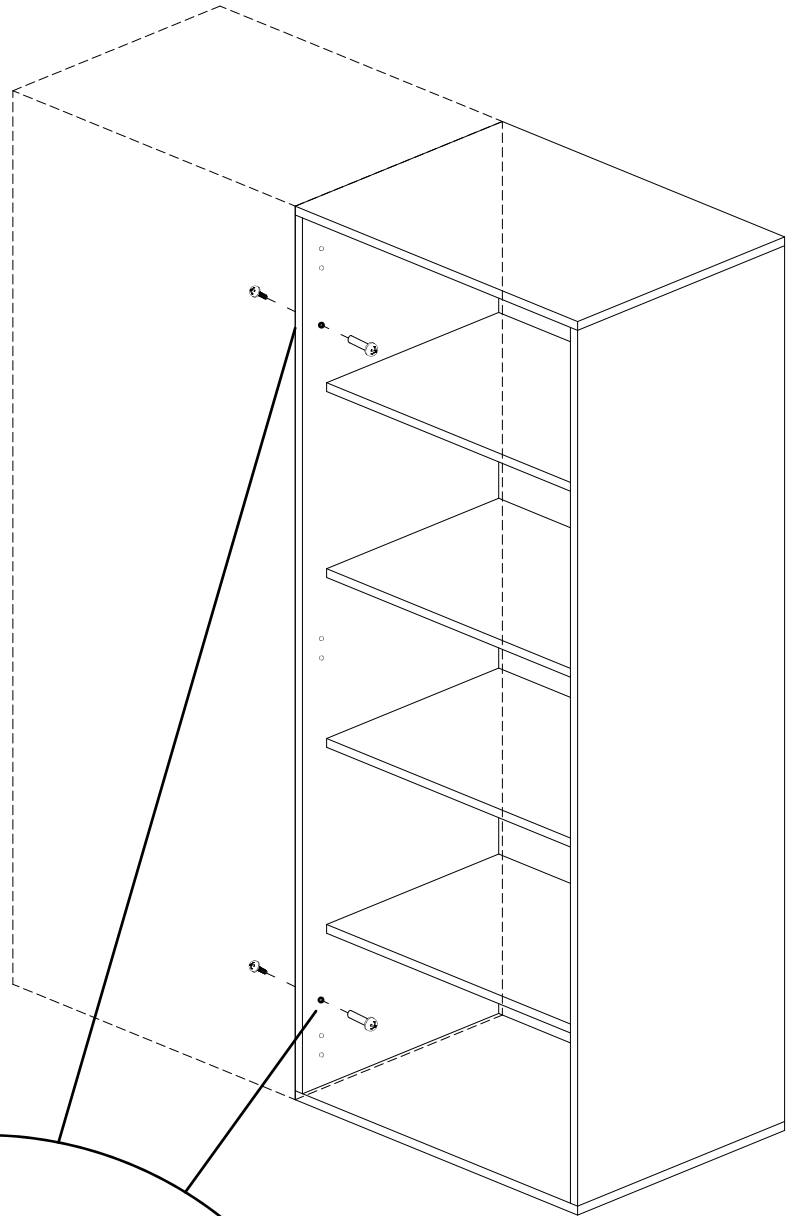

PUSH

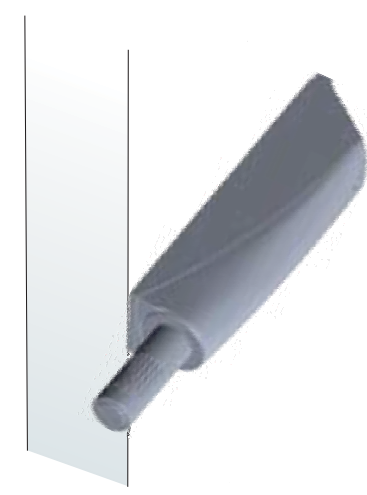
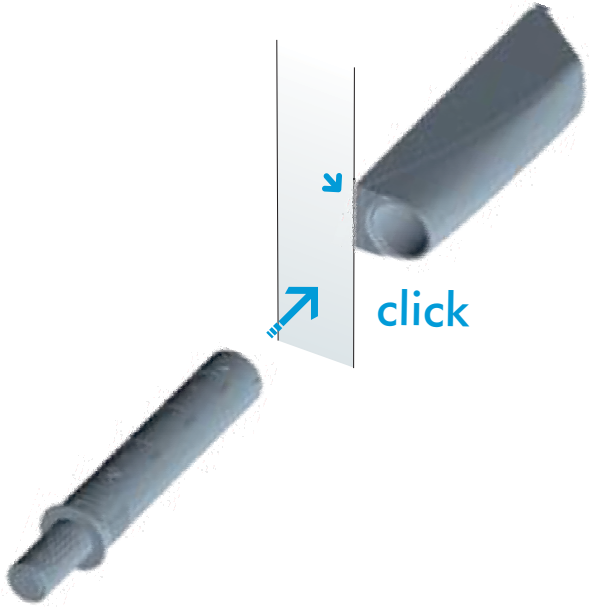
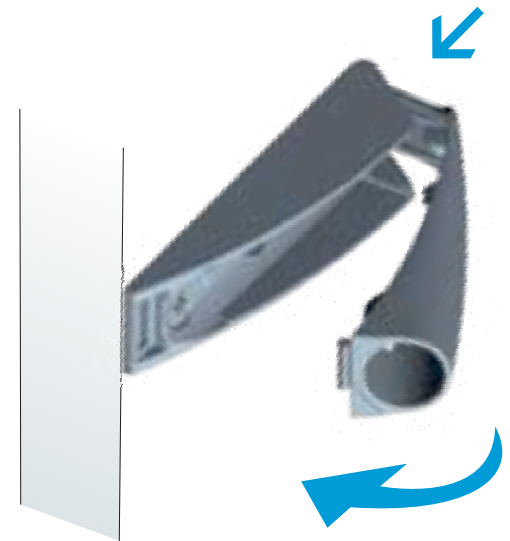
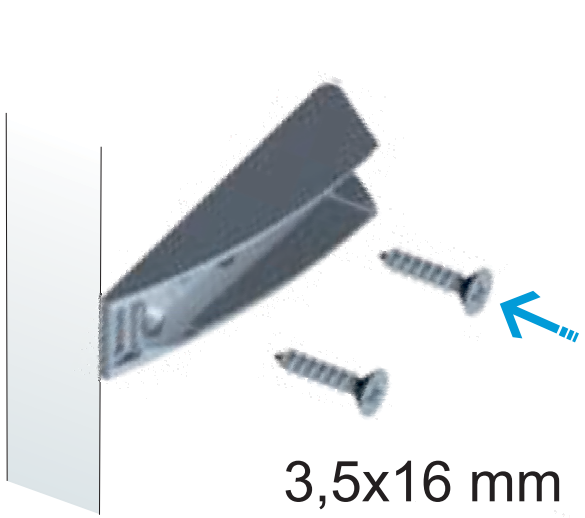
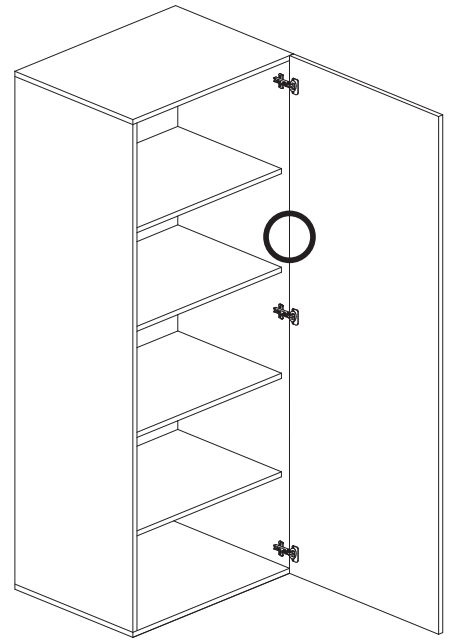
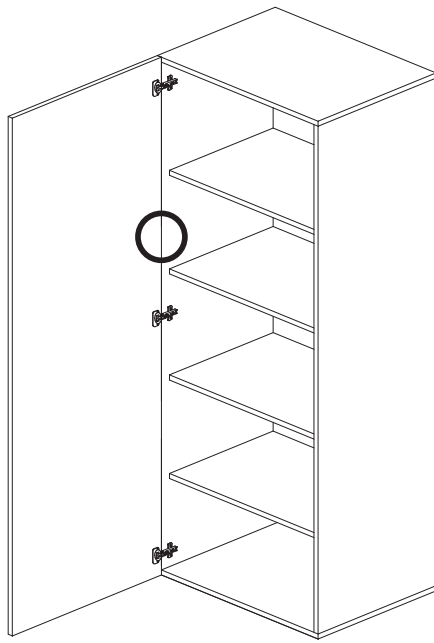

CORSA DI SGANCIO E REGOLAZIONE

Minima regolazione

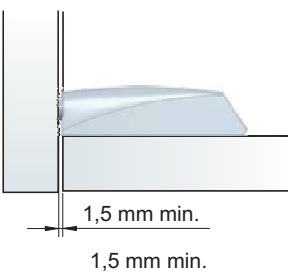

Massima regolazione

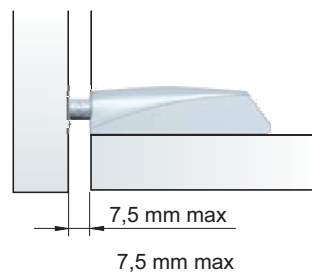

Corsa regolazione

0+6 mm

0+6 mm



0+6 mm



Regolando fino a fine corsa, non esce

6

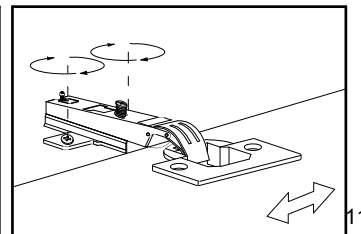
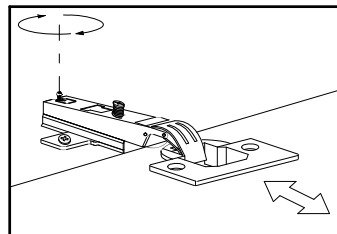
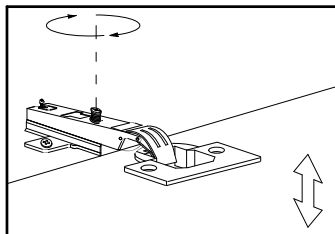
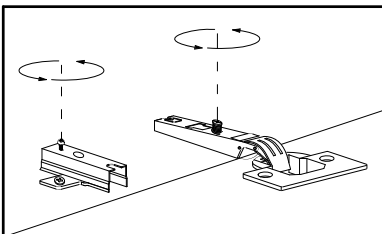
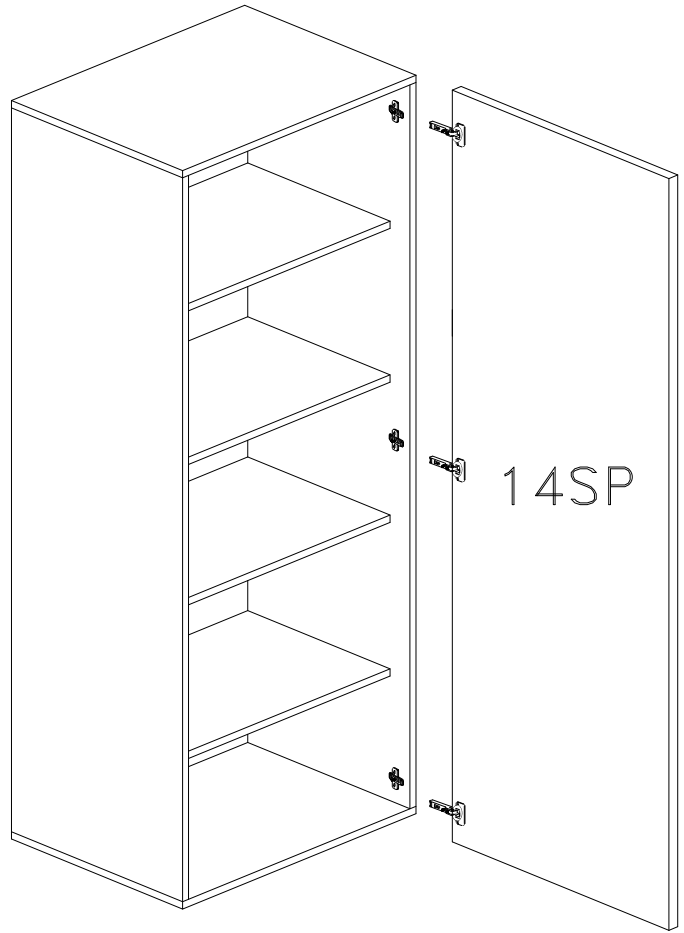
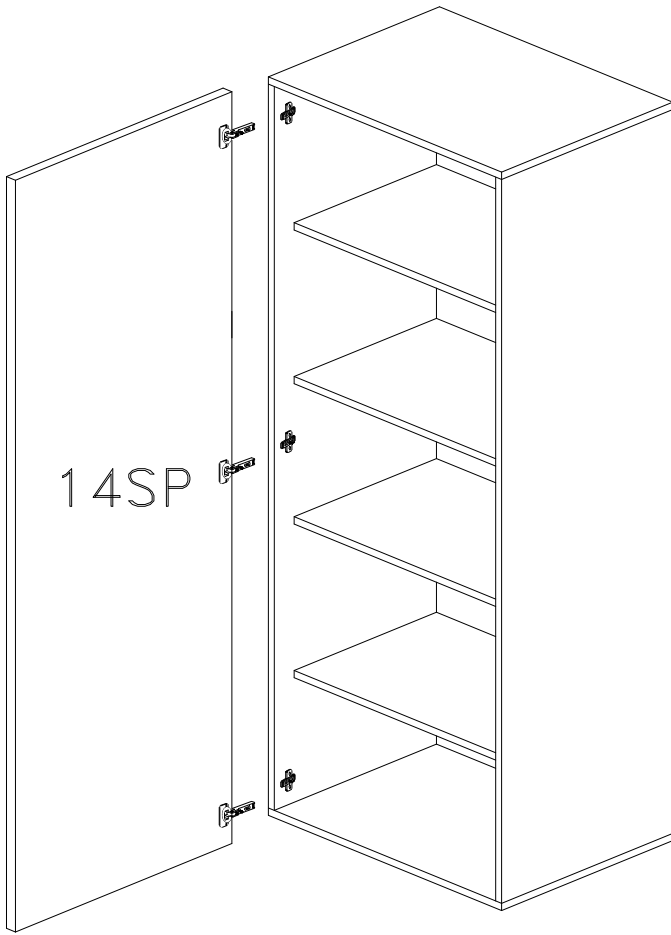

Cher client,
 l'installation des meubles suspendus doit être effectuée par un personnel compétent.
 Les fischers ne sont pas inclus dans la quincaillerie.
 Choisir les types des fischers pour le fixage apte au mur.
 S'assurer de l'adéquation du mur pour support sûr du meuble

Dear Customer
 The assembling of the hanging elements must be done by a competent staff.
 The fishers are not included in the hardware package.
 Choose the fisher more suitable to the type of the wall.
 Ensure the suitability of the wall for a secure support of the hanging element.

Sehr geehrter Kunde, die Montage der Haengeelemente muss von Fachpersonal ausgefuehrt werden! Bitte verwenden Sie eigene, der Beschaffenheit der Wand entsprechende Duebel. Zu Ihrer eigenen Sicherheit legen wir dem Beschlagbeutel keine Fischerduebel bei.

Gentile Cliente
 Il montaggio dei pensili deve essere effettuato da personale competente.
 I tasselli di fissaggio non sono compresi nella ferramenta.
 Scegliere il tipo di tassello per il fissaggio più adatto alla tipologia di muro.
 Assicurarsi l'idoneità della parete per un sostegno sicuro del pensile.

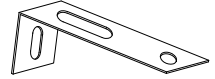
L418  x2
 4x18 mm.
 PST  x1

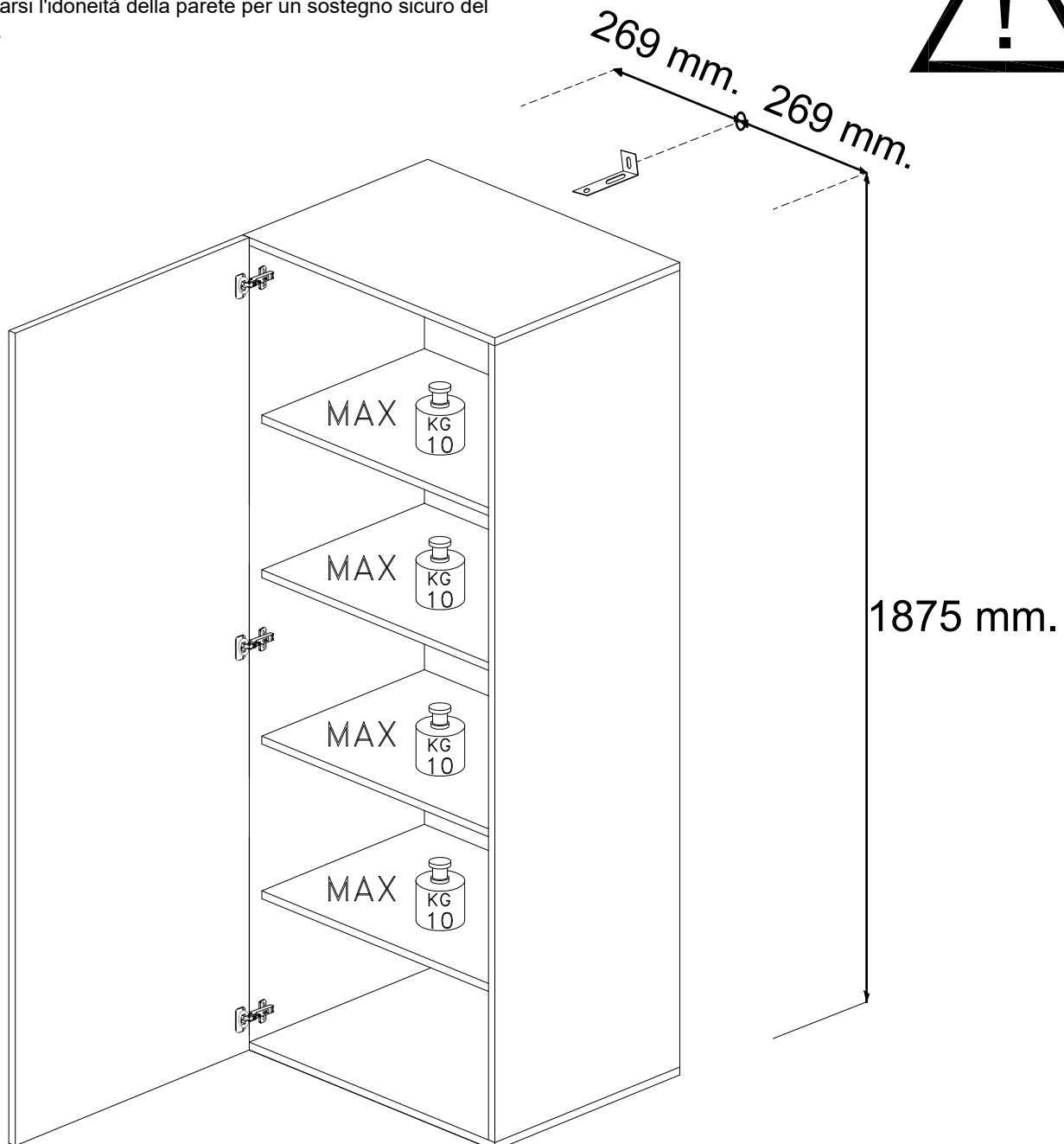
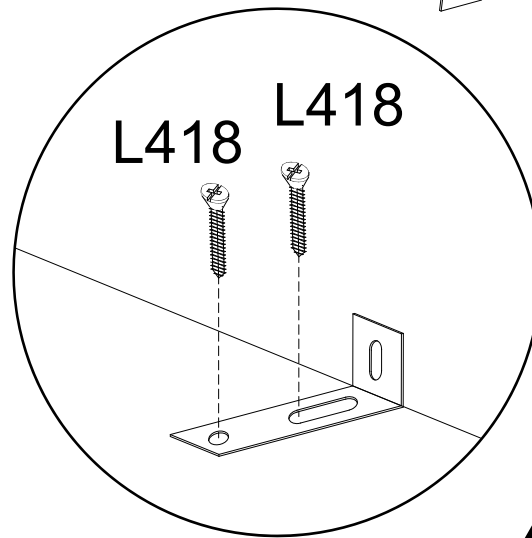

Montageanweisung / Installation instructions / Instruction de montage / Istruzioni di montaggio
montagehandleiding / Instrukcja montazu / Montaj talimatlar / Osszeszerelési útmutató / Nàvod k montázi /
Nàvod na montaz / Instrucțiune de montaj / Инструкция по монтажу / Montaj talimatina / Monteringsanvisningar
Upute za montažu / Instrucciones de Montaje / Navodila za montažo

INFINITY 2.0

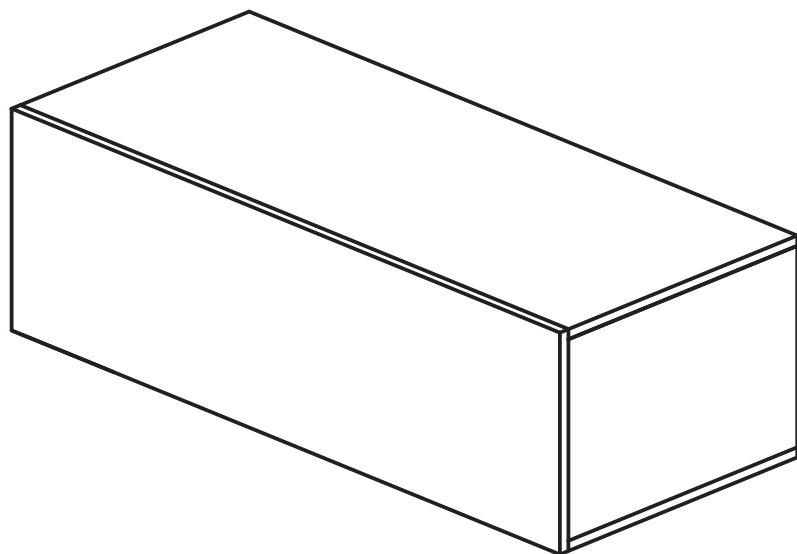
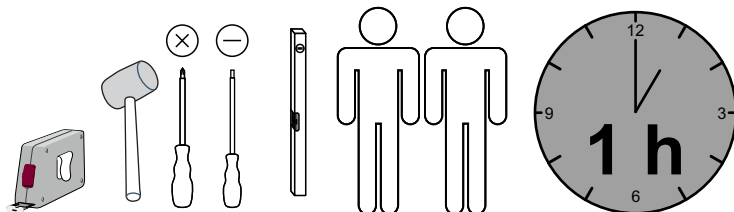

D – bitte lesen sie diese montageanleitung gut durch,
Da wir für fehler, die durch falsche montage entstehen,
Keine haftung übernehmen!

Gb – please read these installation instructions
Through carefully as we cannot accept any liability
For faults occurring as a result of incorrect installation!

Cz – přečtěte si prosím pozorně tento návod k montáži,
Aby jste předešli chybám vzniklých špatnou montáží,
Za které neručíme!

F – veuillez lire attentivement cette notice de montage,
Car nous déclinons toute responsabilité en cas d'erreurs
Découlant d'un montage erroné !

I – prego leggere attentamente le istruzioni per il montaggio,
Poiché decliniamo qualsiasi responsabilità
Per difetti derivanti da montaggio errato.

S - läs monteringsanvisningarna noggrant.
Vi avsåger oss allt ansvar för defekter som
Uppstår p.g.a. Felaktig montering.

Hr – pažljivo pročitajte upute za montažu,
Jer otklanjamo svaku odgovornost za pogreške
Nastale uslijed pogrešne montaže.

Slo – prosimo, da pozorno preberete navodila za montažo,
Saj zavračamo vsakršno odgovornost za napake,
Ki bi nastale zaradi napačne montaže.

Nl – leest u alstublieft deze montagehandleiding goed door,
Voor fouten door verkeerde montage zijn wij niet verantwoordelijk.

Pl – prosze uwaznie zapoznac sie z instrukcja montazu,
Poniewaz nie ponosimy odpowiedzialnosci za niewlasciwy montaz.

HU – Kérjük, olvassa el figyelmesen
ezt az összeszerelési útmutatót,
mert a helytelen összeszerelésből
a dódó hibákért nem vállalunk felelősséget!

SK – Prosíme, dobre prečítajte si tento návod na montáž,
pretože nepreberáme žiadne ručenie za chyby,
ktoré vzniknú na základe chybnej montáže!

RO – Vă rugăm să cititi cu atenție aceste instrucțiuni
de montaj deoarece nu preluăm garanția pentru defecte
ce apar datorită unui montaj incorect!

RUS – Пожалуйста, внимательно ознакомьтесь ù
с данной инструкцией по монтажу, поскольку мы не
несем ответственности за ошибки, причиной которых
является неправильный монтаж.

TU – İlkonce kullanma klavuzunu iyi okuyun,
yalnis montaj yapasaniz bunun sorumlusu biz degiliz.

ES – Se ruega leer con atención las instrucciones
de montaje debido a que declinamos cualquier
responsabilidad
por defectos derivados de un montaje erróneo.

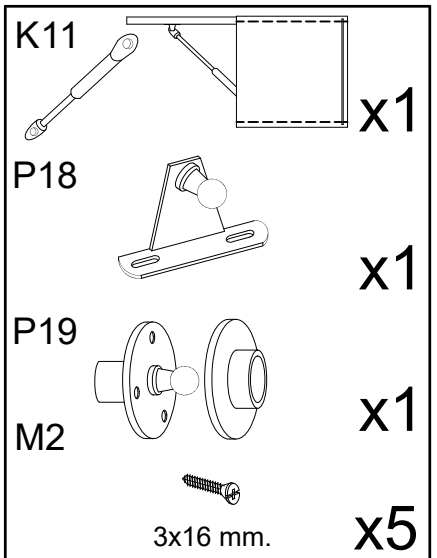
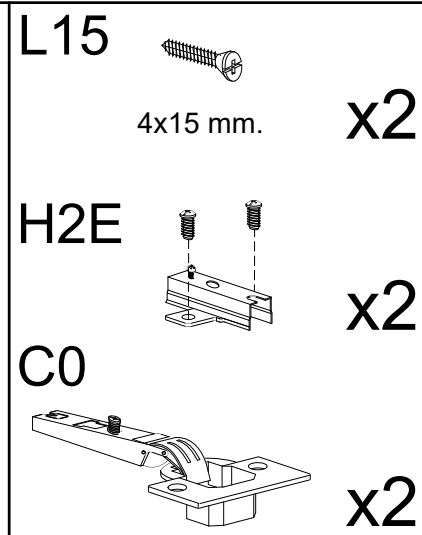
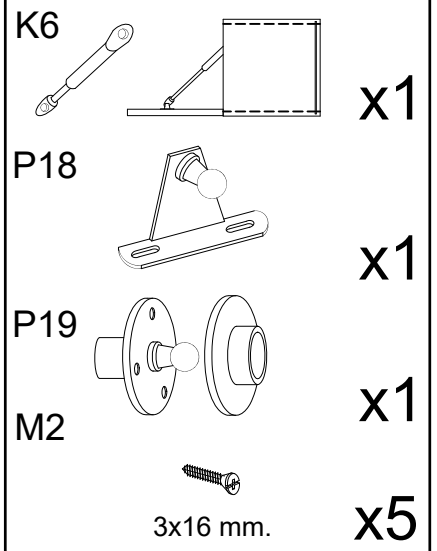
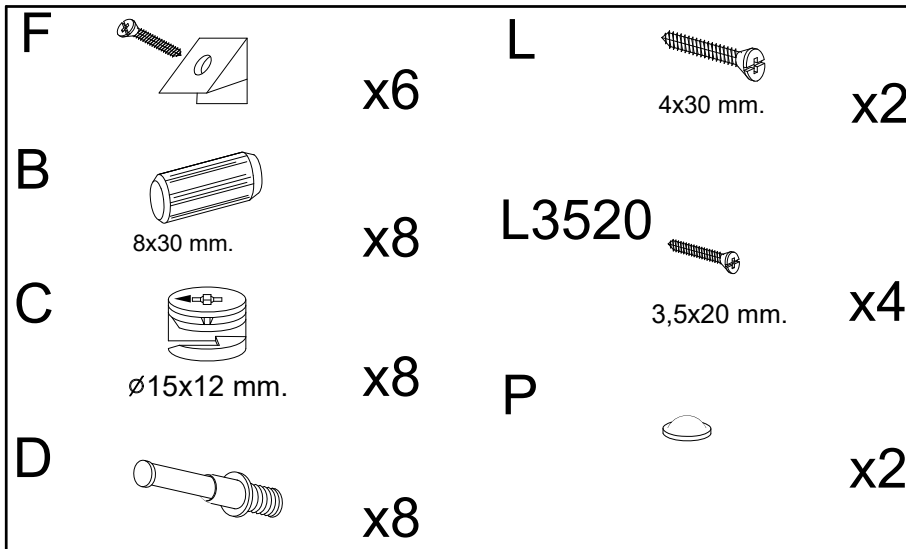
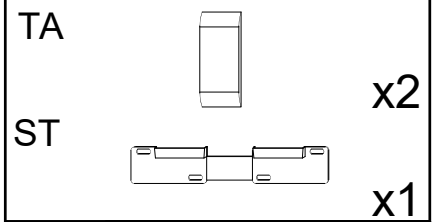
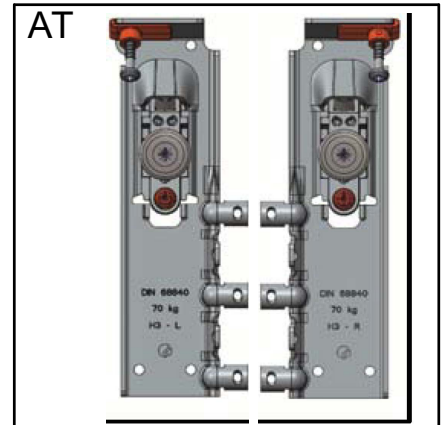
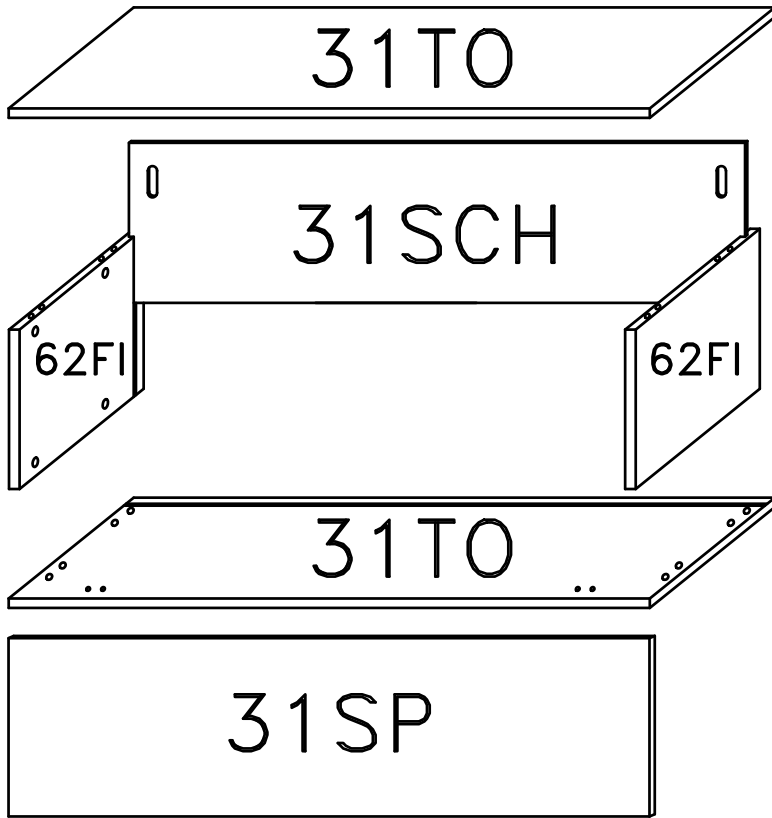

1

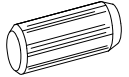
B  **8x30 mm.** **x8**

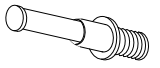
D  **x8**

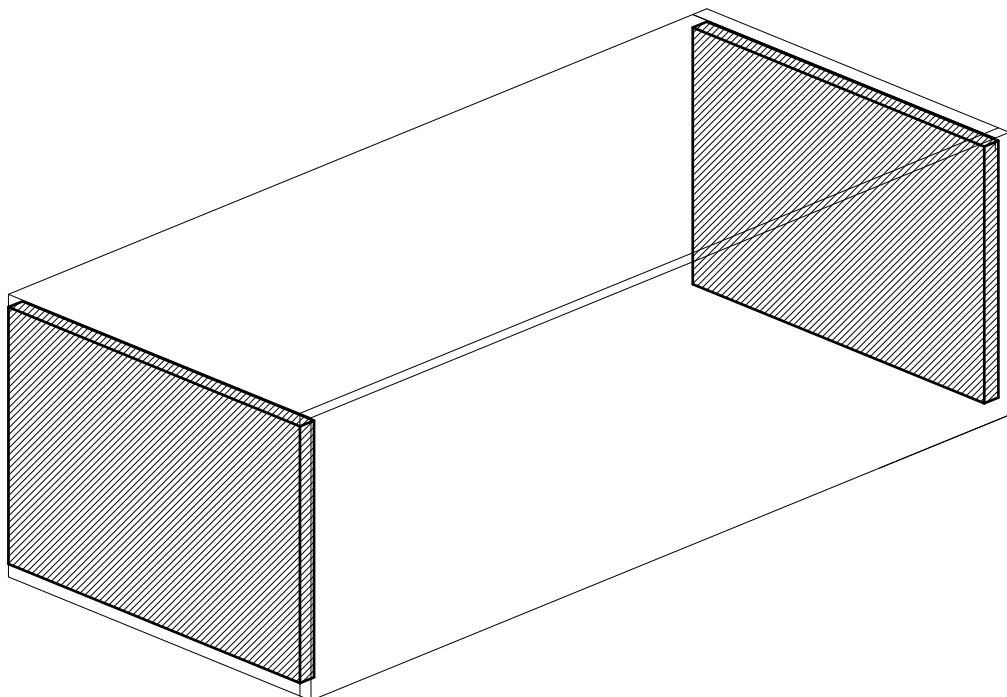
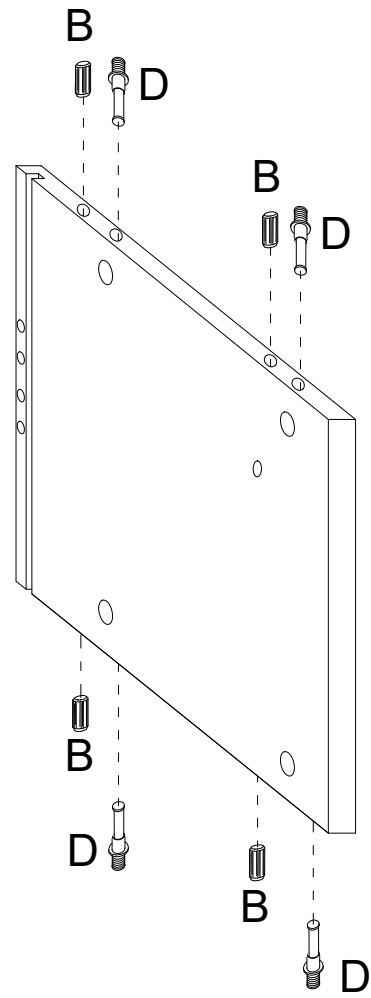
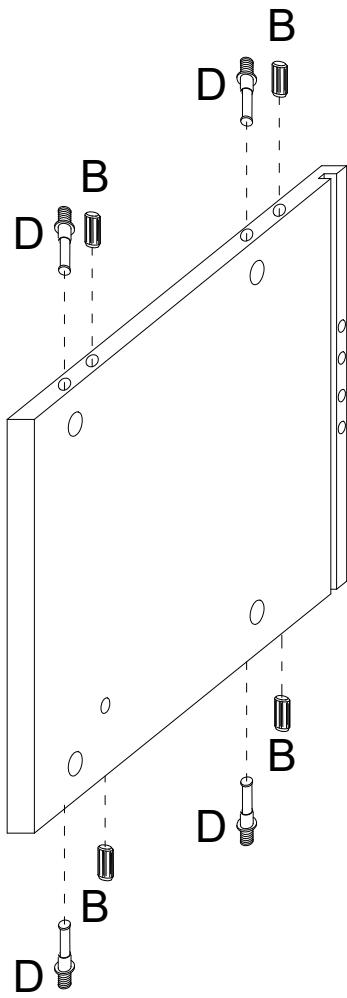

2

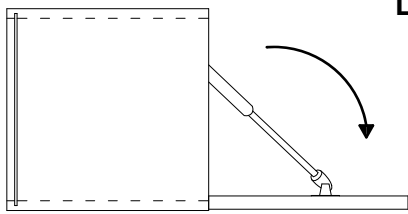

L 4x30 mm. x3

C \varnothing 16 mm. x12

M2 3x16 mm. x3

H2E

P19 x3

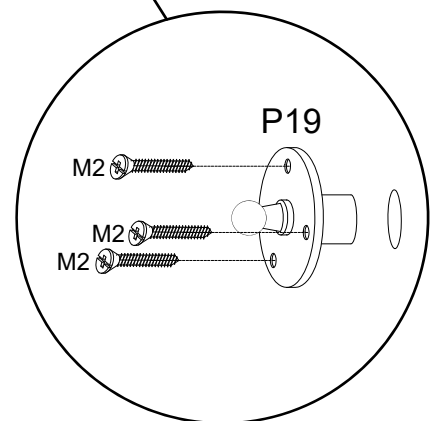
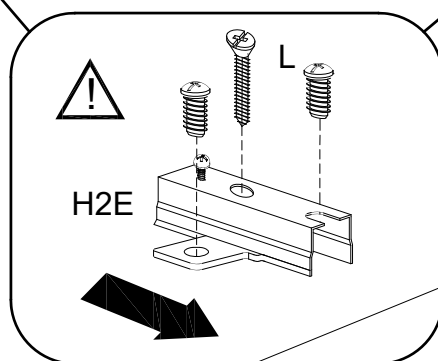
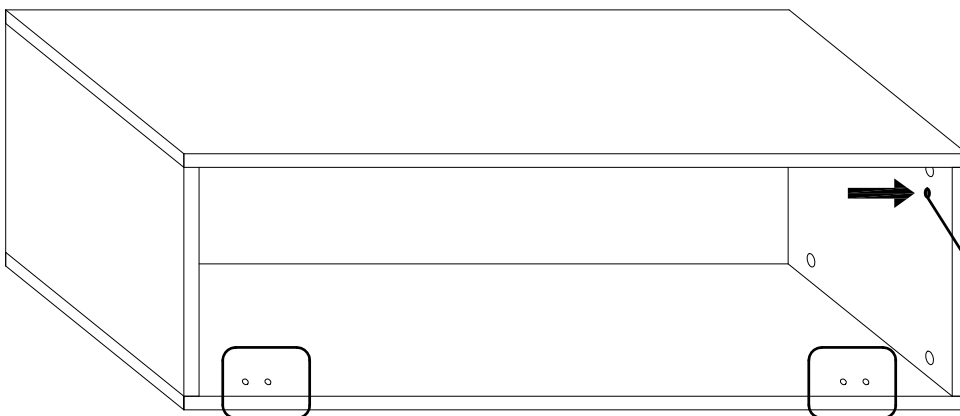
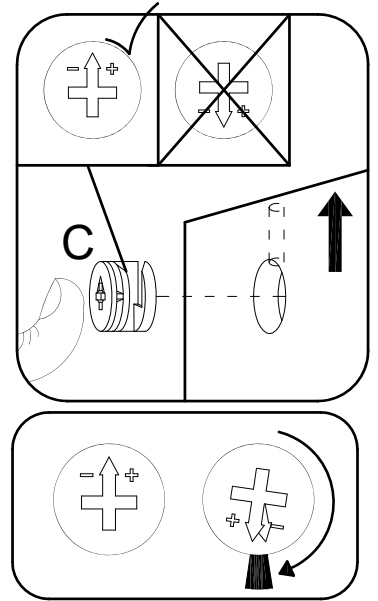
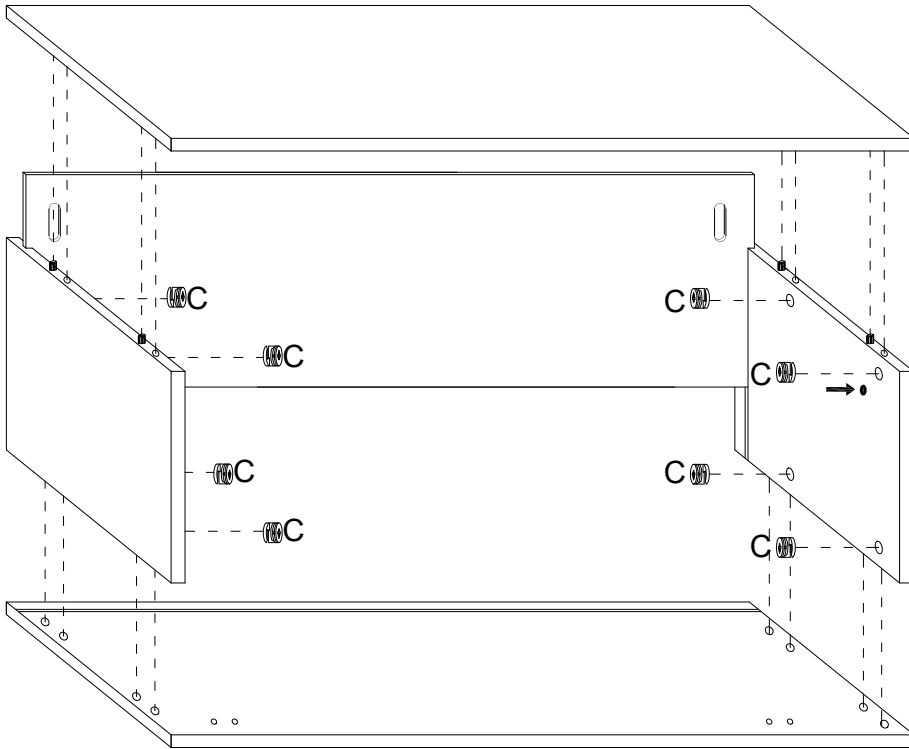
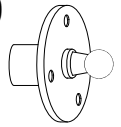
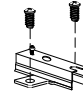

2

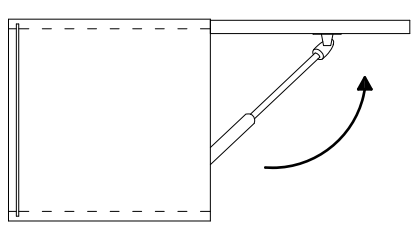

H2E

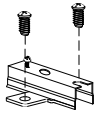

x3



C



∅16 mm.

x12

M2

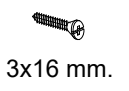

3x16 mm.

x3

P19

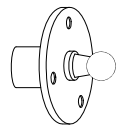

x1

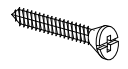



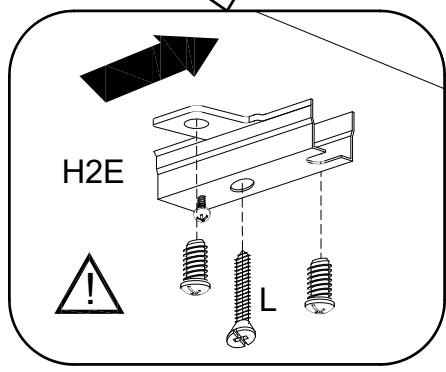
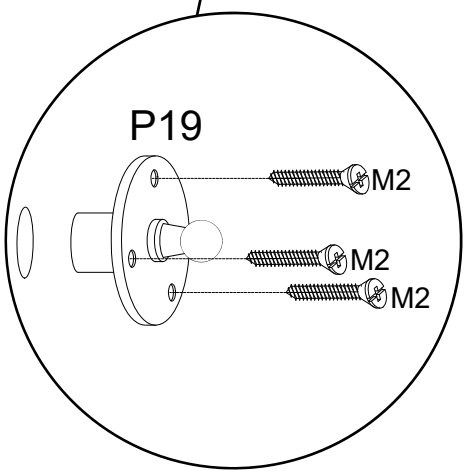
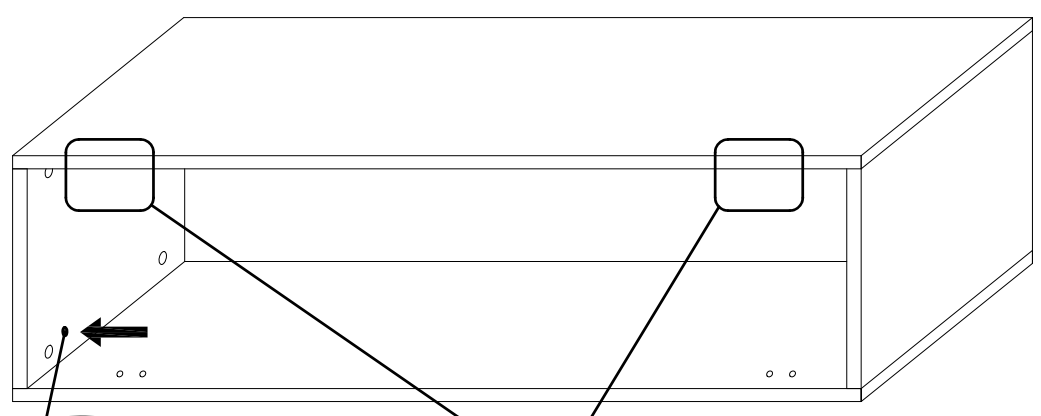
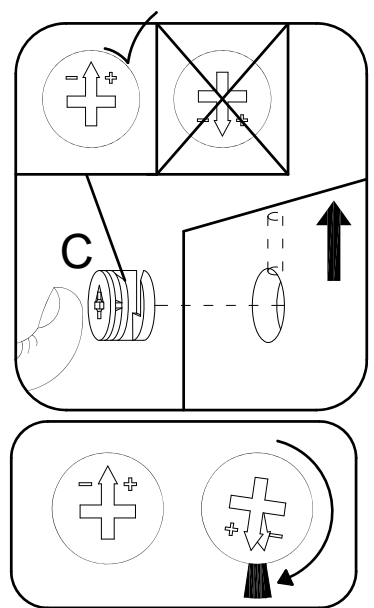
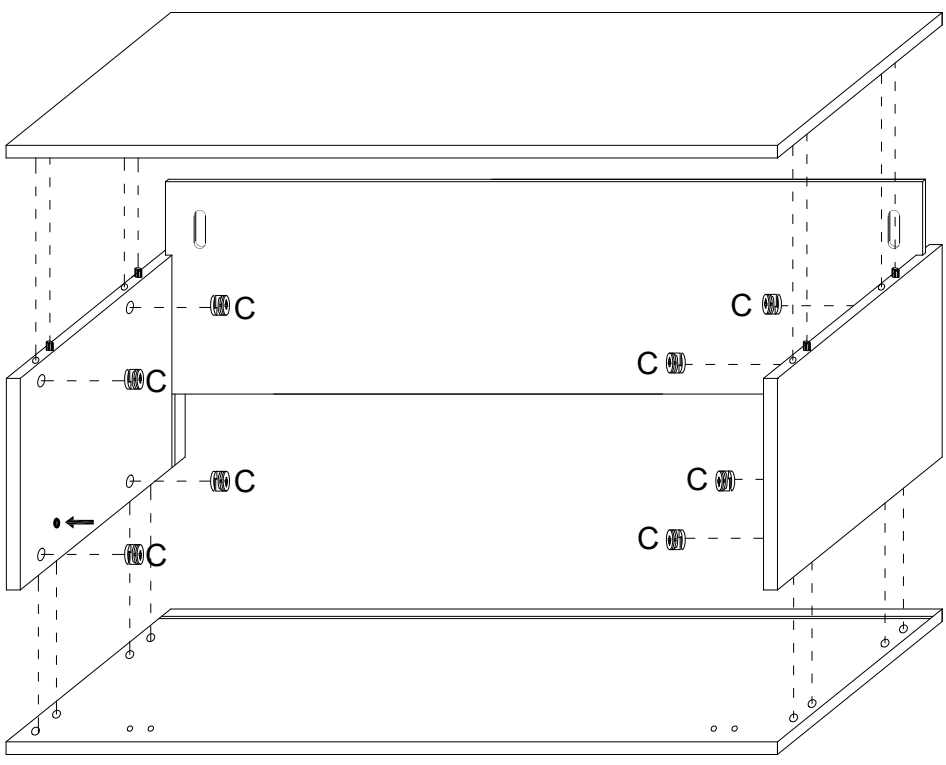

4x30 mm.

x3

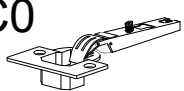

3



- C0  x2
- P18  x1
- P  x2
- M2  3x16 mm. x2
- L15  4x15 mm. x4

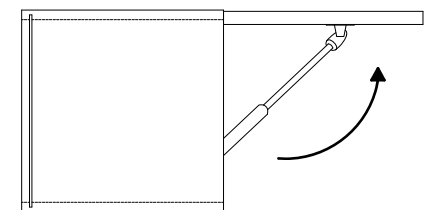
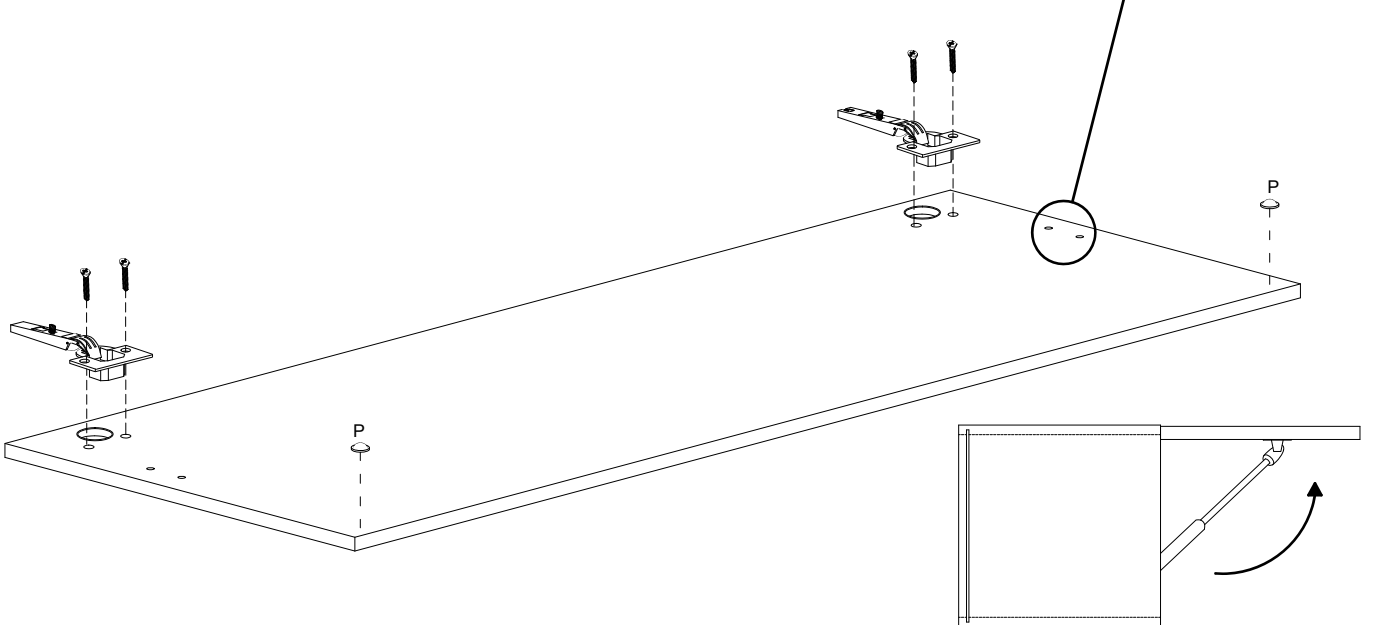
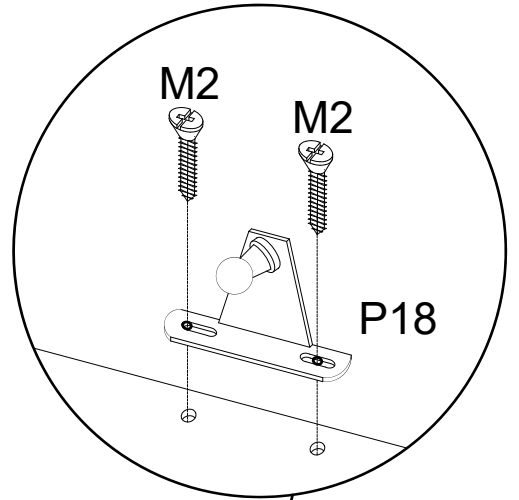
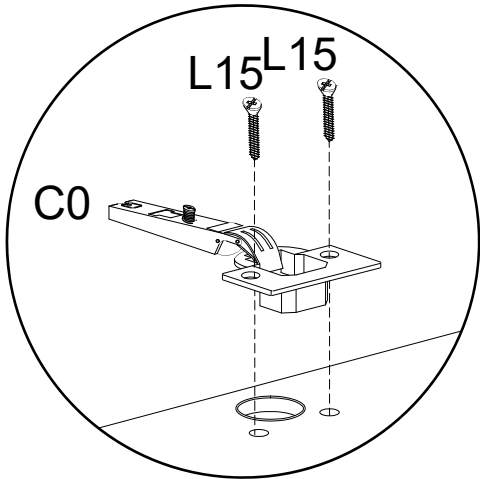
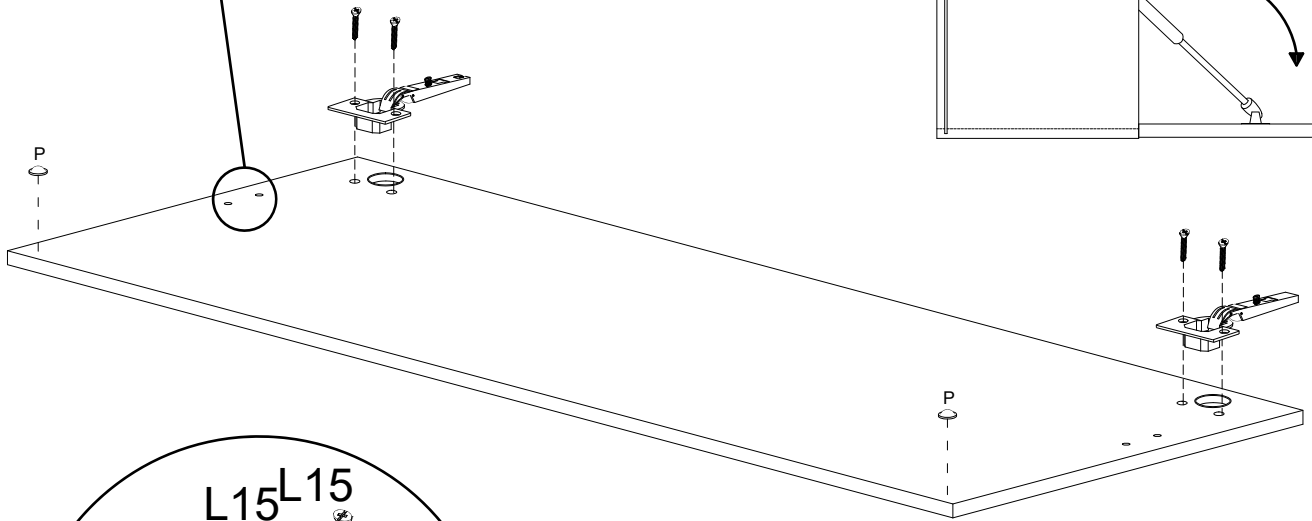
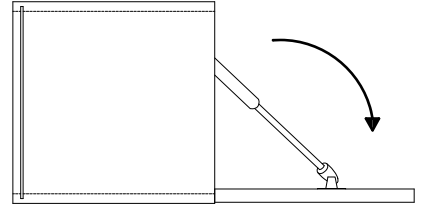
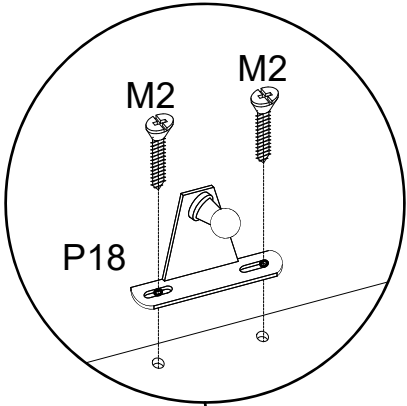

4

F

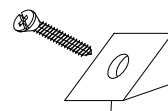

x6

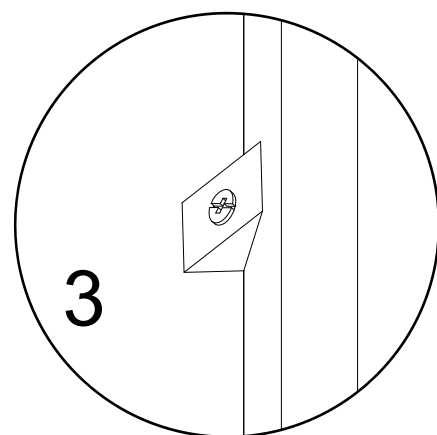
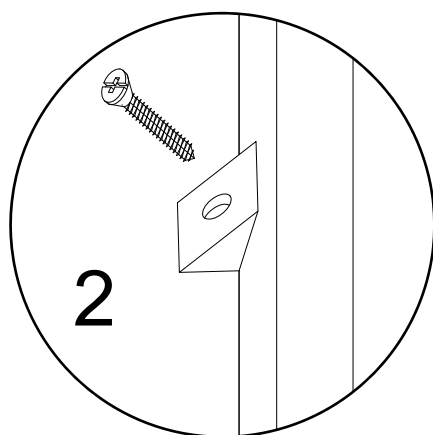
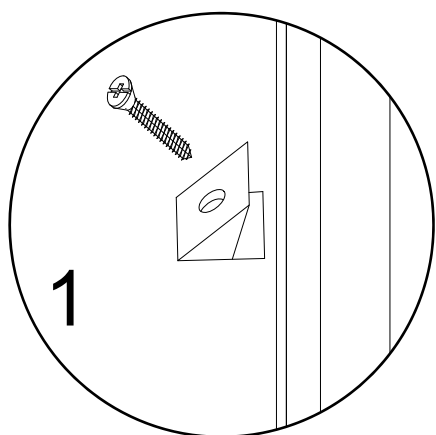
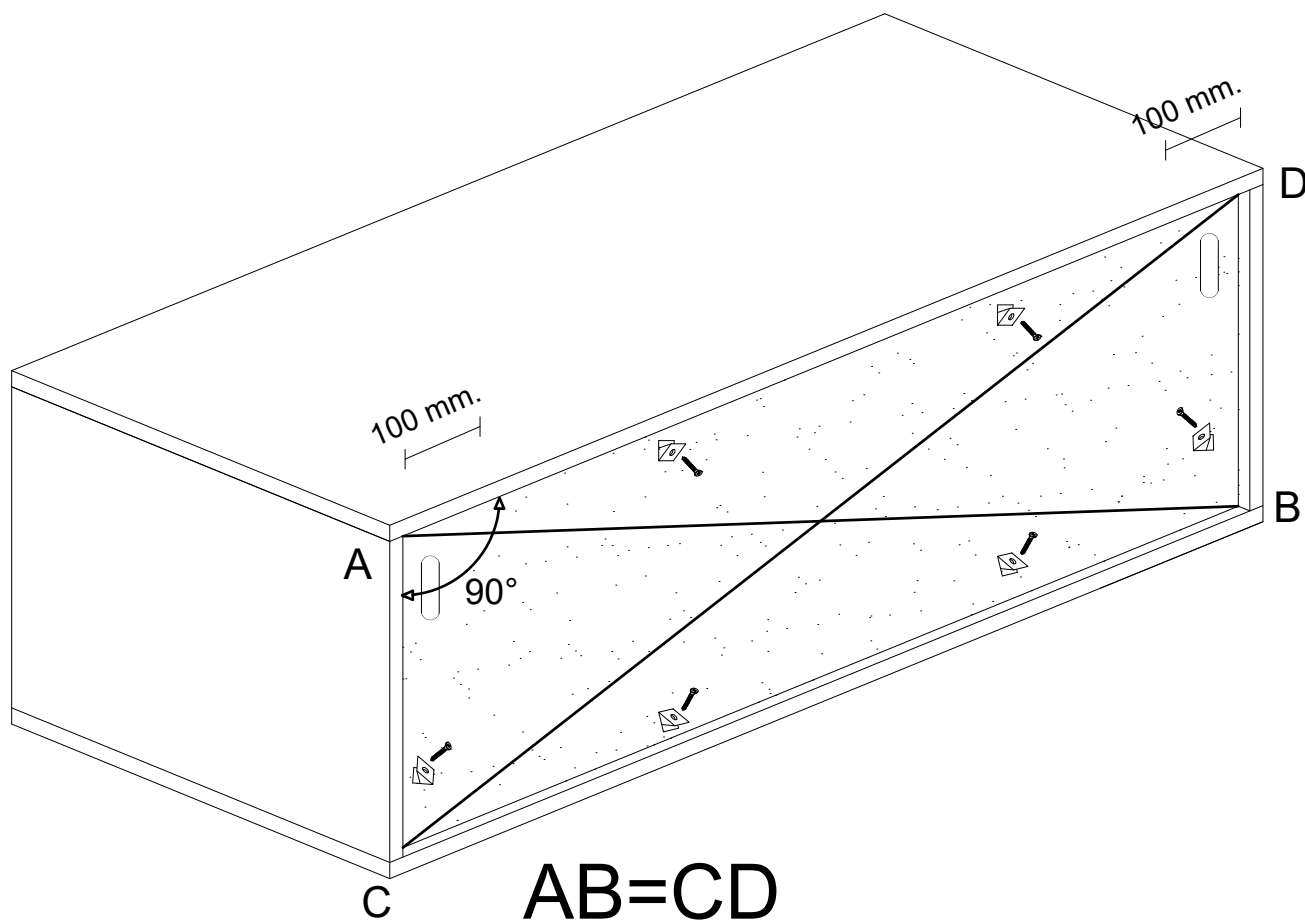

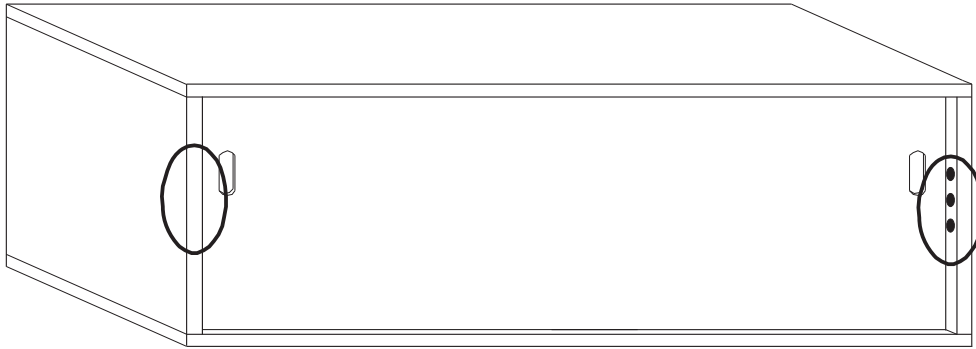

AT

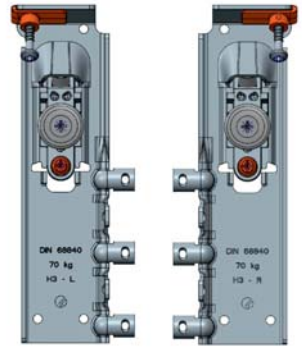

L3520



3,5x20 mm. **x4**

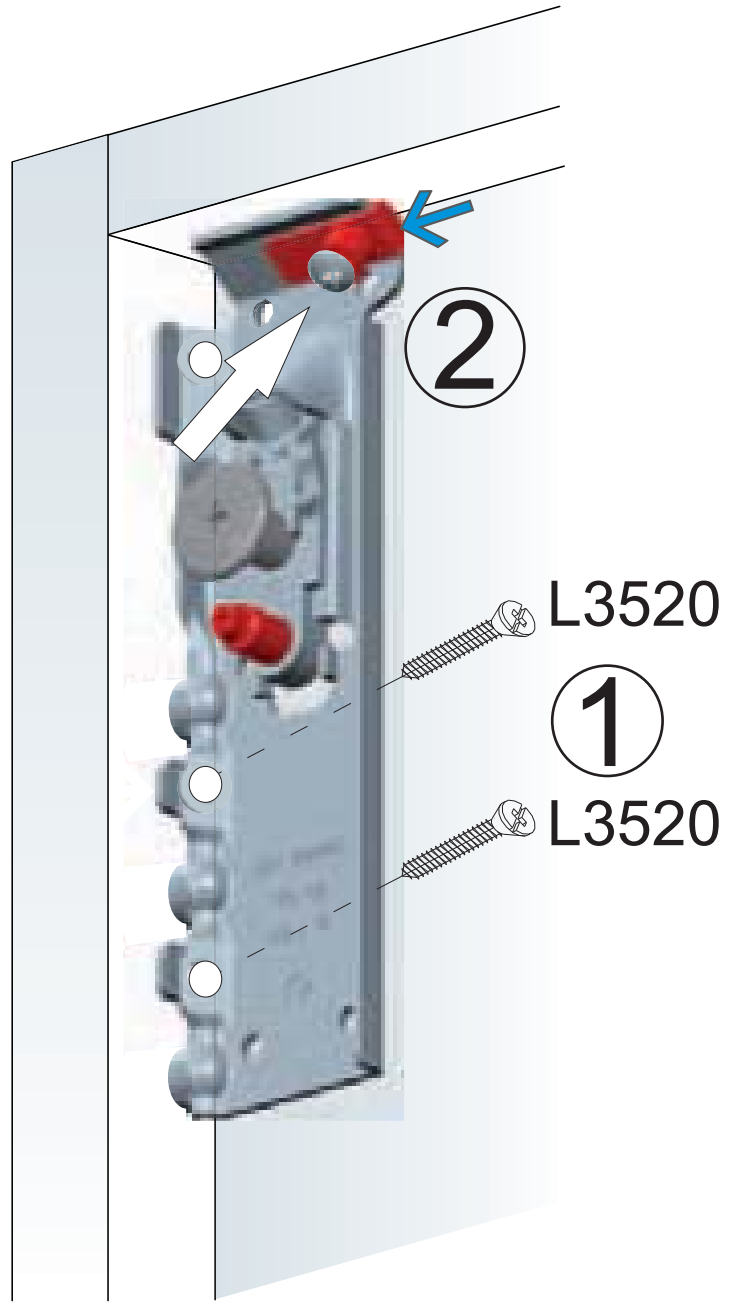
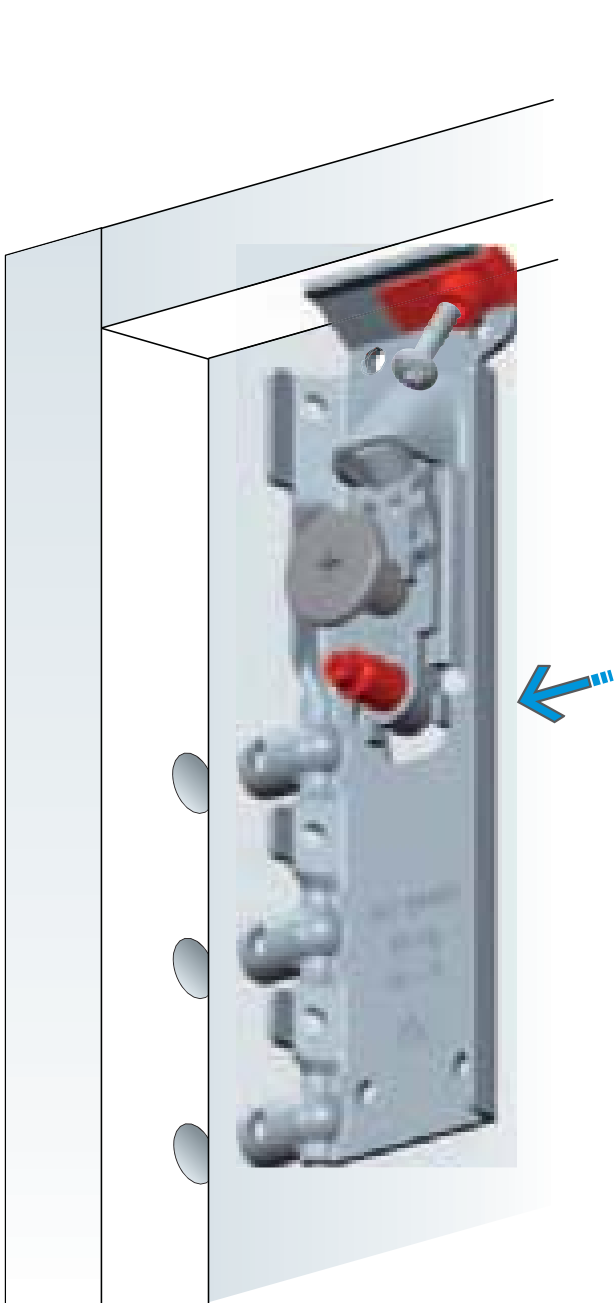

5



ST

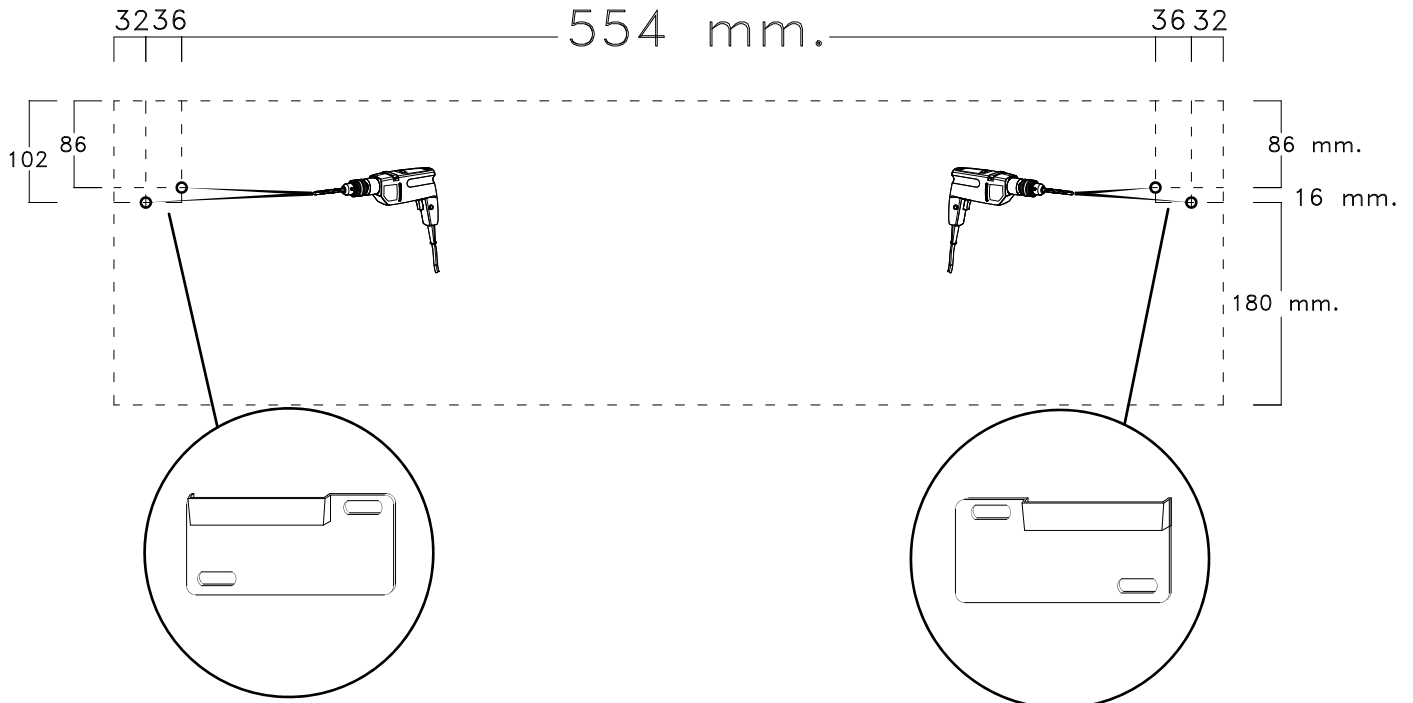
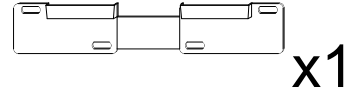

Gentile Cliente,

Il montaggio dei pensili deve essere effettuato da personale competente. I tasselli di fissaggio non sono compresi nella ferramenta. Scegliere il tipo di tassello per il fissaggio più adatto alla tipologia di muro. Assicurarsi l'idoneità della parete per un sostegno sicuro del pensile.

Dear Customer,

The assembling of the hanging elements must be done by a competent staff. The wall plugs are not included in the hardware package. Choose the wall plugs more suitable to the type of the wall. Ensure the suitability of the wall for a secure support of the hanging element.

Sehr geehrter Kunde, die Montage der Hängeelemente muss von Fachpersonal ausgeführt werden!

Bitte verwenden Sie eigene Dübel, die der Beschaffenheit der Wand entsprechen. Zu Ihrer eigenen Sicherheit legen wir dem Beschlagbeutel keine Dübel bei.

Cher client, les éléments muraux ne peuvent être installés que par du personnel qualifié !

Veuillez utiliser vos propres ancrages adaptés à la nature du mur. Pour votre sécurité, nous n'incluons pas de chevilles dans le matériel.

Estimado cliente,

el montaje de los muebles colgados en la pared debe ser realizado por personal competente. Los tacos de fijación no están incluidos en la bolsa de herrajes. Elija el tipo de anclaje de fijación que mejor se adapte al tipo de pared. Asegúrese de que la pared sea adecuada para un soporte seguro del mueble colgado en la pared.

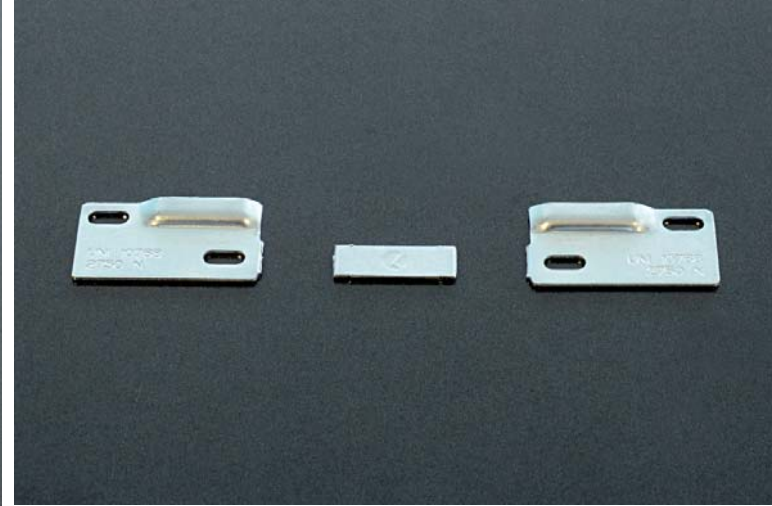
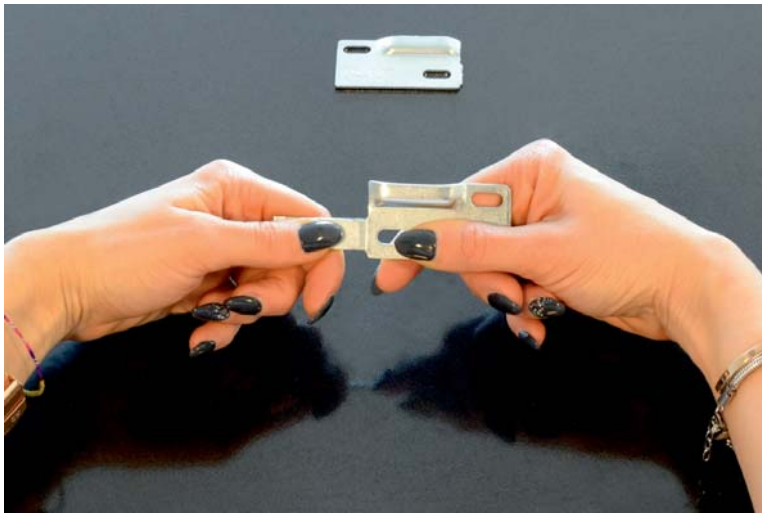
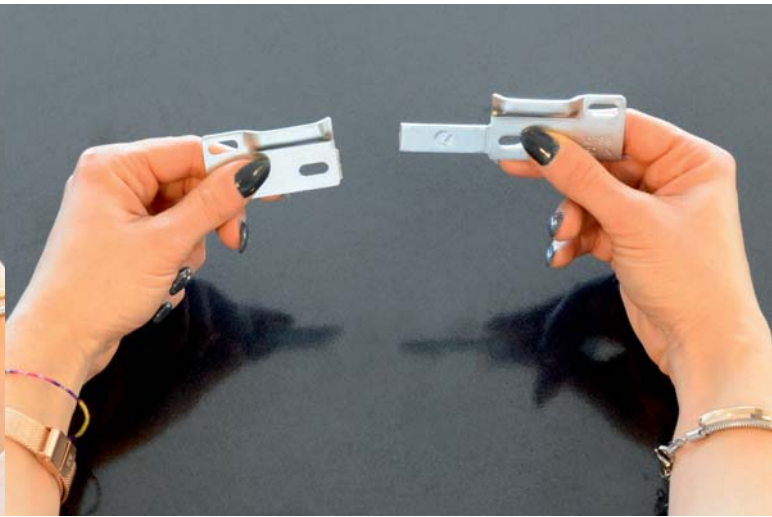
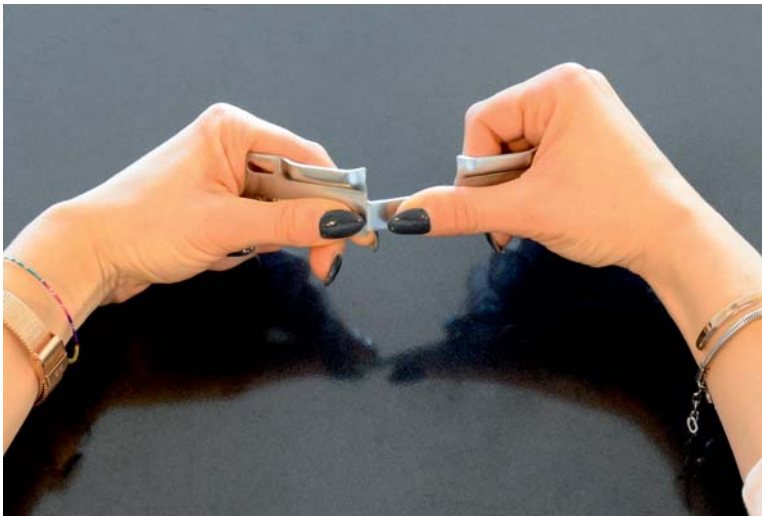
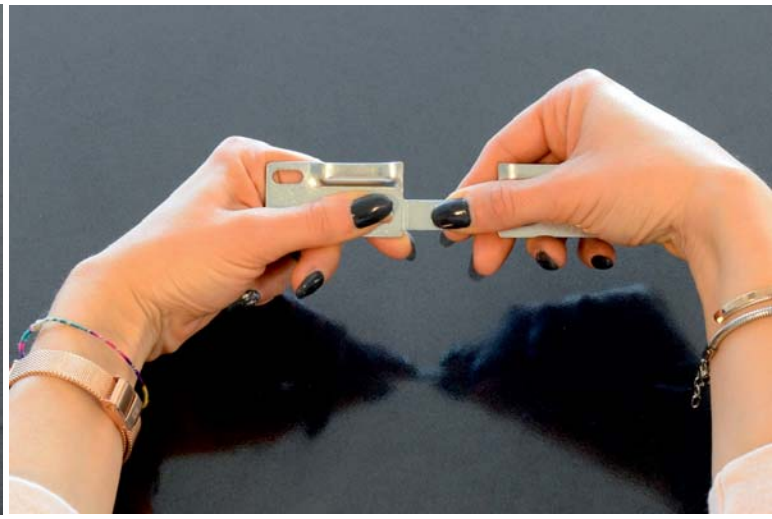
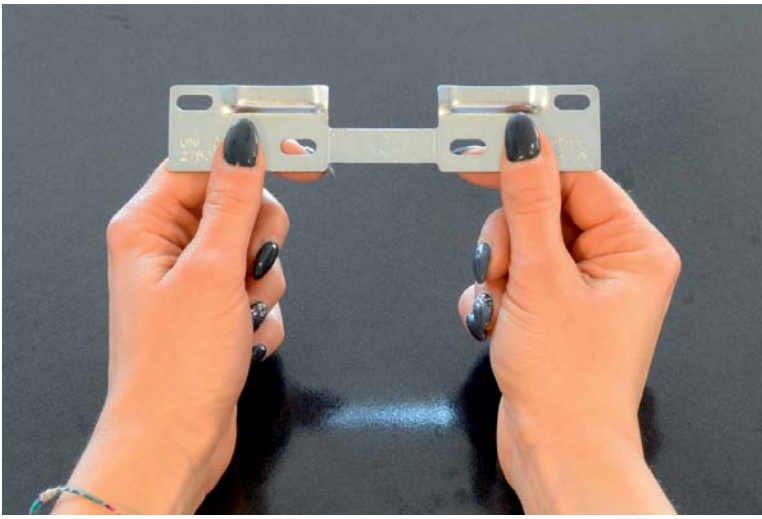

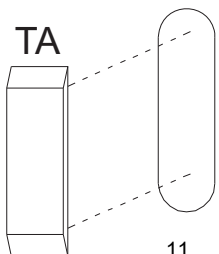
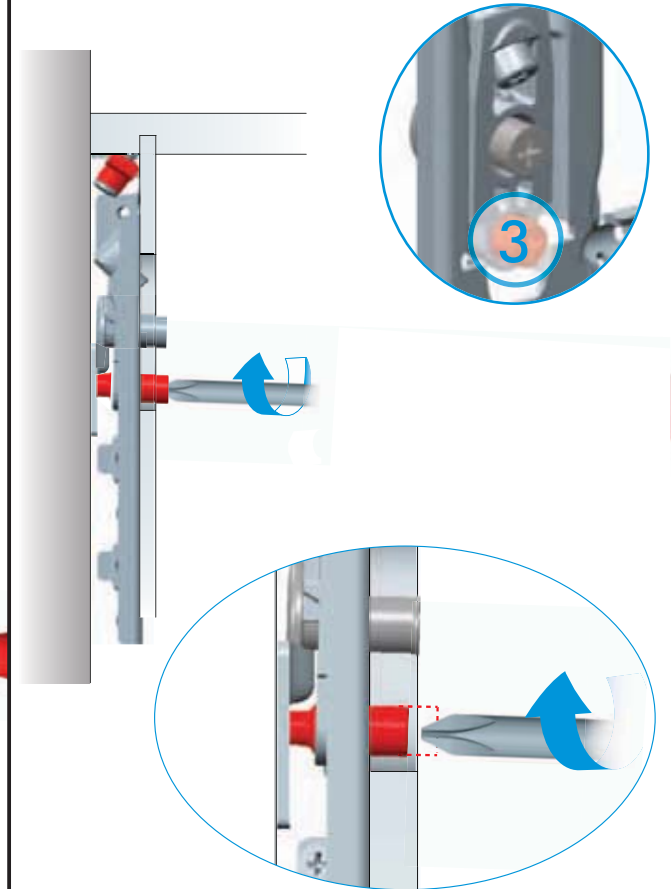
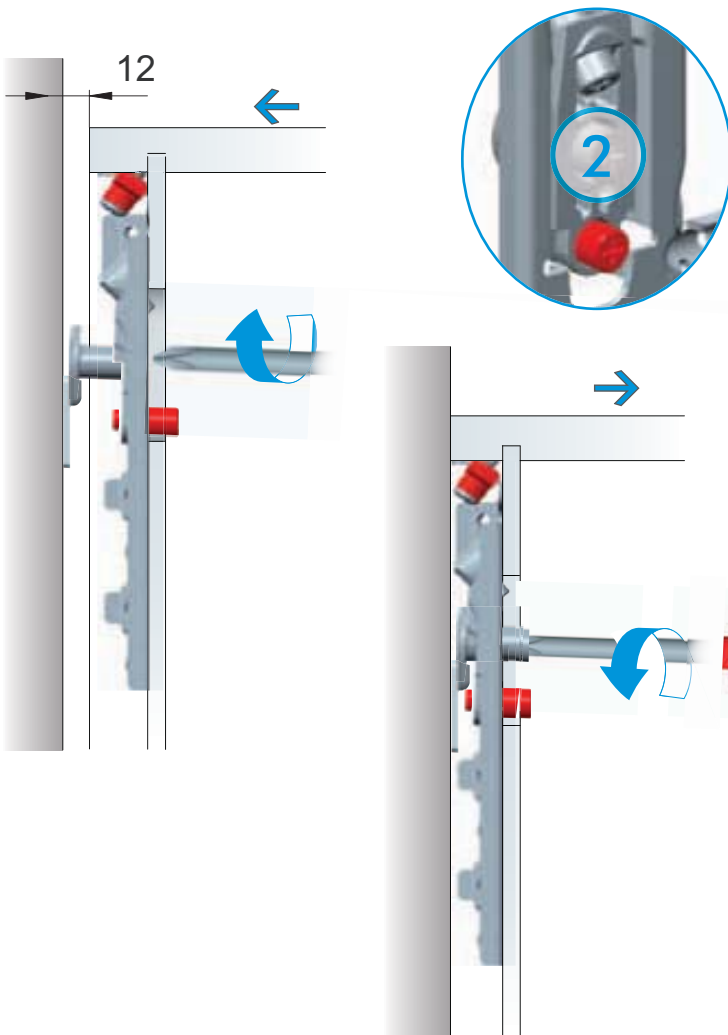
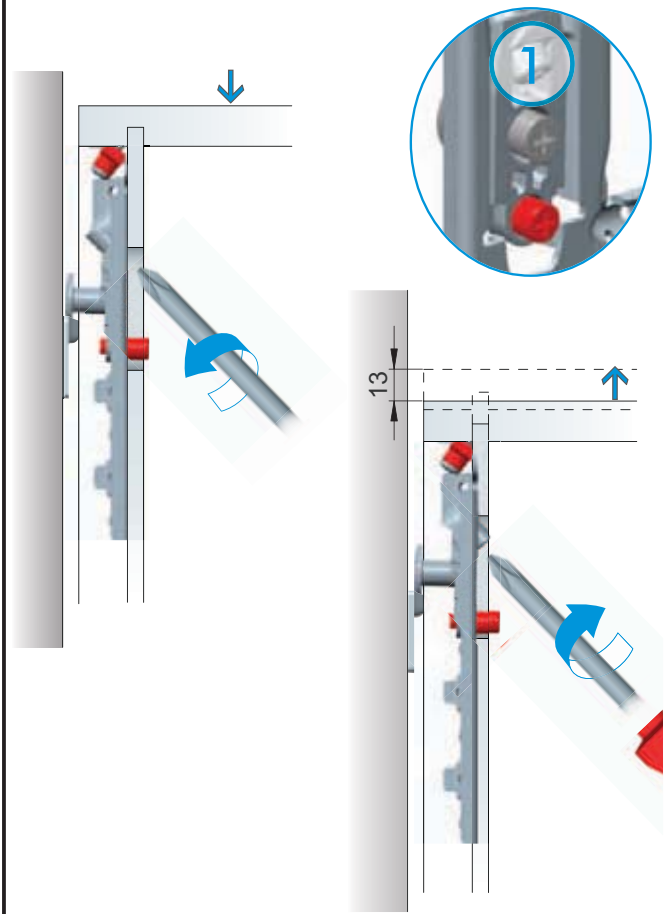
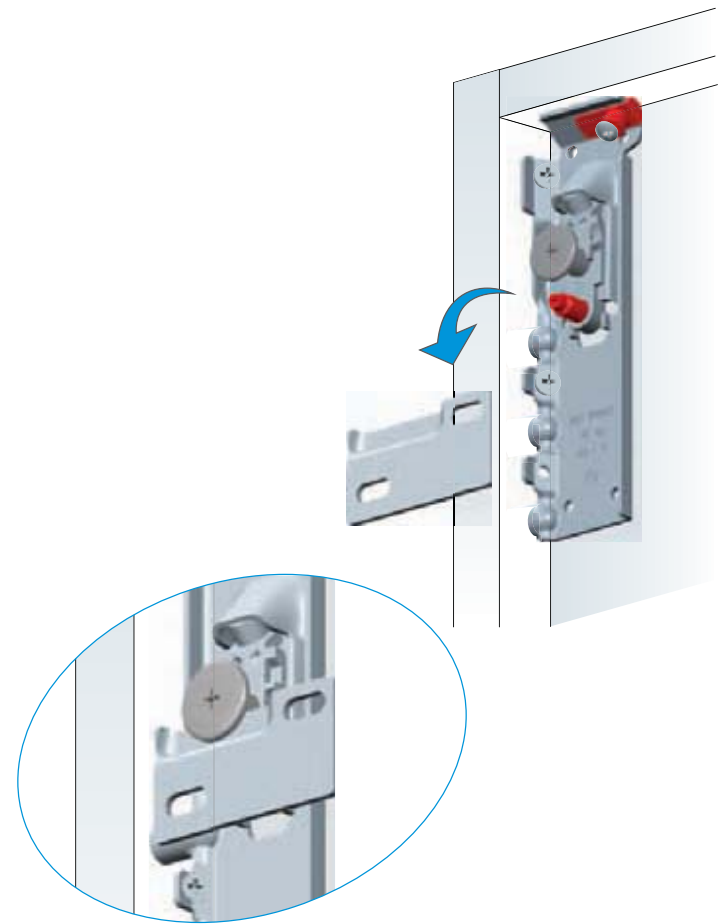

8

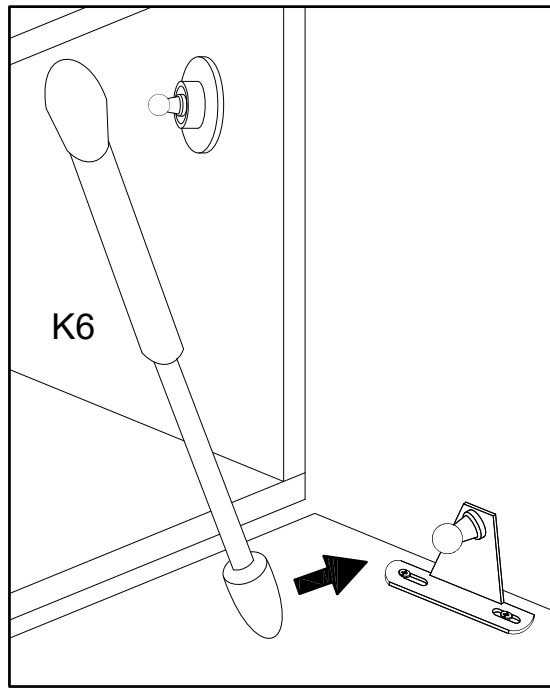
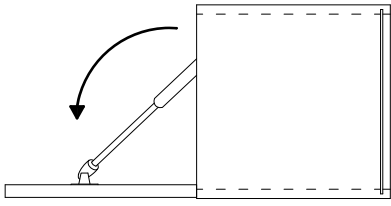

P19



x1

K6

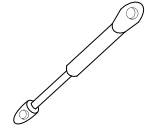

x1

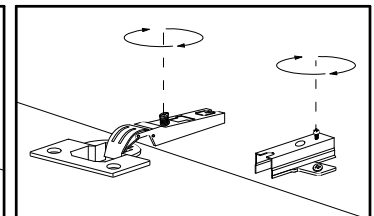
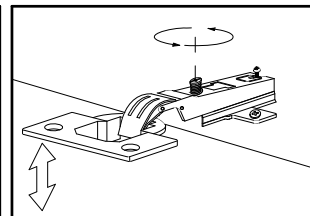
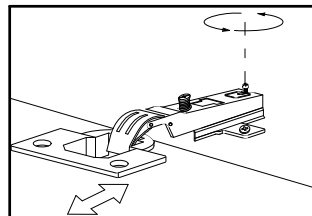
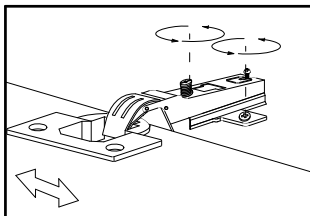
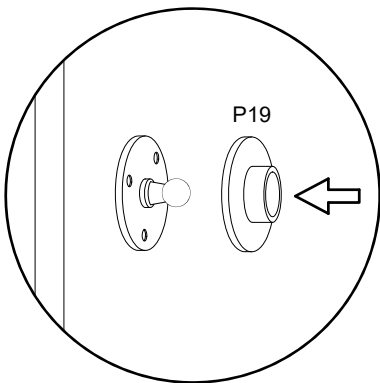
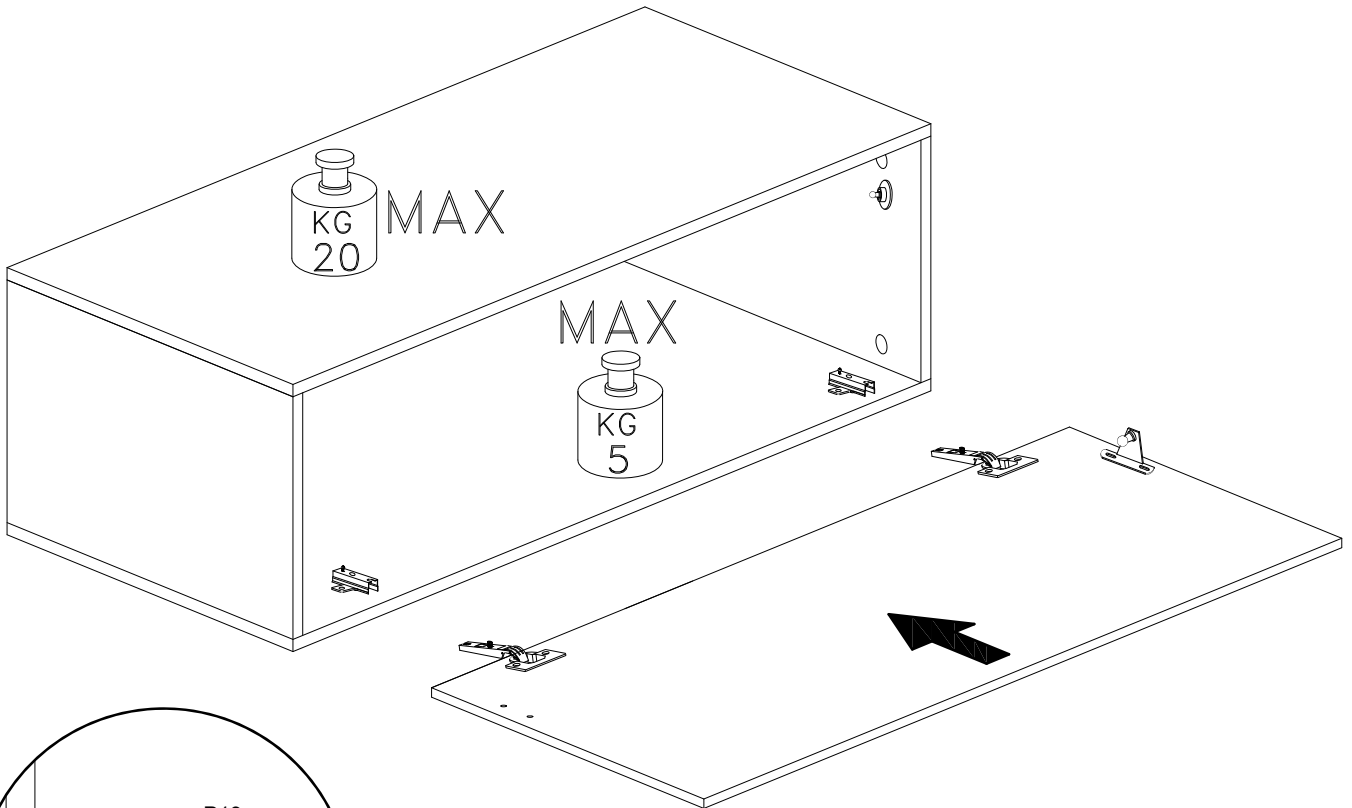

8

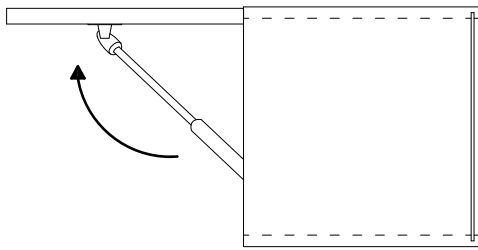

P19

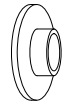

x1

K11



x1

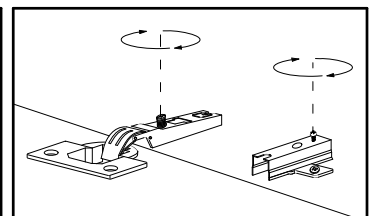
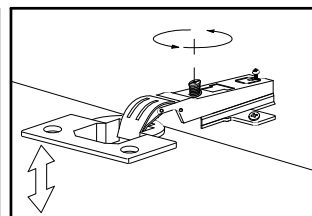
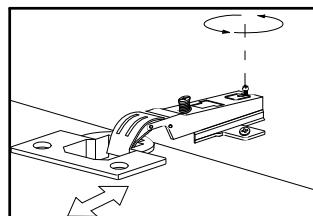
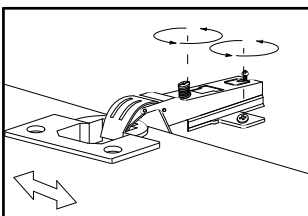
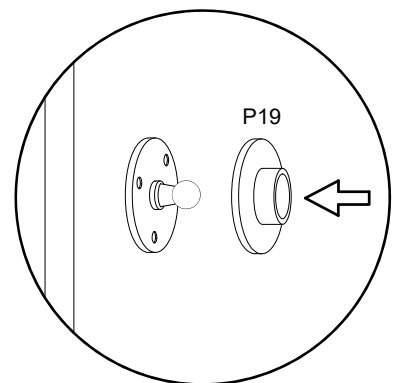
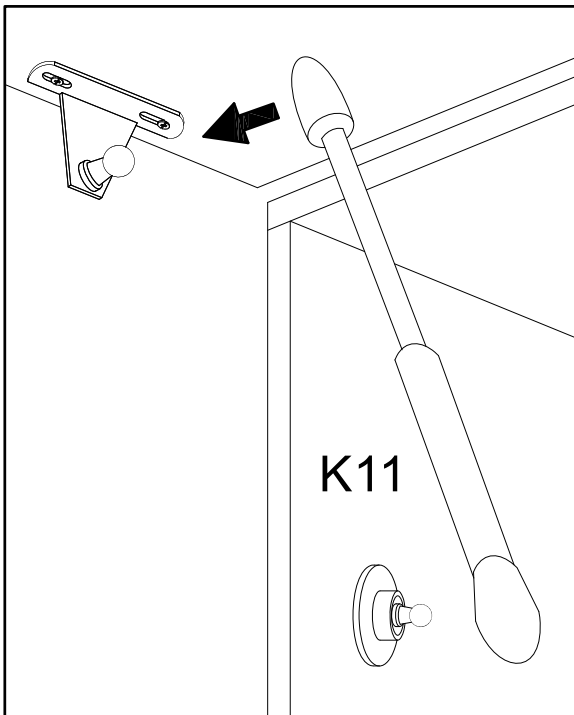
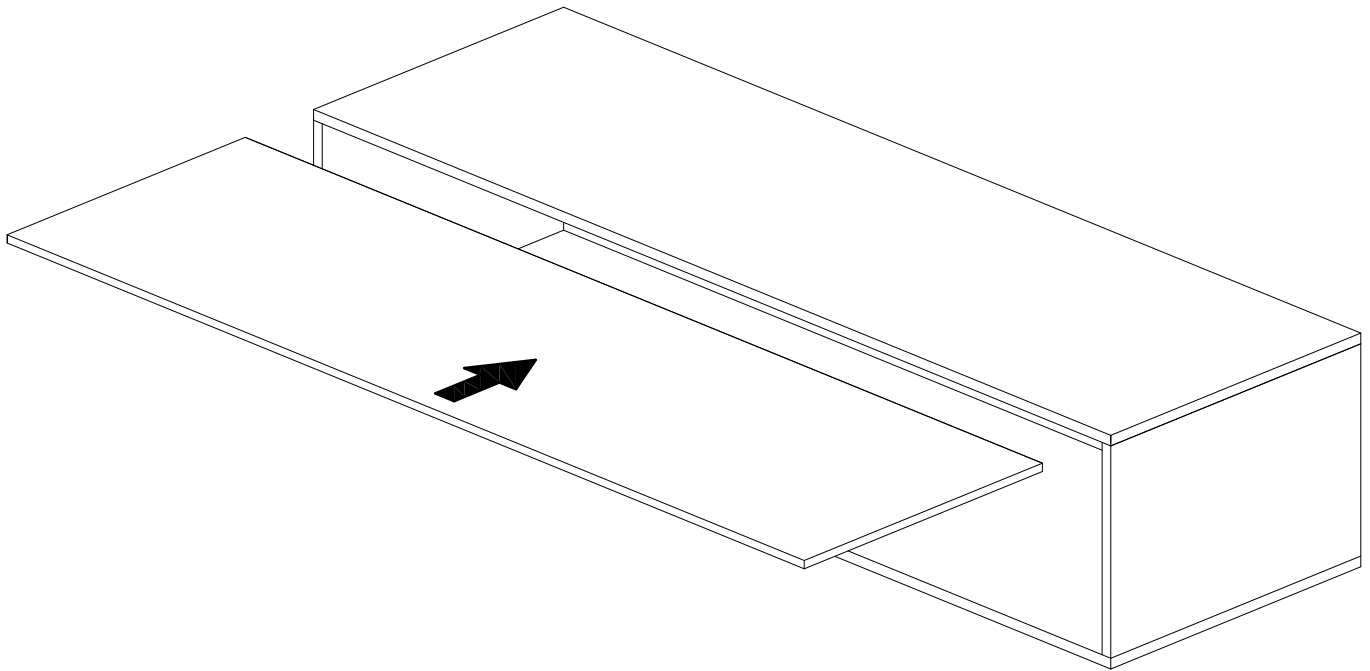

-81

Montageanweisung / Installation instructions / Instruction de montage / Istruzioni di montaggio
montagehandleiding / Instrukcja montazu / Montaj talimatlar / Osszeszerési útmutató / Nàvod k montázi /
Nàvod na montaz / Instructiune de montaj / Инструкция по монтажу / Montaj talimatina / Monteringsanvisningar
Upute za montažu / Instrucciones de Montaje / Navodila za montažo

INFINITY 2.0

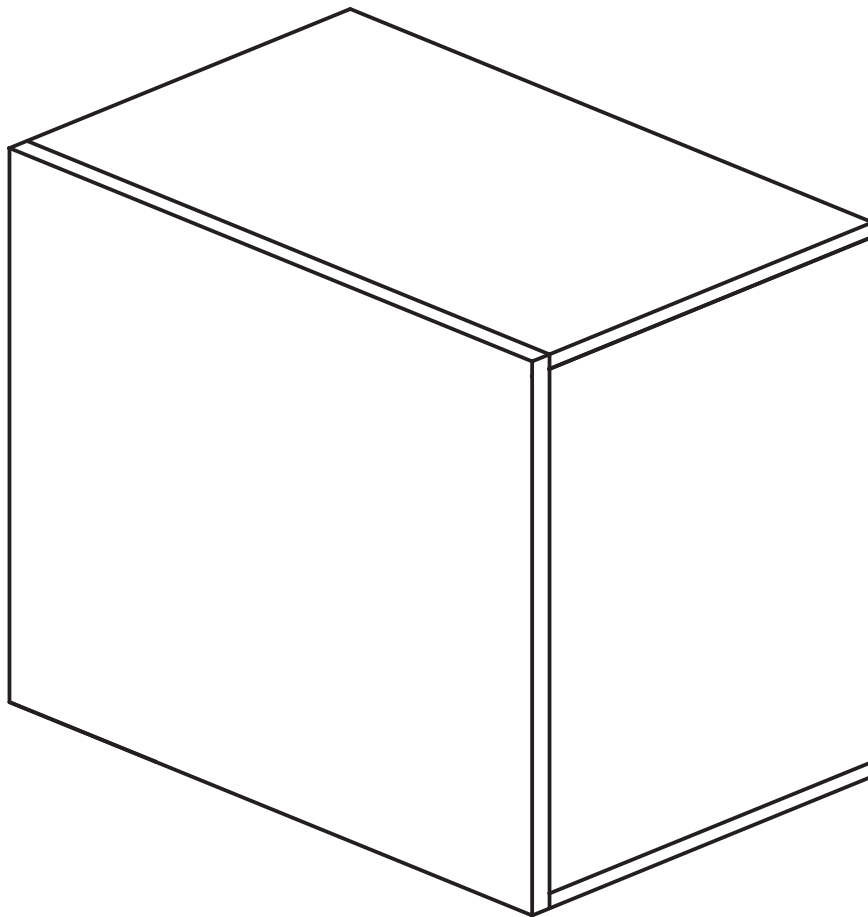
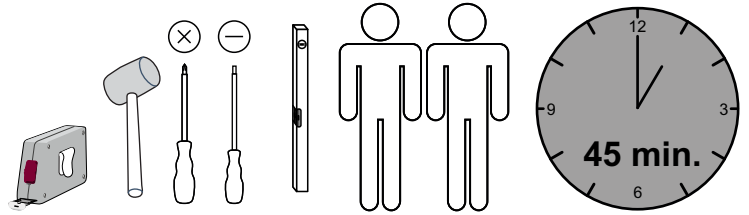

D – bitte lesen sie diese montageanleitung gut durch,
Da wir für fehler, die durch falsche montage entstehen,
Keine haftung übernehmen!

Gb – please read these installation instructions
Through carefully as we cannot accept any liability
For faults occurring as a result of incorrect installation!

Cz – přečtěte si prosím pozorně tento návod k montáži,
Aby jste předešli chybám vzniklých špatnou montáží,
Za které neručíme!

F – veuillez lire attentivement cette notice de montage,
Car nous déclinons toute responsabilité en cas d'erreurs
Découlant d'un montage erroné !

I – prego leggere attentamente le istruzioni per il montaggio,
Poiché decliniamo qualsiasi responsabilità
Per difetti derivanti da montaggio errato.

S - läs monteringsanvisningarna noggrant.
Vi avsåger oss allt ansvar för defekter som
Uppstår p.g.a. Felaktig montering.

Hr – pažljivo pročitajte upute za montažu,
Jer otklanjamo svaku odgovornost za pogreške
Nastale uslijed pogrešne montaže.

Slo – prosimo, da pozorno preberete navodila za montažo,
Saj zavračamo vsakršno odgovornost za napake,
Ki bi nastale zaradi napačne montaže.

Nl – leest u alstublieft deze montagehandleiding goed door,
Voor fouten door verkeerde montage zijn wij niet verantwoordelijk.

Pl – prosze uwaznie zapoznac sie z instrukcja montazu,
Poniewaz nie ponosimy odpowiedzialnosci za niewlasciwy montaz.

HU – Kérjük, olvassa el figyelmesen
ezt az összeszerelési útmutatót,
mert a helytelen összeszerelésből
a dódó hibákért nem vállalunk felelősséget!

SK – Prosíme, dobre prečítajte si tento návod na montáž,
pretože nepreberáme žiadne ručenie za chyby,
ktoré vzniknú na základe chybnej montáže!

RO – Vă rugăm să cititi cu atenție aceste instructiuni
de montaj deoarece nu preluăm garanția pentru defecte
ce apar datorită unui montaj incorect!

RUS – Пожалуйста, внимательно ознакомьтесь ù
с данной инструкцией по монтажу, поскольку мы не
несем ответственности за ошибки, причиной которых
является неправильный монтаж.

TU – İlkonce kullanma klavuzunu iyi okkuyun,
yalnis montaj yapasaniz bunun sorumlusu biz degiliz.

ES – Se ruega leer con atención las instrucciones
de montaje debido a que declinamos cualquier
responsabilidad
por defectos derivados de un montaje erróneo.

LC S.p.A
Via del Piano s.n
61030 Isola del Piano (PU)
Italia
<http://www.lcmobili.com/>



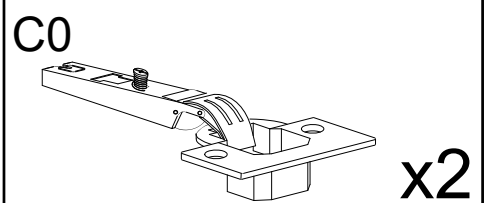
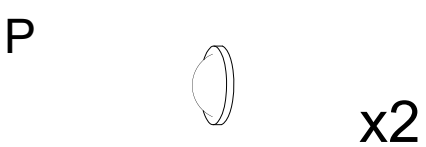
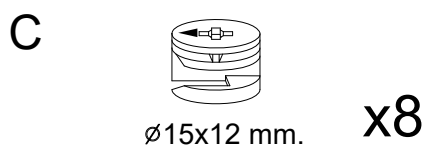
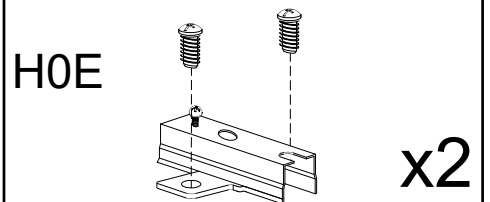
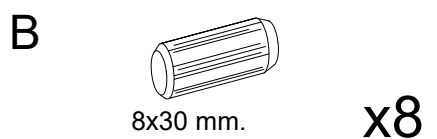
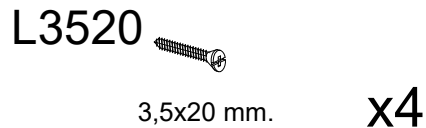
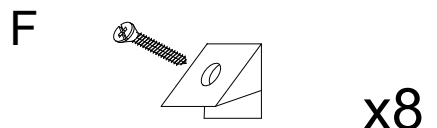
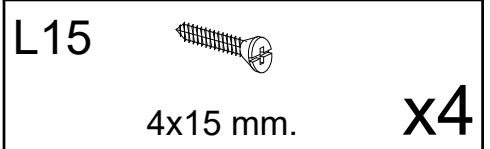
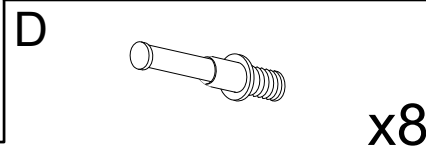
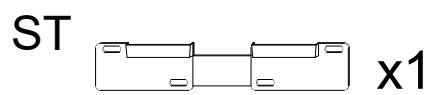
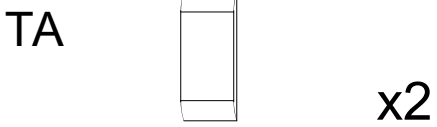
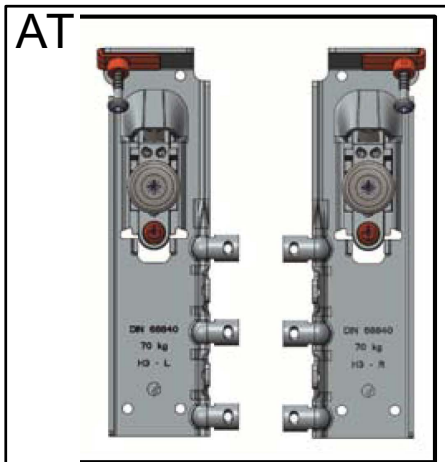
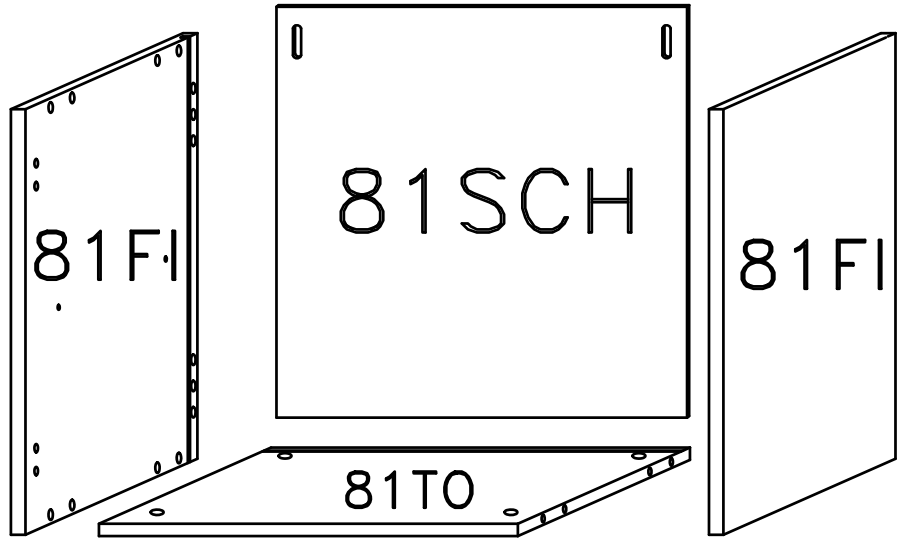
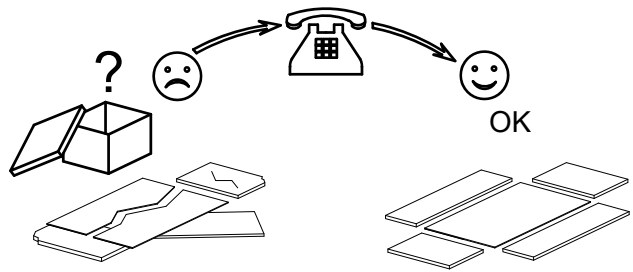
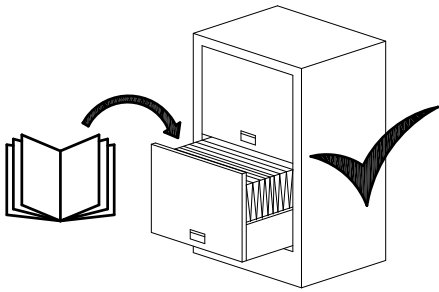
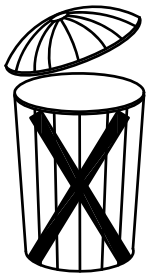

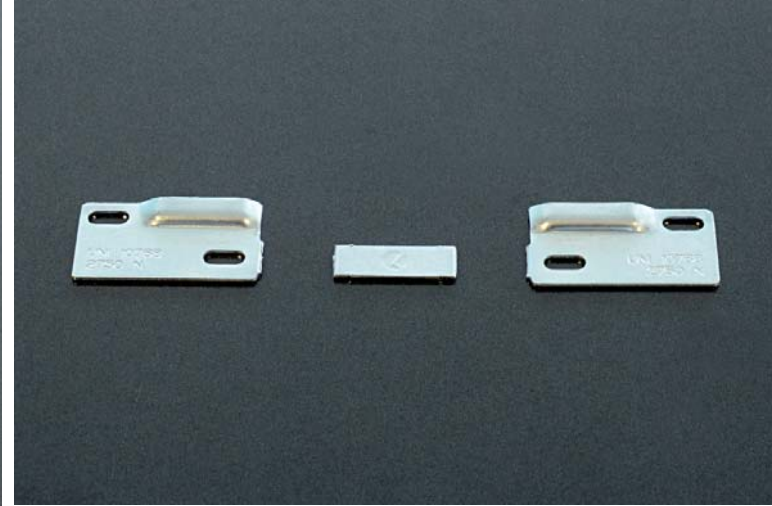
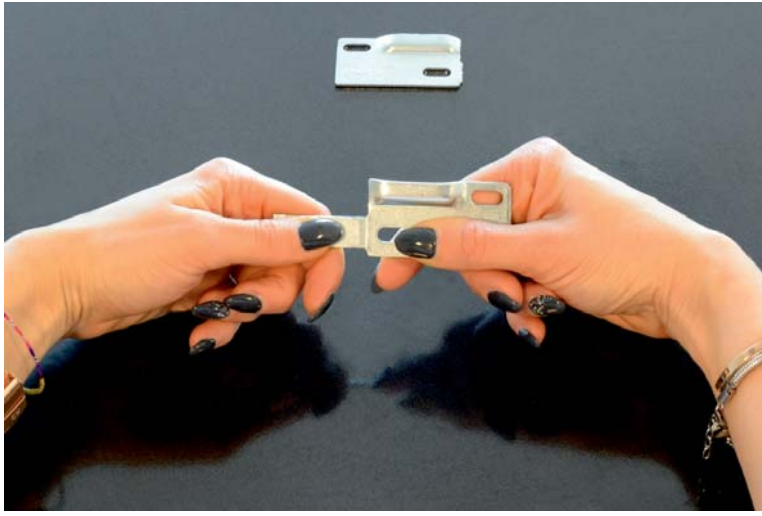
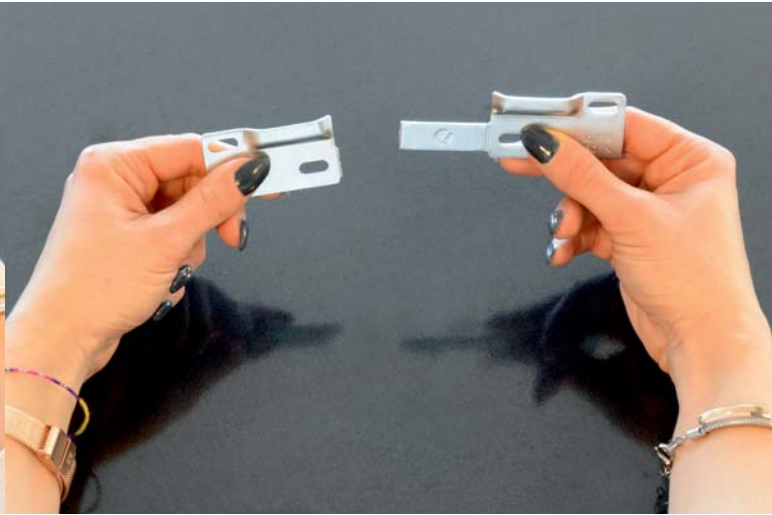
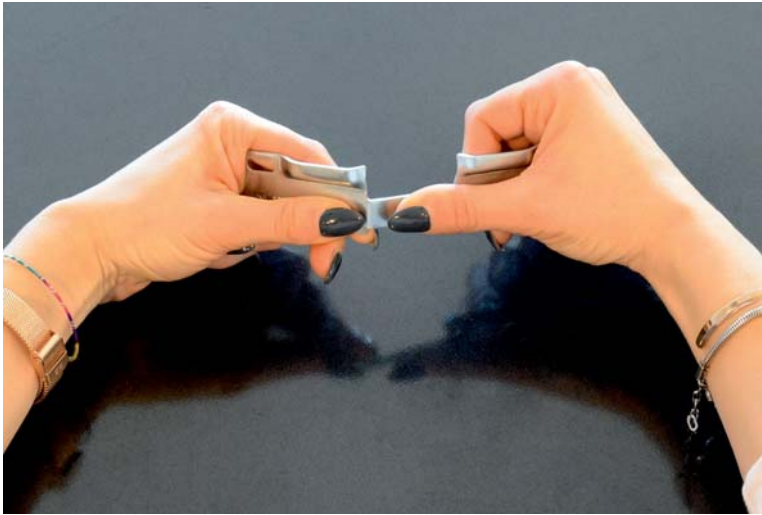
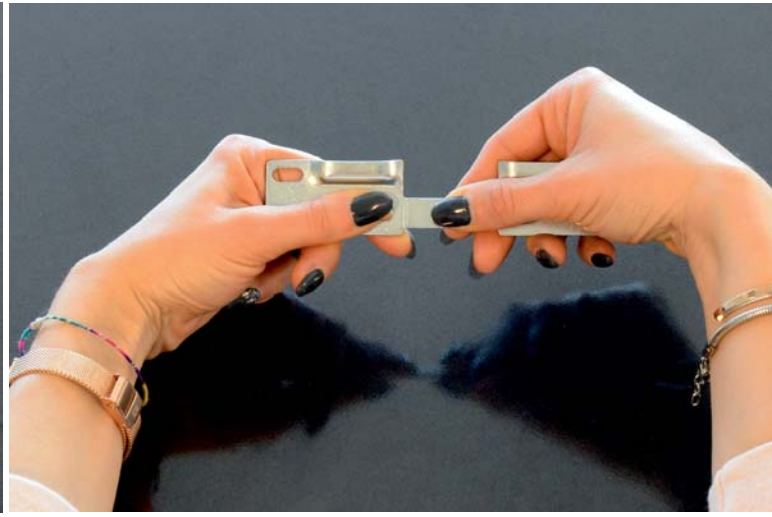
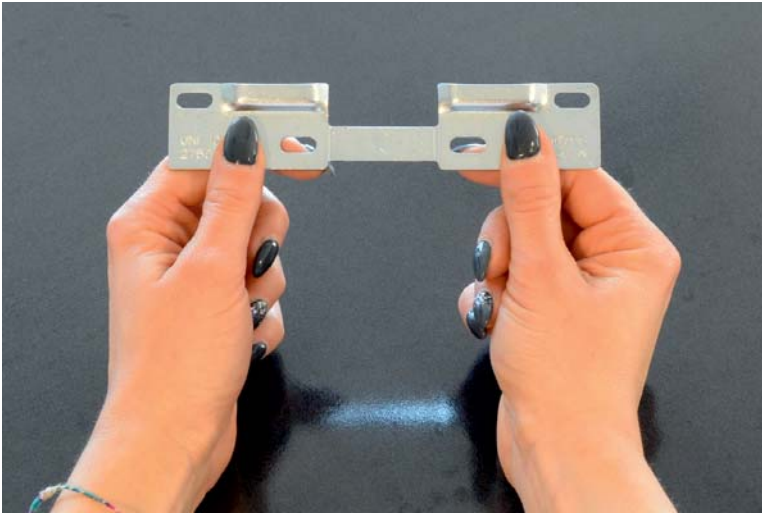

1

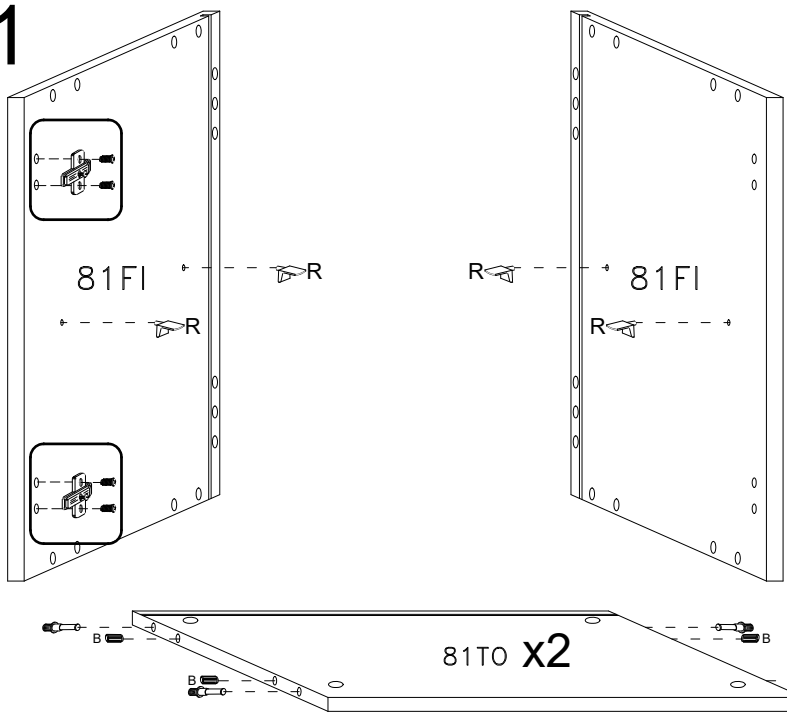

B



8x30 mm.

x8

C



ø16 mm.

x8

D

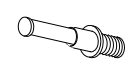

x8

H0E



x2

R



x4

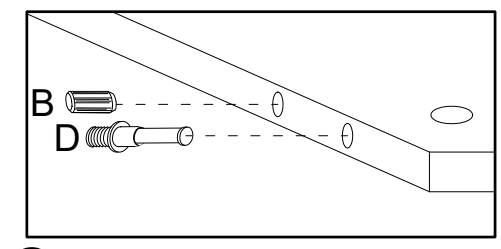
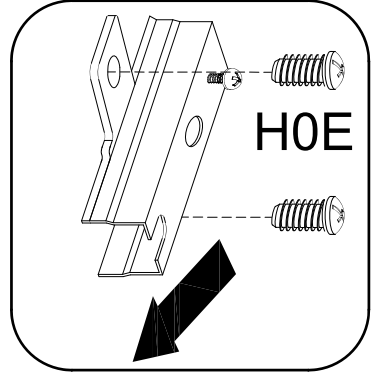

2

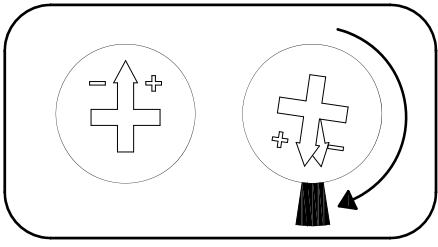
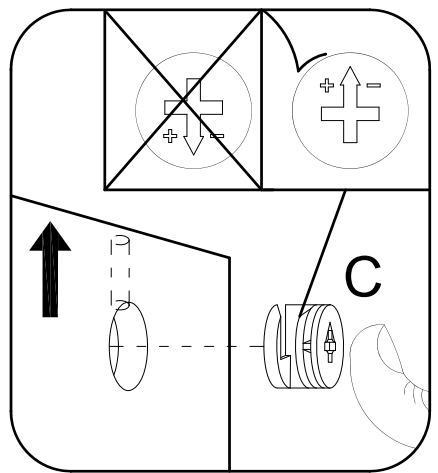
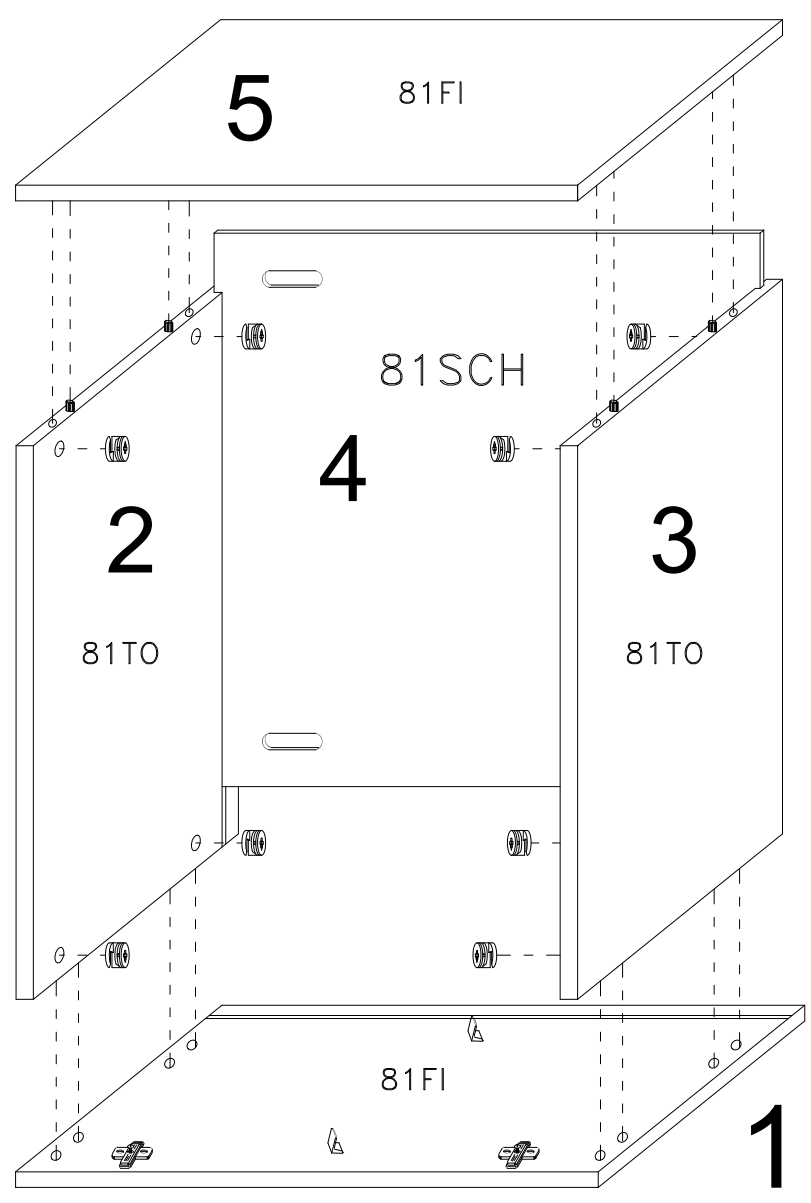

3

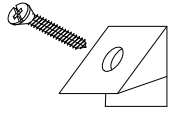
F  x8

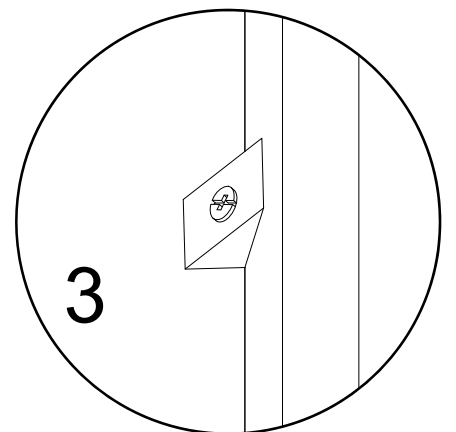
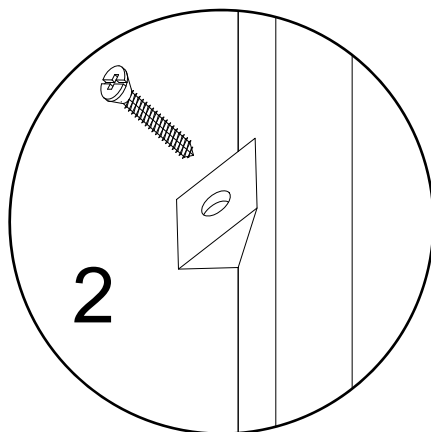
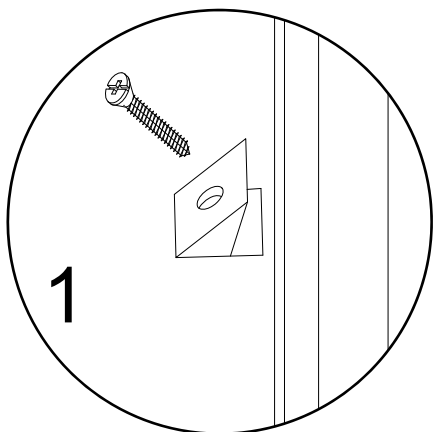
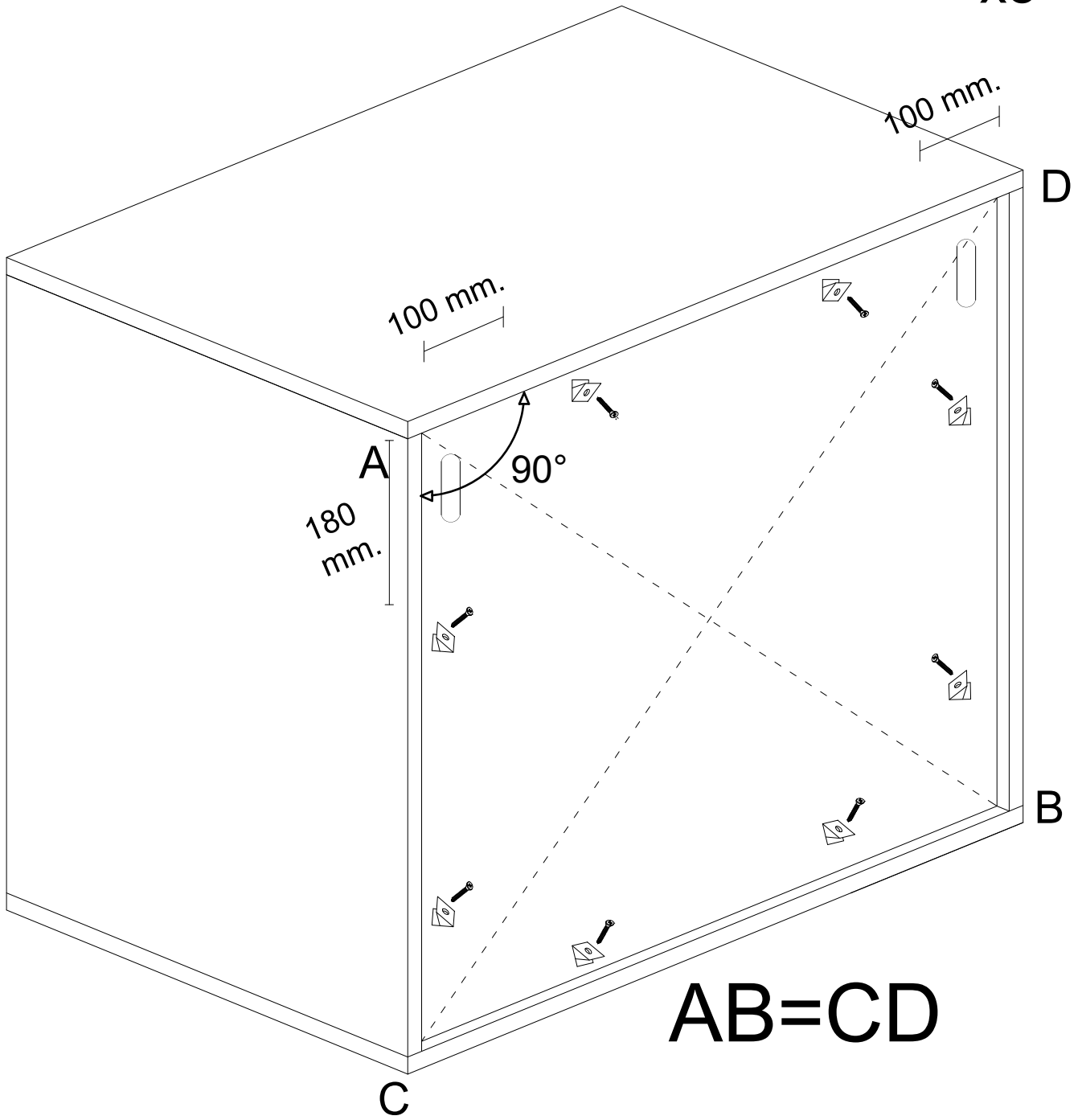

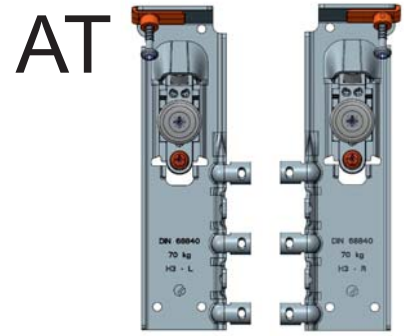
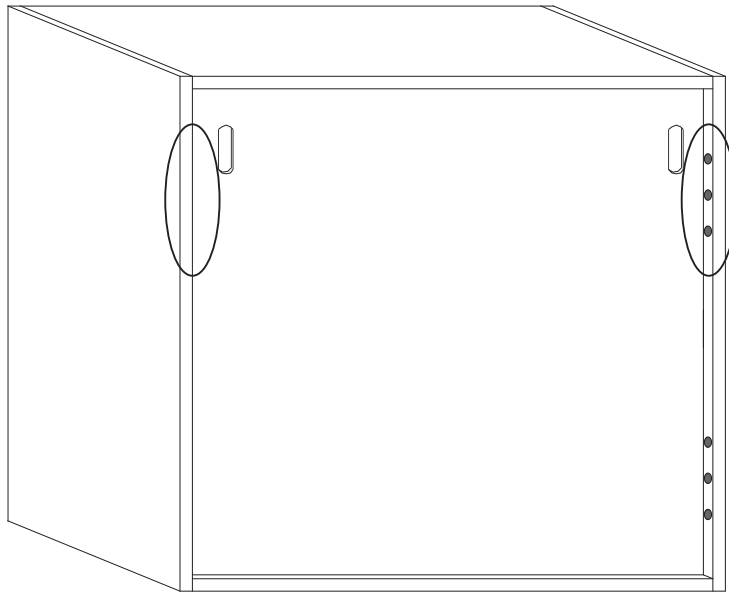

L3520

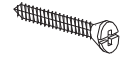

3,5x20 mm. **x4**

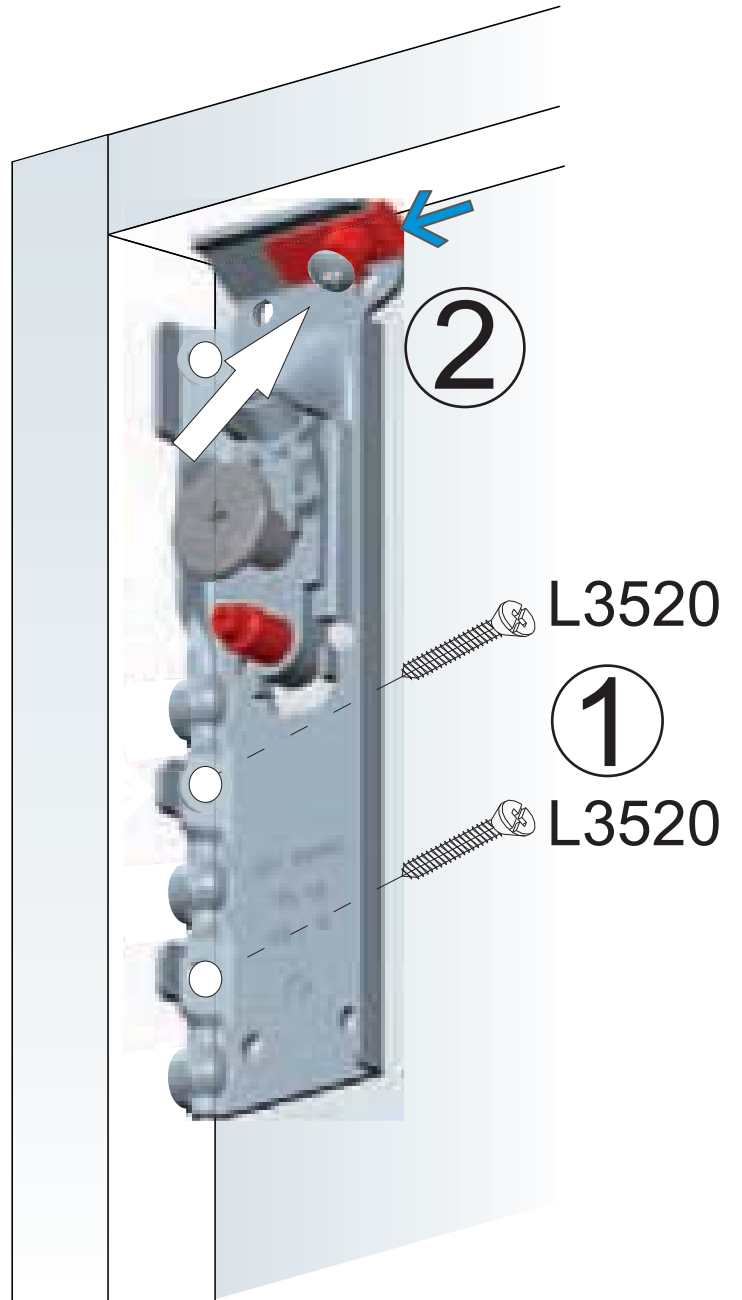
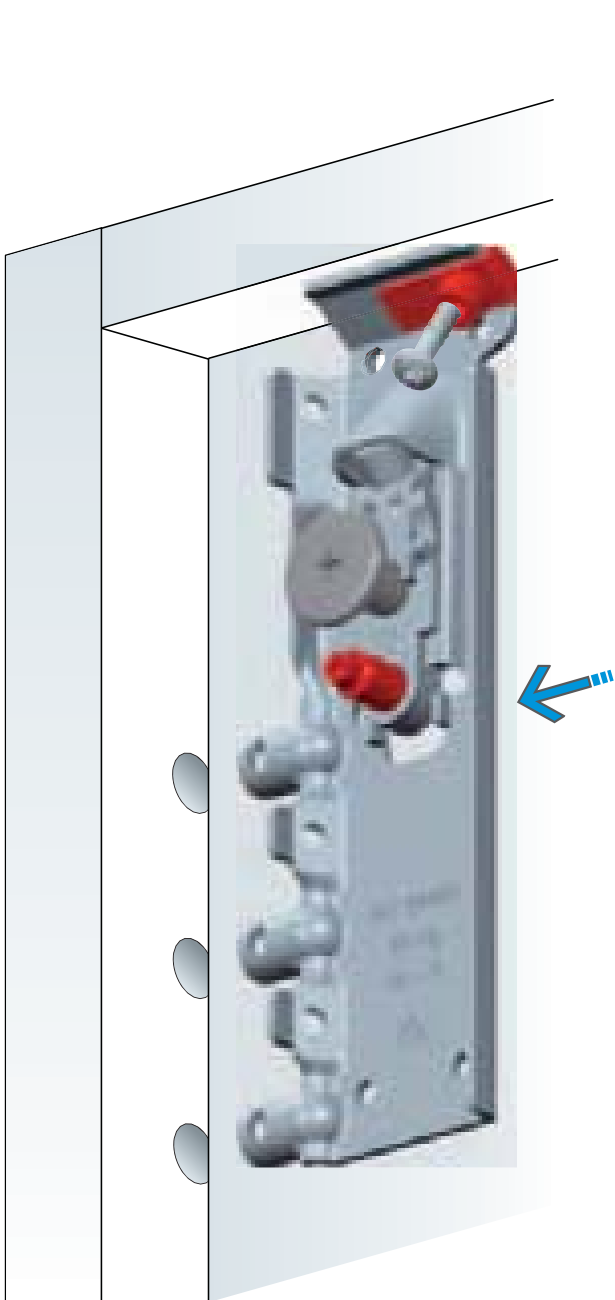



ST



x1

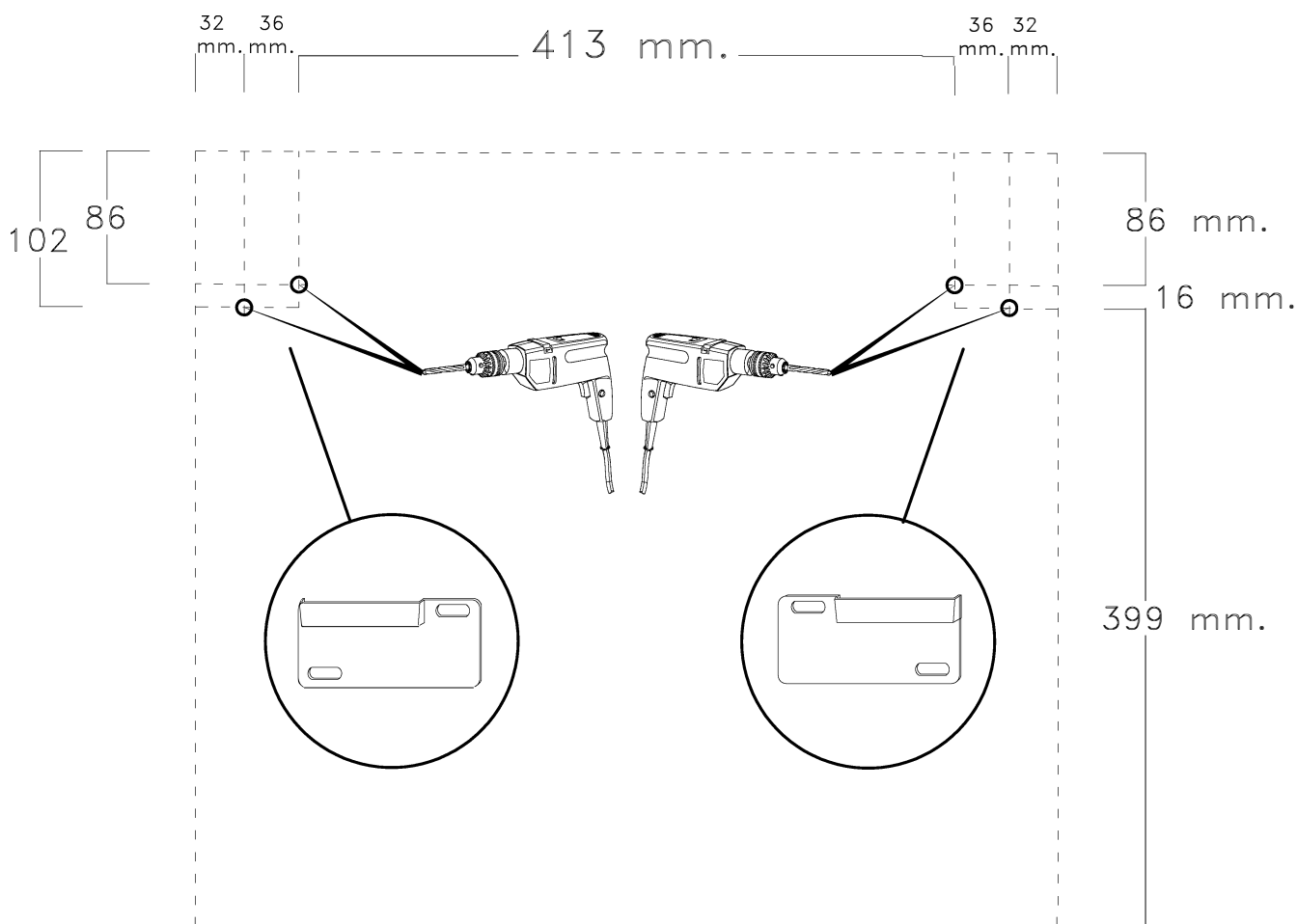

Gentile Cliente

Il montaggio dei pensili deve essere effettuato da personale competente. I tasselli di fissaggio non sono compresi nella ferramenta. Scegliere il tipo di tassello per il fissaggio più adatto alla tipologia di muro. Assicurarsi l'idoneità della parete per un sostegno sicuro del pensile.

Dear Customer,

The assembling of the hanging elements must be done by a competent staff. The wall plugs are not included in the hardware package. Choose the wall plugs more suitable to the type of the wall. Ensure the suitability of the wall for a secure support of the hanging element.

Sehr geehrter Kunde, die Montage der Hängeelemente muss von Fachpersonal ausgeführt werden!

Bitte verwenden Sie eigene Dübel, die der Beschaffenheit der Wand entsprechen. Zu Ihrer eigenen Sicherheit legen wir dem Beschlagbeutel keine Dübel bei.

Cher client, les éléments muraux ne peuvent être installés que par du personnel qualifié !

Veillez utiliser vos propres ancrages adaptés à la nature du mur. Pour votre sécurité, nous n'incluons pas de chevilles dans le matériel.

Estimado cliente, el montaje de los muebles colgados en la pared debe ser realizado por personal competente. Los tacos de fijación no están incluidos en la bolsa de herrajes. Elija el tipo de anclaje de fijación que mejor se adapte al tipo de pared. Asegúrese de que la pared sea adecuada para un soporte seguro del mueble colgado en la pared.

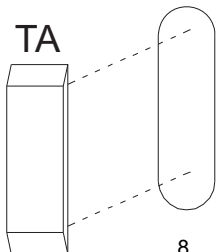
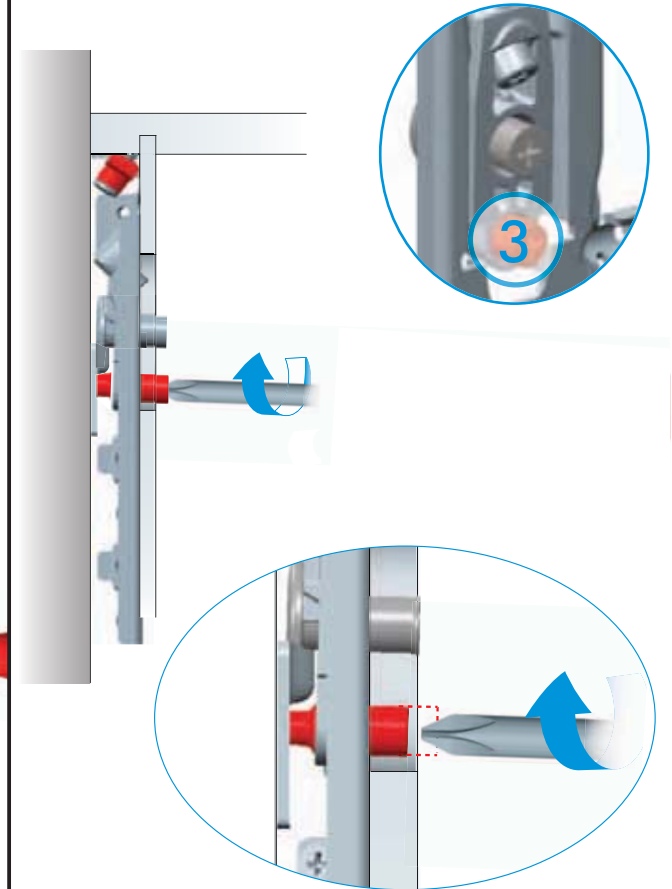
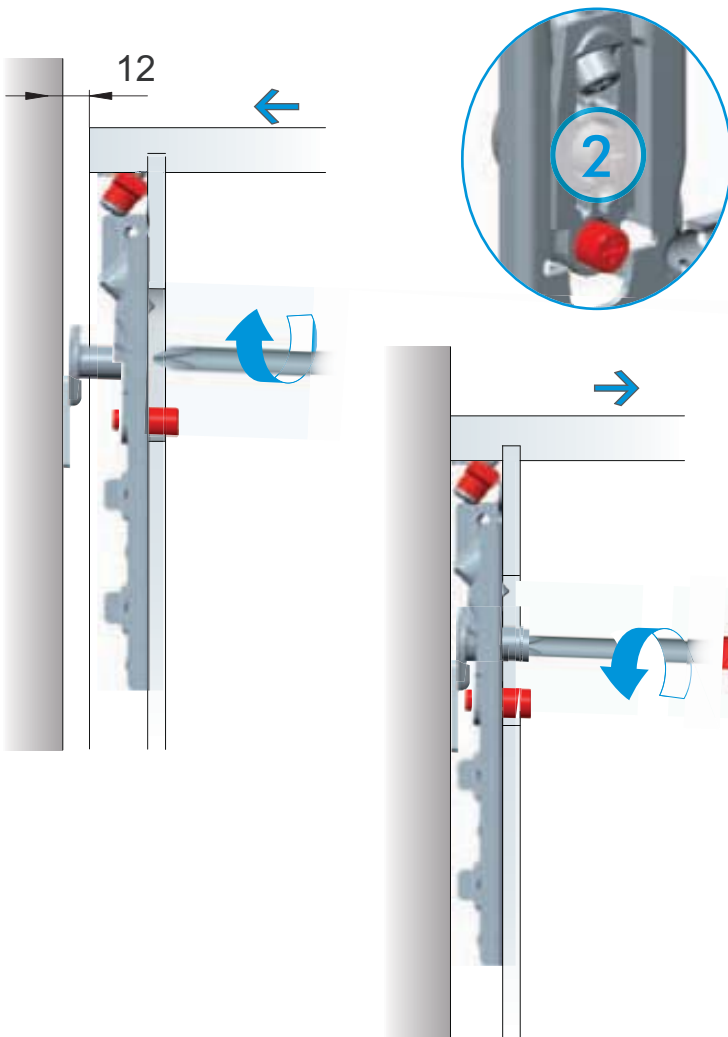
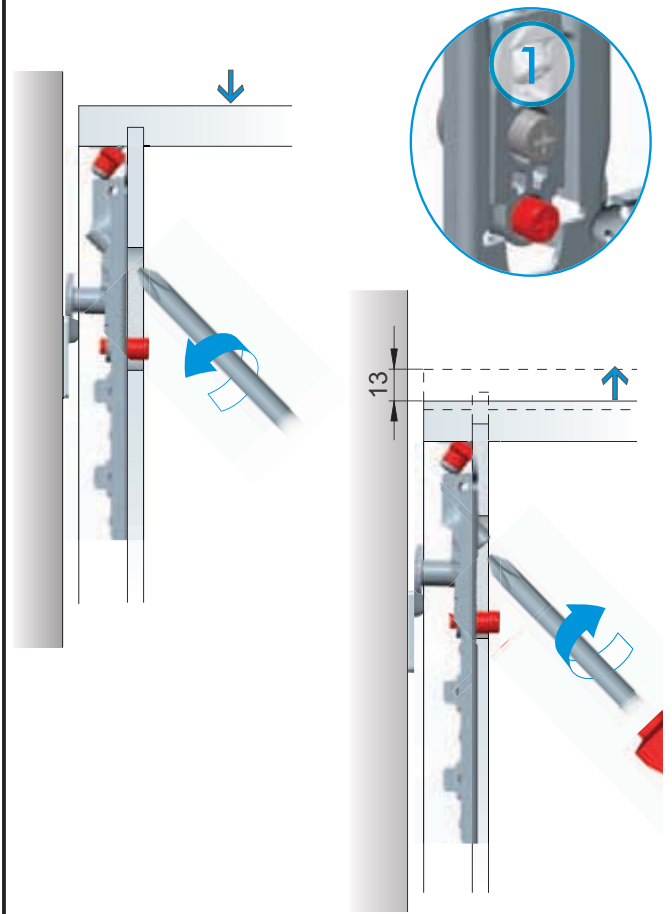
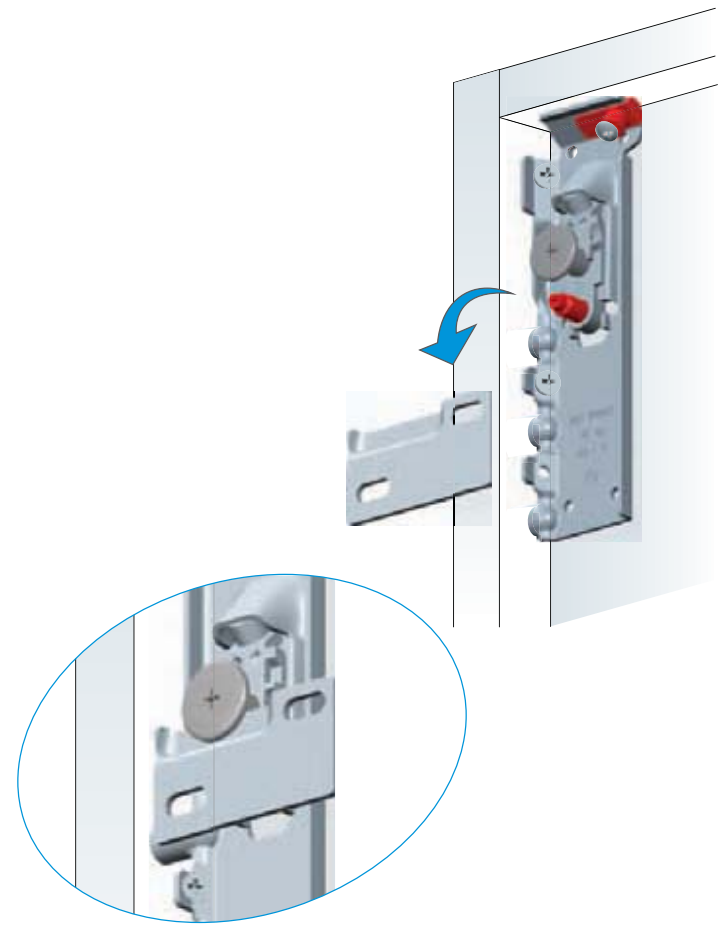

4

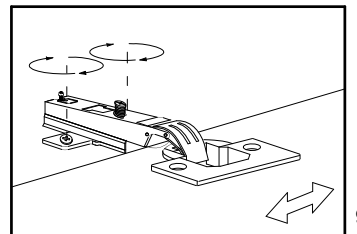
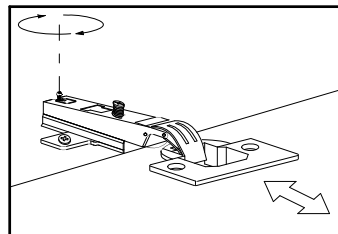
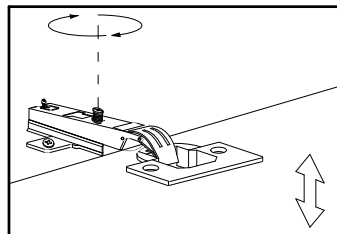
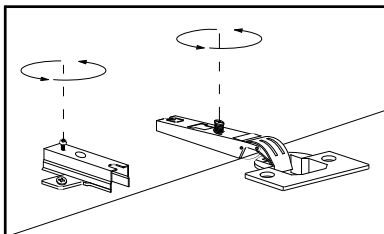
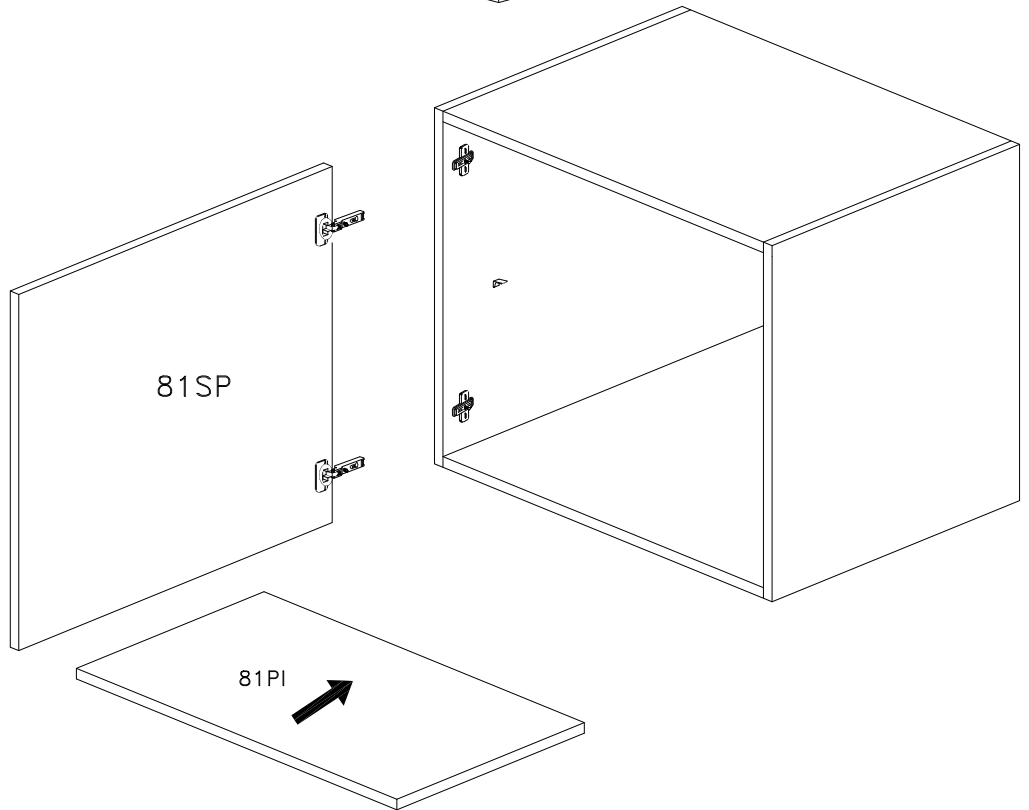
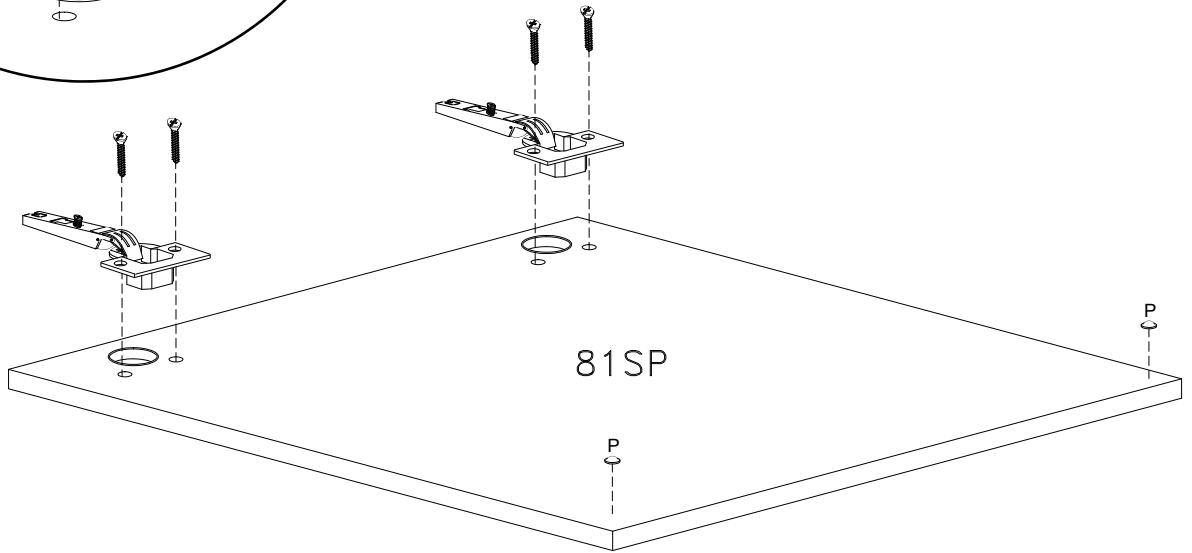
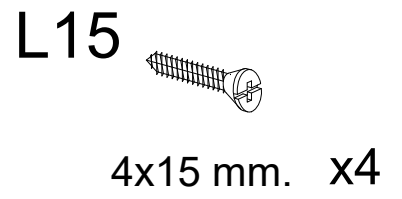
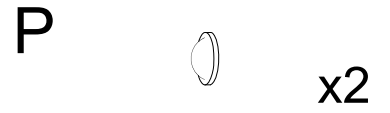
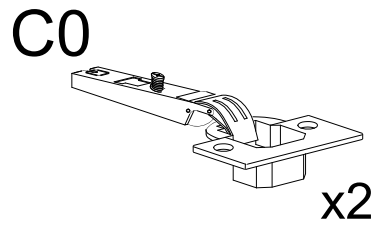
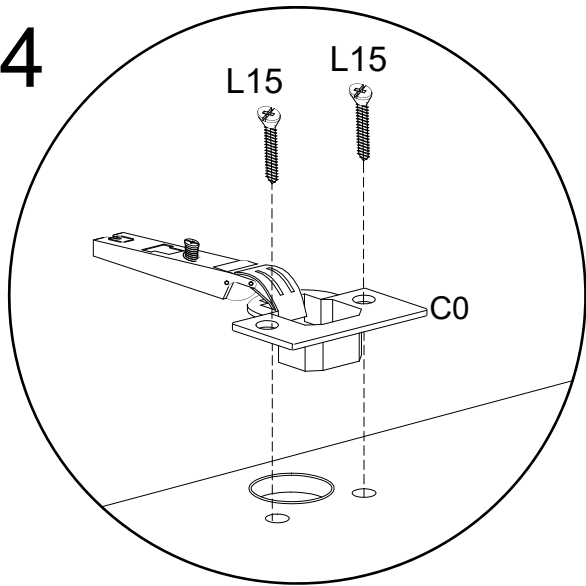

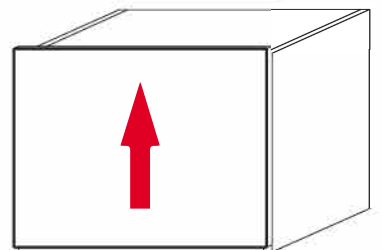
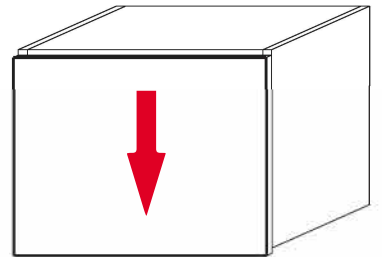
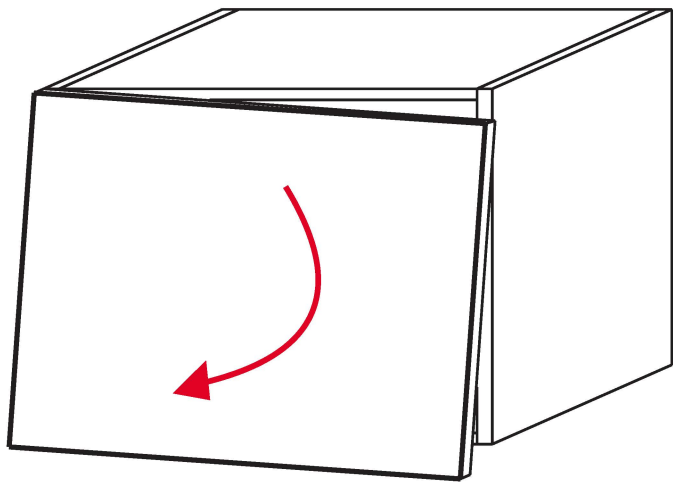
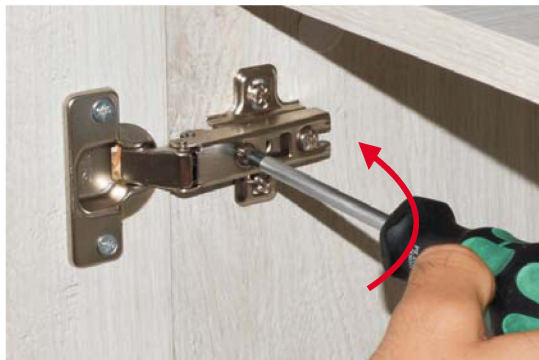
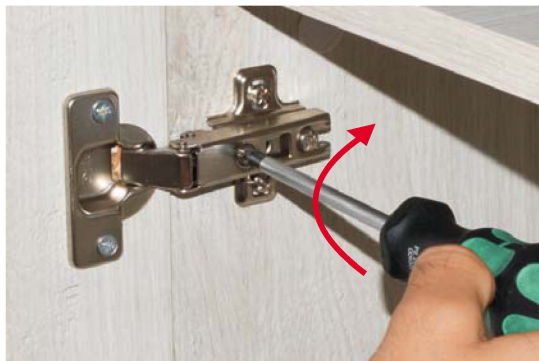
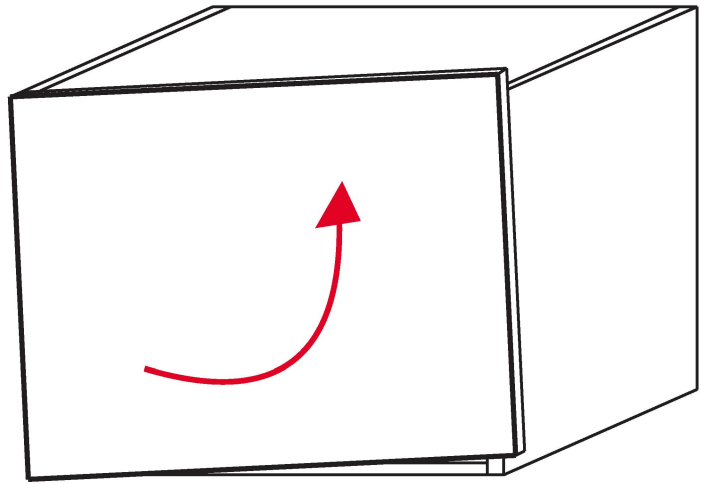
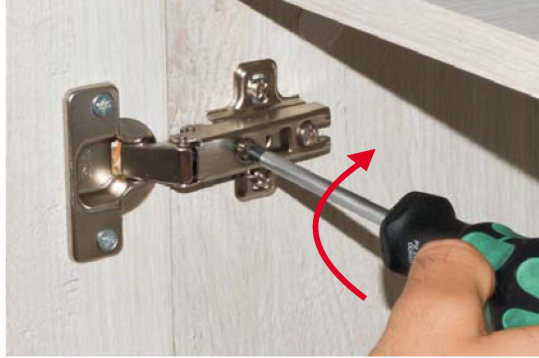
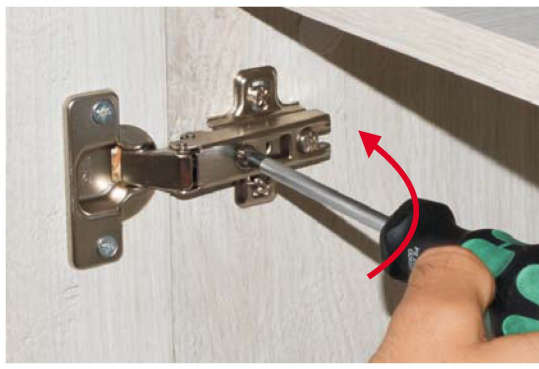

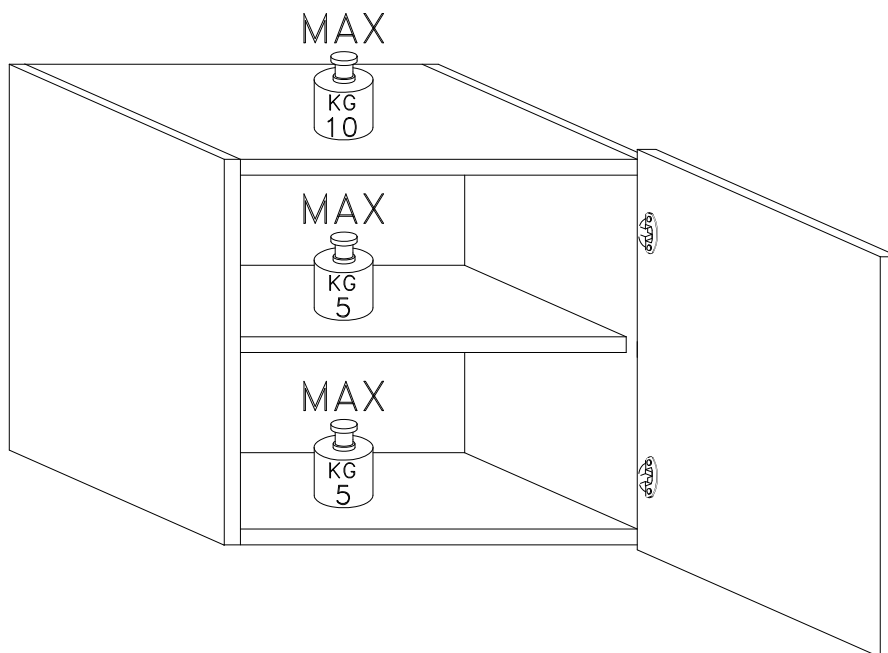
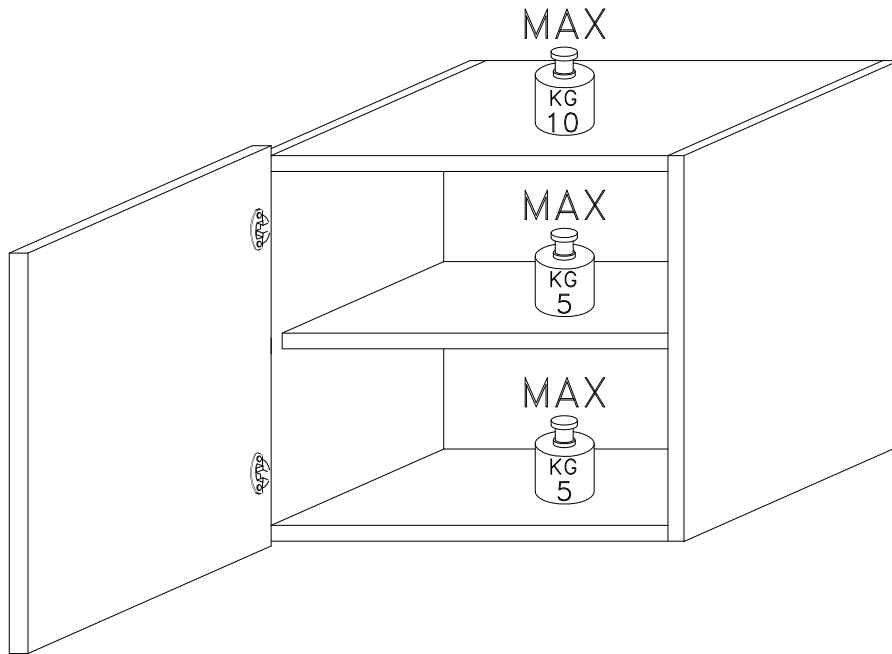

Montageanweisung / Installation instructions / Instruction de montage / Istruzioni di montaggio
montagehandleiding / Instrukcja montazu / Montaj talimatlar / Osszeszerelési útmutató / Nàvod k montázi /
Nàvod na montaz / Instructiune de montaj / Инструкция по монтажу / Montaj talimatina / Monteringsanvisningar
Upute za montažu / Instrucciones de Montaje / Navodila za montažo

INFINITY 2.0

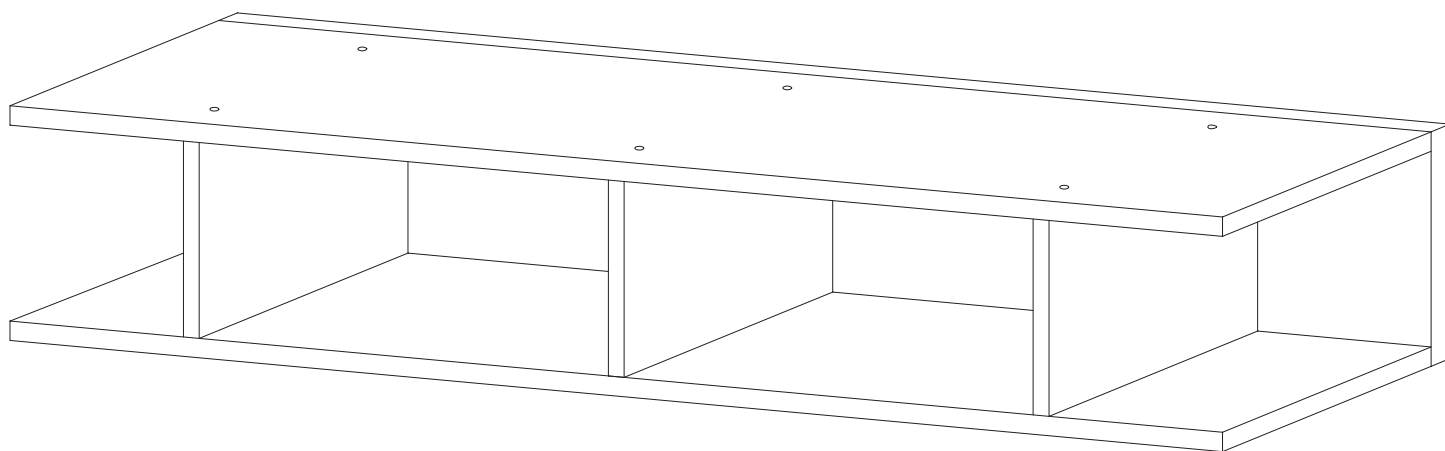
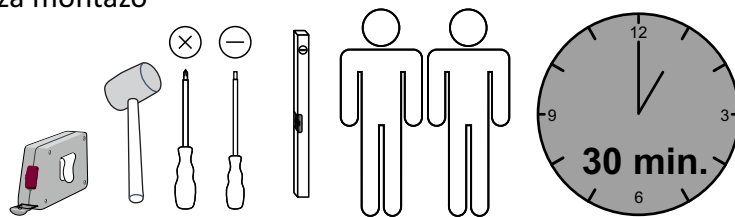

LC S.p.A
Via del Piano s.n
61030 Isola del Piano (PU)
Italia
<http://www.lcmobili.com/>

D – bitte lesen sie diese montageanleitung gut durch,
Da wir für fehler, die durch falsche montage entstehen,
Keine haftung übernehmen!

Gb – please read these installation instructions
Through carefully as we cannot accept any liability
For faults occurring as a result of incorrect installation!

Cz – přečtete si prosim pozorně tento návod k montáži,
Aby jste předešli chybám vzniklých špatnou montáží,
Za které neručíme!

F – veuillez lire attentivement cette notice de montage,
Car nous déclinons toute responsabilité en cas d'erreurs
Découlant d'un montage erroné !

I – prego leggere attentamente le istruzioni per il montaggio,
Poiché decliniamo qualsiasi responsabilità
Per difetti derivanti da montaggio errato.

S - läs monteringsanvisningarna noggrant.
Vi avsåger oss allt ansvar för defekter som
Uppstår p.g.a. Felaktig montering.

Hr – pažljivo pročitajte upute za montažu,
Jer otklanjamo svaku odgovornost za pogreške
Nastale uslijed pogrešne montaže.

Slo – prosimo, da pozorno preberete navodila za montažo,
Saj zavračamo vsakršno odgovornost za napake,
Ki bi nastale zaradi napačne montaže.

Nl – leest u alstublieft deze montagehandleiding goed door,
Voor fouten door verkeerde montage zijn wij niet verantwoordelijk.

Pl – prosze uwaznie zapoznac sie z instrukcja montazu,
Poniewaz nie ponosimy odpowiedzialnosci za niewlasciwy montaz.

Hu – Kérjük, olvassa el figyelmesen
ezt az összeszerelési útmutatót,
mert a helytelen összeszerelésből
a dódó hibákért nem vállalunk felelősséget!

SK – Prosime, dobre prečítajte si tento návod na montáž,
pretože nepreberáme žiadne ručenie za chyby,
ktoré vzniknú na základe chybnej montáže!

RO – Vă rugăm să cititi cu atenție aceste instructiuni
de montaj deoarece nu preluăm garantia pentru defecte
ce apar datorită unui montaj incorect!

RUS – Пожалуйста, внимательно ознакомьтесь ù
с данной инструкцией по монтажу, поскольку мы не
несем ответственности за ошибки, причиной которых
является неправильный монтаж.

TU – İlkonce kullanma klavuzunu iyi okuyun,
yalnis montaj yapasaniz bunun sorumlusu biz degiliz.

ES – Se ruega leer con atención las instrucciones
de montaje deibido a que declinamos cualquier
responsabilidad
por defectos derivados de un montaje erróneo.

43SCH

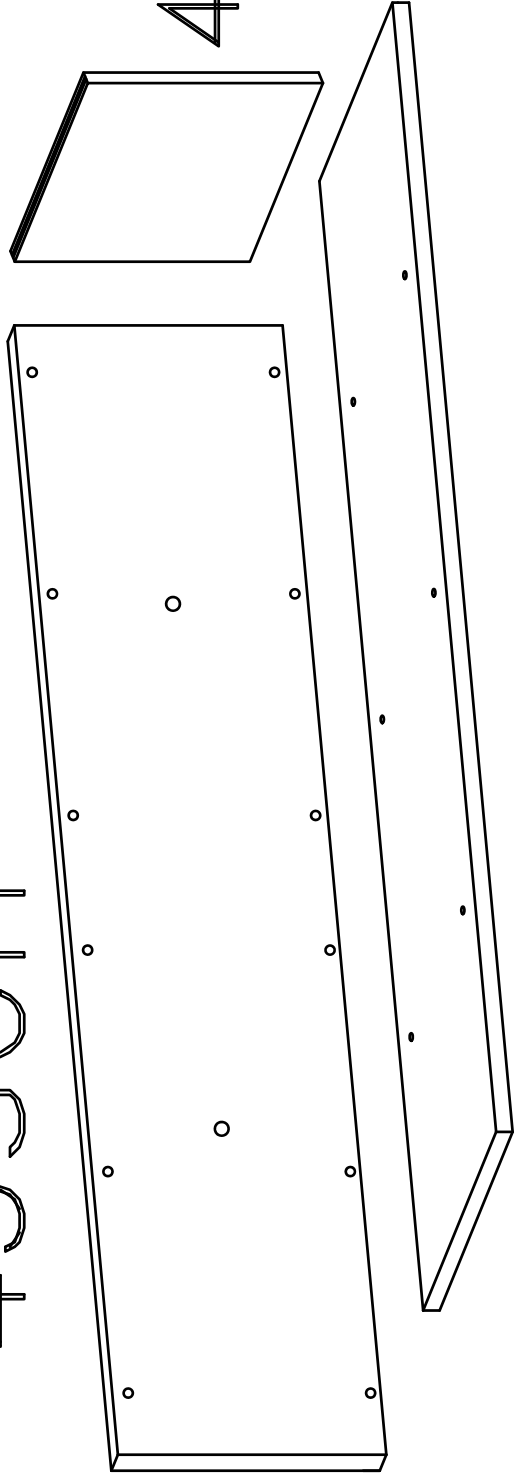

43TR x3

43MEN x2

L3545

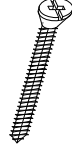

x24

3,5x45 mm.

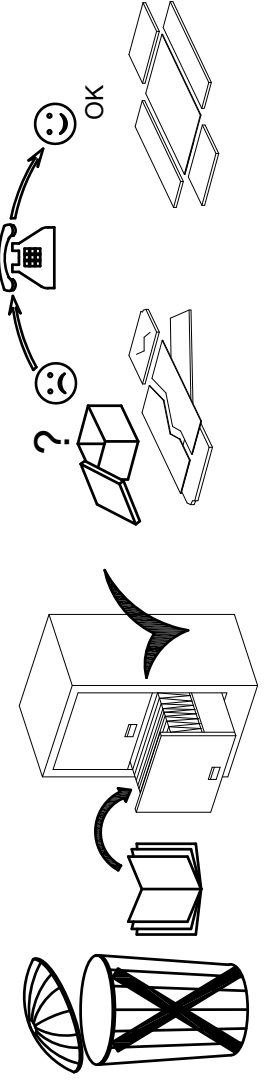

N-8

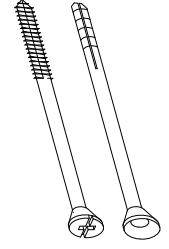

80 mm.

x2

1

L3545



3,5x45 mm.

X12

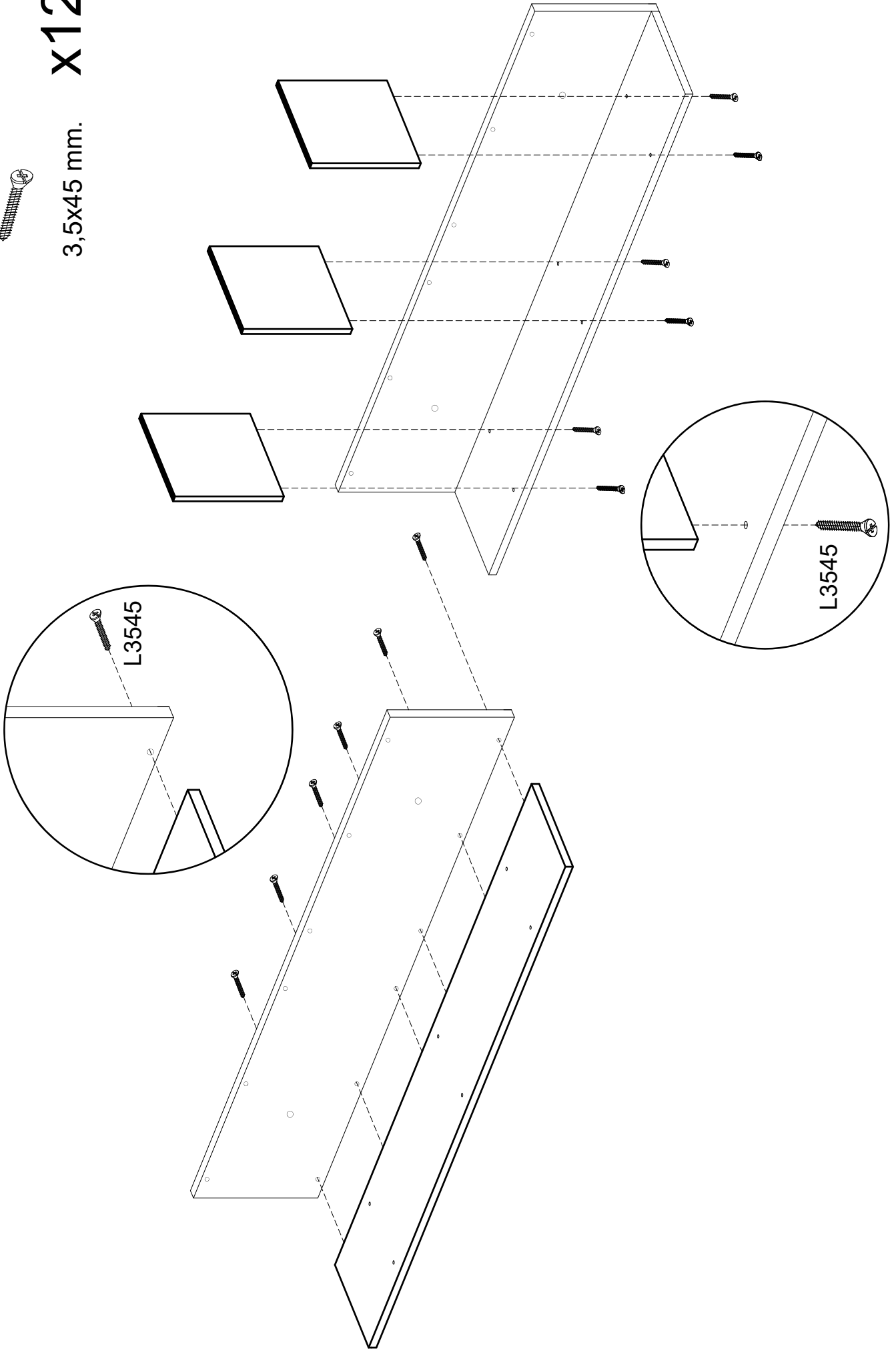

2

L3545



3,5x45 mm.
X12

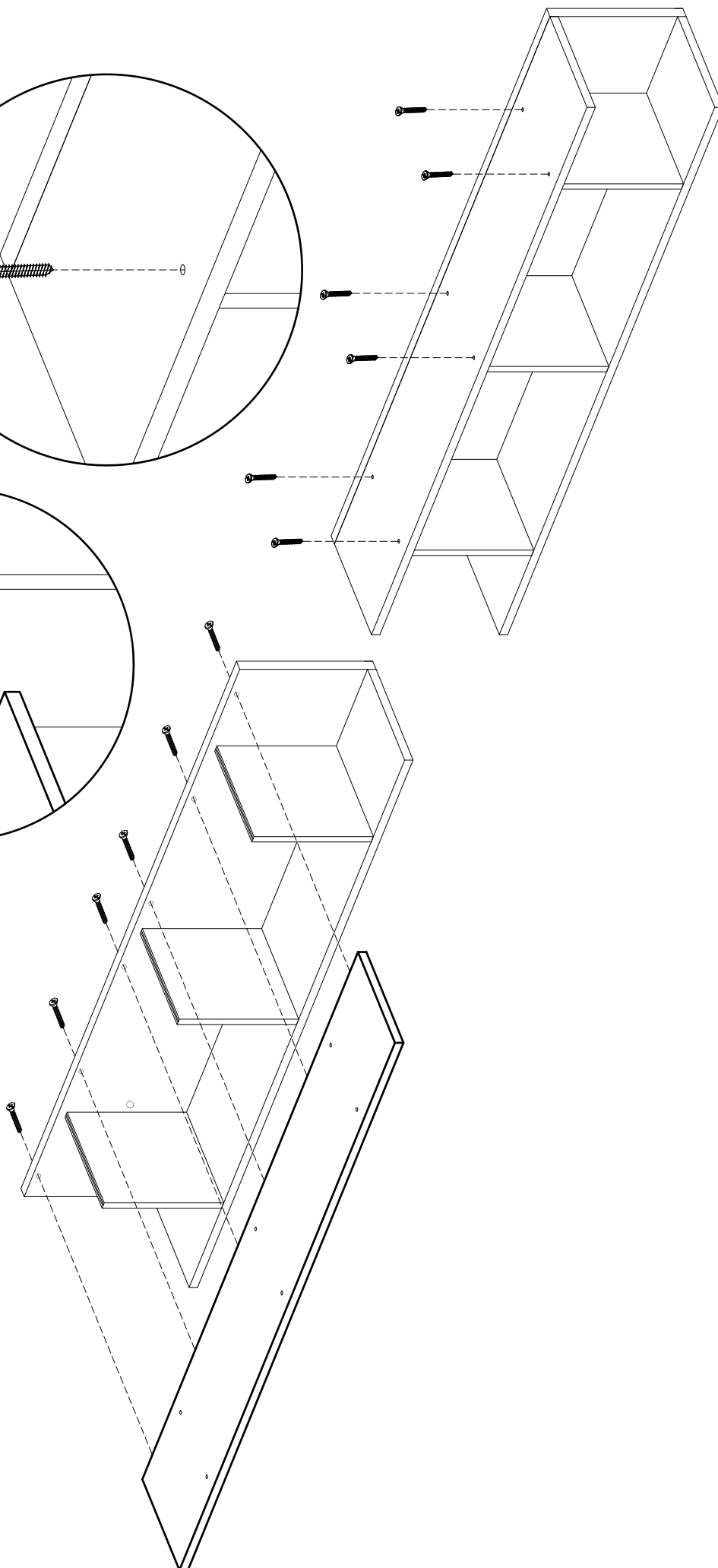
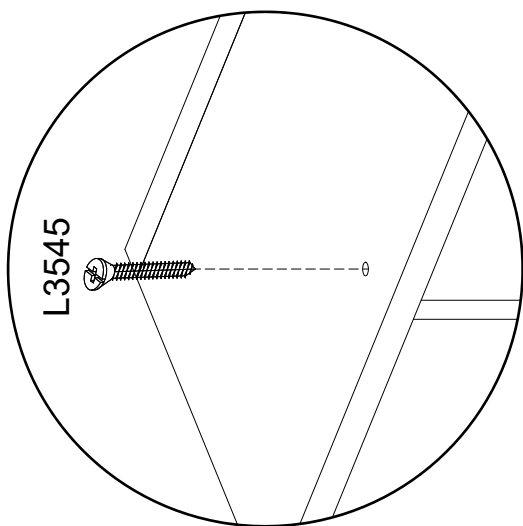
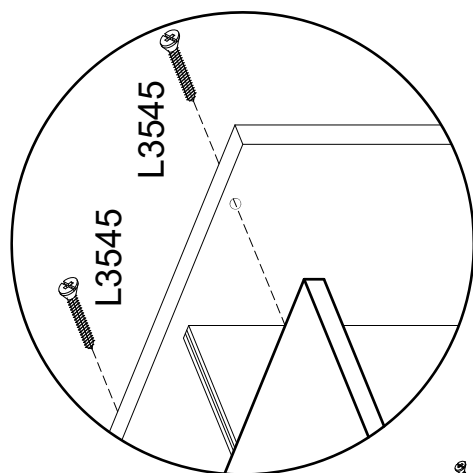

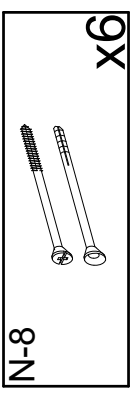

880mm. 250mm.

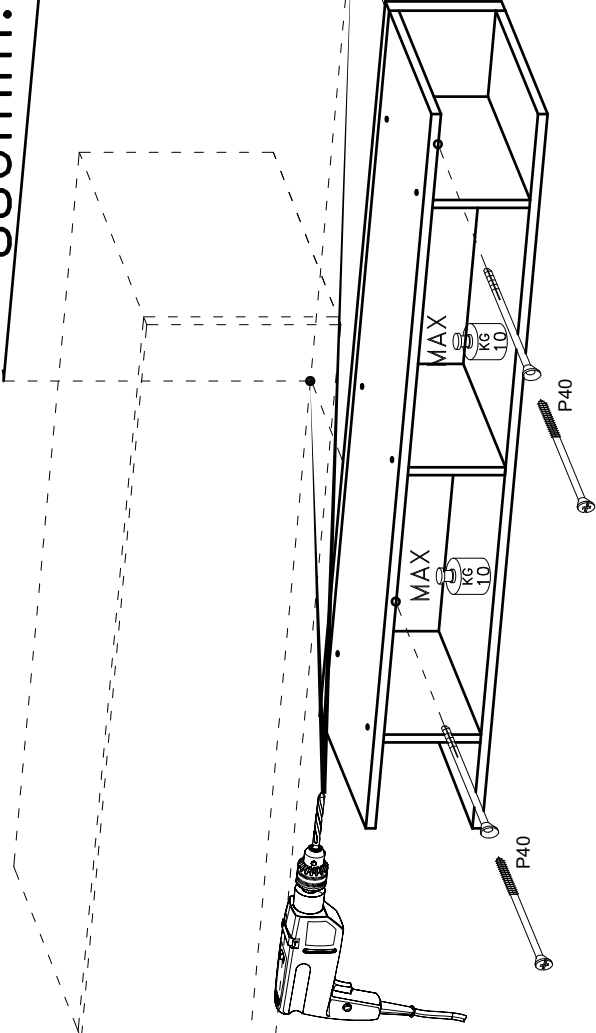
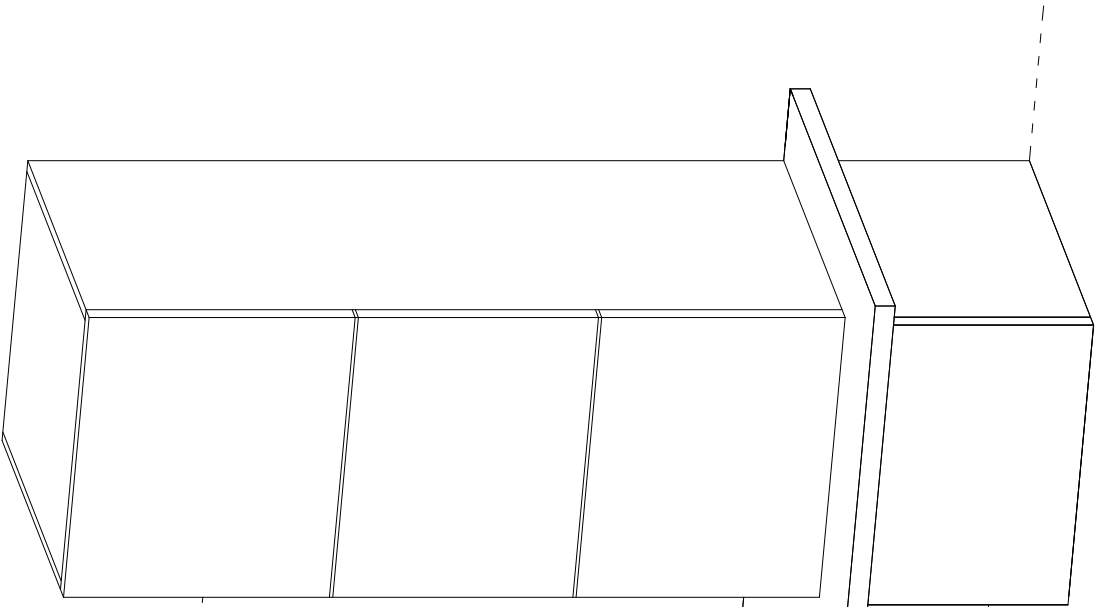

ø8 mm.

1564 mm.

