

F

Instructions d'utilisation

IMPORTANT - LIRE ATTENTIVEMENT - A CONSERVER POUR REFERENCE ULTERIEURE

1. Utiliser les outils indiqués sur la notice de montage et suivre les instructions d'assemblage.
2. Il convient que tous les dispositifs d'assemblage soient toujours convenablement serrés et régulièrement vérifiés, ainsi que resserrés si nécessaire.
3. Le positionnement et le moyen d'accès au lit sont indiqués sur la notice de montage.
4. **Respecter l'épaisseur maximale du matelas, voir le marquage sur l'étiquette collé sur le lit.**
5. Taille du matelas recommandé 2000 x 1400; 2000x900 maximum.
L'épaisseur maximale du matelas conseillé est 220mm.
6. Il convient de ne pas utiliser le lit surélevé lorsqu'une partie de la structure manque ou est cassée
7. Les lits surélevés ne conviennent pas aux enfants de moins de 6 ans, en raison des risques de blessures dues aux chutes
8. Attention aux articles tels que des cordes, des ficelles, des cordons, des harnais et des ceintures attachés ou accrochés sur un lit superposé ou surélevé afin d'éviter aux enfants de s'étrangler.
9. Avertissement «Les enfant peuvent se retrouver piégés entre le lit et le mur. Pour éviter le risque de blessure grave la distance entre la barrière de sécurité supérieure et le mur ne doit pas excéder 75 mm ou doit être d'au moins 230 mm»
10. Conforme à la norme européenne EN747-1 de 2015.
11. Ne jamais laisser des enfants sans un minimum de surveillance
12. Aucun jeu brutal ne doit être permis dans et sous le lit haut.
13. Il est interdit d'avoir plus d'une personne dans le lit haut.
14. Ne pas permettre aux enfants de se basculer ou de sauter sur ou sous le lit.
15. Utiliser toujours l'échelle pour monter ou descendre du lit haut.
16. Ne pas remplacer les pièces originales par des substitutions. Obtenir les pièces de rechange du magasin ou du fabricant.
17. L'utilisation d'une veilleuse de nuit peut procurer plus de sécurité à l'enfant couchant dans le lit haut.

GB

Instructions for use

IMPORTANT - PLEASE READ CAREFULLY - KEEP FOR FUTURE REFERENCE

1. Use the tools indicated on the assembly leaflet and follow the instructions.
2. All assembly components must always be tightened properly. Check regularly and retighten if necessary.
3. The positioning and means of access to the bed are indicated on the assembly leaflet.
4. **Do not exceed the maximum mattress thickness as the dotted line sticker indicated on bunk bed.**
5. Maximum recommended mattress size: 2000 x 1400; 2000x900.
The maximum mattress height is 220mm.
6. The high sleeper must not be used if a part of the structure is missing or broken.
7. High sleepers are not suited to children below the age of 6 years due to the risk of injury in the event of a fall.
8. Do not attach or suspend items such as ropes, strings, cords, harnesses and belts on a bunk bed or high sleeper to avoid the possibility of strangulation.
9. Warning: Children may become trapped between the bed and the wall. To avoid the risk of serious injury, the distance between the top safety barrier and the wall must not exceed 75 mm or must be at least 230 mm.
10. Compliant with European Standard EN 747-1 of 2015.
11. Never leave children without a minimum of supervision.
12. Children must not be allowed to play roughly on or under the top bunk.
13. It is forbidden to have more than one person in the top bunk.
14. Do not allow children to swing or jump on or under the bed.
15. Always use the ladder to climb up to and down from the top bunk.
16. Do not replace original parts with substitutes. Spare parts must be obtained from the store or manufacturer.
17. Use of a night-light will improve safety for a child sleeping in the top bunk.

D**BENUTZUNGSHINWEISE****WICHTIG - AUFMERKSAM LESEN - FÜR EINE SPÄTERE EINSICHT AUFBEWAHREN**







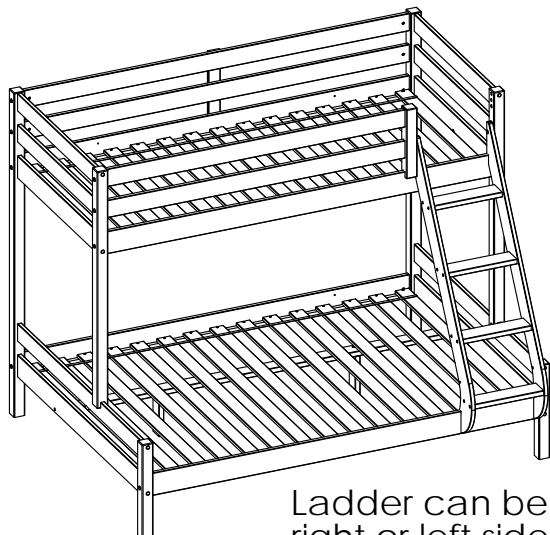
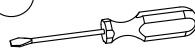
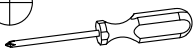
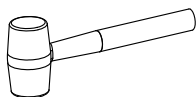
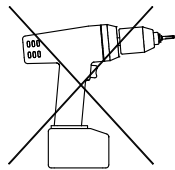
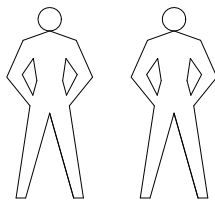
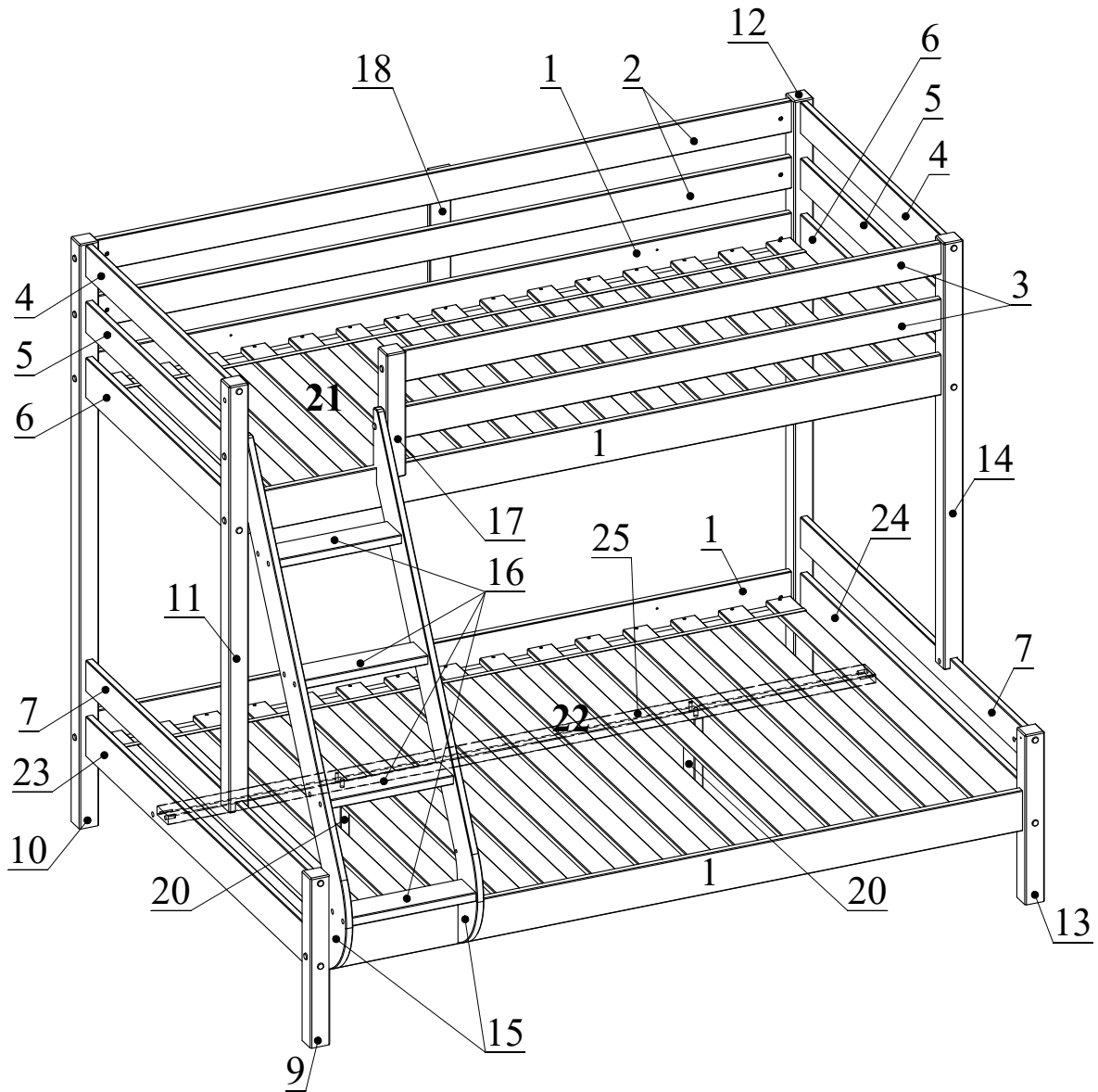









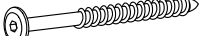



1. Die in der Montage Anleitung angeführten Werkzeuge benutzen, die Montagehinweise beachten.
2. Alle Elemente müssen korrekt verbunden und angezogen (notfalls nachziehen) sein und regelmäßig überprüft werden.
3. Die Position und der Zugang zum Bett sind in der Montageanleitung aufgeführt.
4. **Die maximale Stärke der Matratze einhalten, siehe Angaben auf das Etikett die auf das Bett geklebt ist.**
5. Empfohlene Abmessungen der zu Matratze 2000 x 1400; 2000x900 maximal.
Die max. Matratzenhöhe ist 220mm.
6. Das Etagenbett darf nicht benutzt werden wenn die Struktur oder ein Teil der Struktur fehlt oder beschädigt ist.
7. Die Etagenbetten sind nicht für Kinder unter 6 Jahren geeignet (Verletzungs- und Unfallgefahr)
8. Vorsicht ist weiterhin geboten mit am Etagenbett befestigten Seilen, Kordeln, Bändern, oder Sicherheitsgeschirr, hier besteht Strangulierungsgefahr für Kinder.
9. Warnung «Kinder können sich zwischen dem Bett und der Wand eingeklemmt finden. Um Unfälle zu vermeiden, darf der Abstand zwischen der oberen Sicherheitsleiste und der Wand nicht mehr als 75 mm betragen oder muß wenigstens 230 mm betragen .
10. Entsprechend der europäischen Norm NF EN747-1 von 2015
11. Kinder niemals ohne ein Minimum von Aufsicht lassen.
12. Brutale Spiele dürfen in oder auf dem oberen Bett nicht zugelassen werden.
13. Im oberen Bett darf nur eine Person schlafen.
14. Die Kinder dürfen nicht auf das Bett springen oder schaukeln.
15. Nur die Leiter zum Hinaufsteigen und Herabsteigen des oberen Bettes benutzen.
16. Nur Originalteile bei Reparaturen verwenden. Die Austauschteile nur im Fachhandel oder beim Hersteller einkaufen.
17. Die Benutzung einer kleinen Lampe kann dem Kind im oberen Bett ein Sicherheitsgefühl verleihen.

NL**Gebruiksaanwijzing****BELANGRIJK - AANDACHTIG LEZEN - BEWAREN VOOR LATERE NASLAG**

1. Gebruik het op de montagehandleiding aangegeven gereedschap en volg de assemblage-instructies.
2. Alle bevestigingsmiddelen van de assemblage moeten behoorlijk zijn vastgedraaid, regelmatig worden gecontroleerd en zonodig opnieuw worden aangehaald.
3. De plaatsing en de wijze van toegang tot het bed zijn op de montagehandleiding aangegeven.
4. **Houd u aan de maximale matrasdikte, zie de markering op het etiket dat op het bed gekleefd is.**
5. Aanbevolen matrasdikte: maximum 2000 x 1400; 2000x900.
De maximale matrashoogte bedraagt 220mm.
6. Het hoge bed moet niet gebruikt worden, wanneer een deel van de structuur ontbreekt of kapot is.
7. Hoge bedden zijn niet geschikt voor kinderen onder de 6 jaar, vanwege het gevaar van verwondingen door vallen.
8. Wees voorzichtig met dingen als koorden, touwtjes, snoeren, tuigjes en gordels die vastgemaakt zijn aan een hoog bed, om te voorkomen dat kinderen gekeeld worden en stikken.
9. Waarschuwing «Kinderen kunnen klem raken tussen het bed en de muur. Om ernstige verwondingen te voorkomen, moet de afstand tussen de bovenste veiligheidsstang en de muur niet meer zijn dan 75 mm of minstens 230 mm,»
10. Voldoet aan de Europese norm EN747-1 van 2015.
11. Laat kinderen nooit alleen zonder minimale bewaking
12. Verbied woeste spellen in en onder een verhoogd bed.
13. Er mag zich maar één persoon tegelijk in het hoge bed bevinden.
14. Laat kinderen niet wippen of springen in of onder het hoge bed.
15. Gebruik altijd de ladder om in en uit het hoge bed te klimmen.
16. Vervang de originele stukken niet door namaak. Betrek de vervangende onderdelen van uw Leverancier of van de fabrikant.
17. Het gebruik van een nachtlampje kan kinderen in een verhoogd bed een veilig gevoel geven.



Ladder can be fitted right or left side

A		10x40	x62	L		5x38	x1
B		7x30	x2	M		3,5x40	x60
C		7x50	x20	N		5x30	x6
D		6,3x90	x16	P		D15x18	x34
E		M6x70	x1	Q		D2,3x12	x1
F		M6x90	x15	R		D5x8	x2
G		M6x110	x1	S		D8x13	x2
H		M6x10x13	x16	T		D10x15	x2
J		M6x8x12x15	x1	Z		D4x13	x20
K		55/12,5x5	x2	W		4mm	x2

①

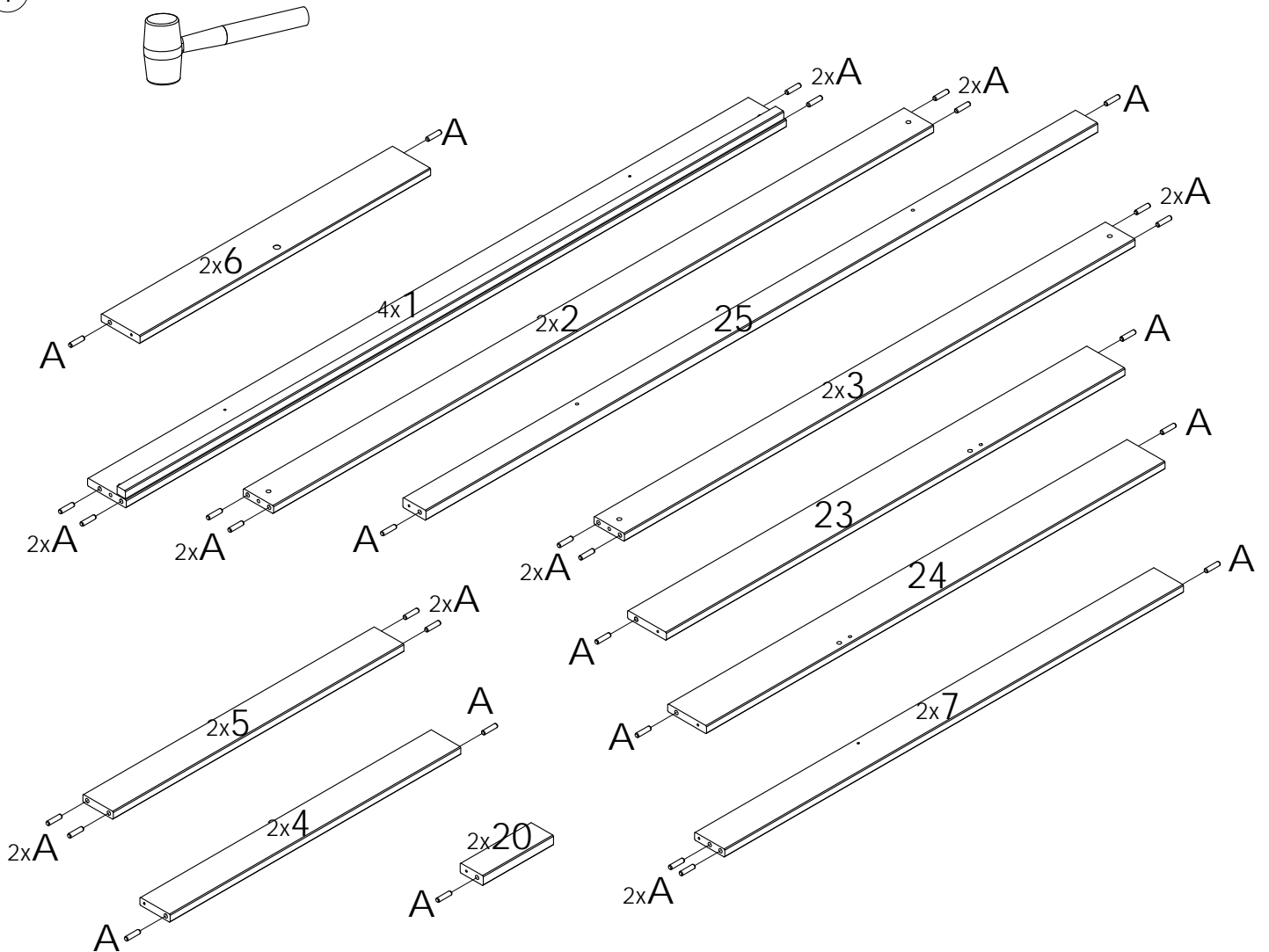

A		10x40	x62
---	---------------------------------------------------------------------------------------	-------	-----

②

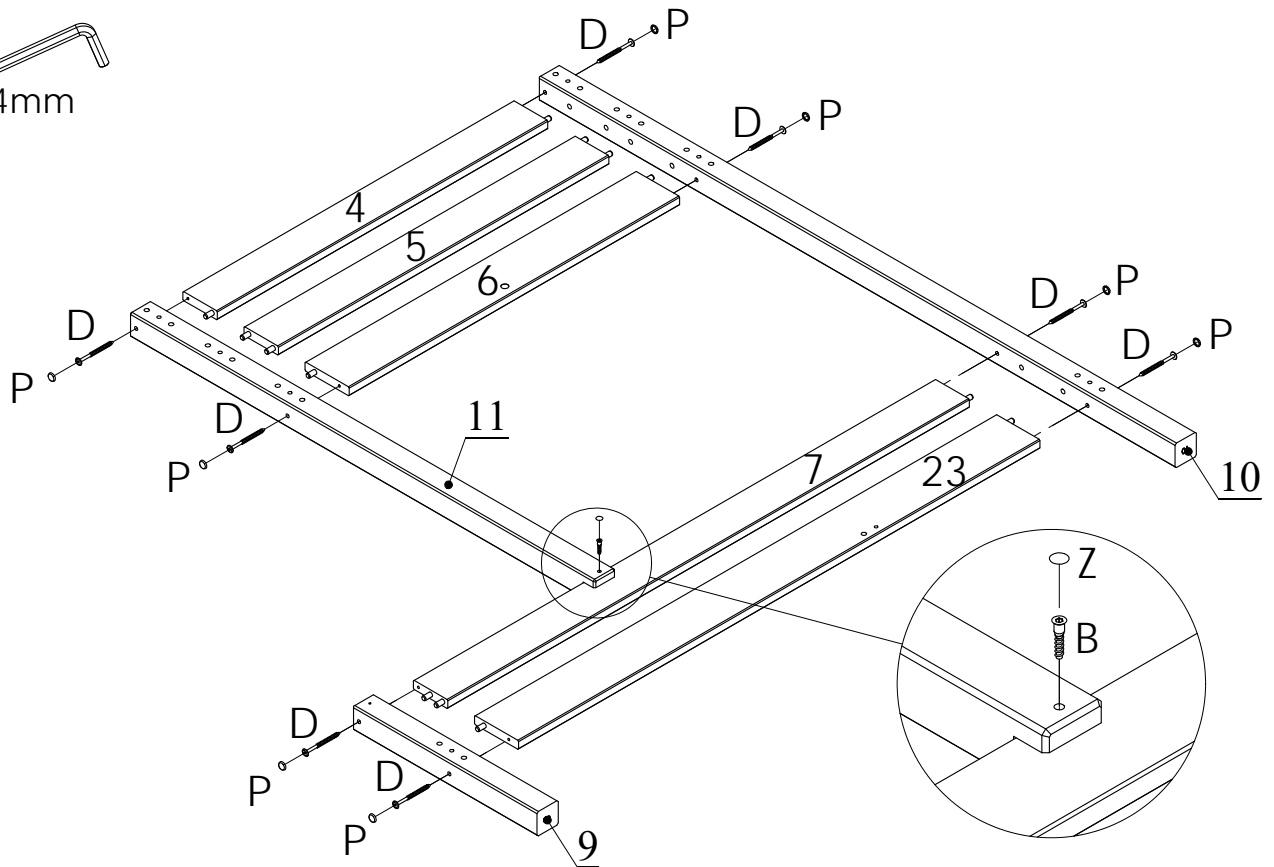
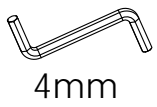

D		6,3x90	x8
P		D15x18	x8

B		7x30	x1
Z		D4x13	x1

③

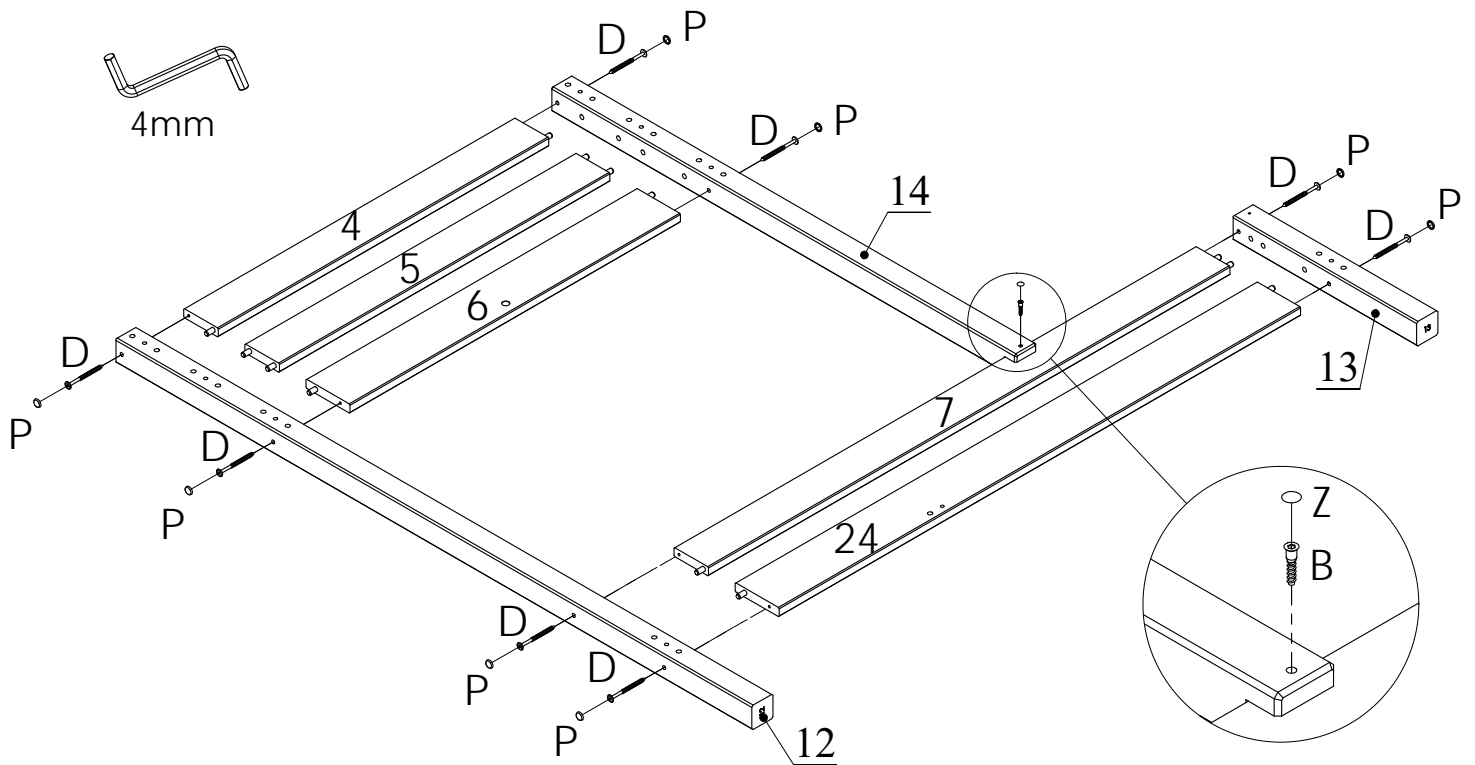
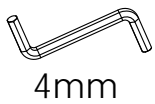



D		6,3x90	x8
P		D15x18	x8

B		7x30	x1
Z		D4x13	x1

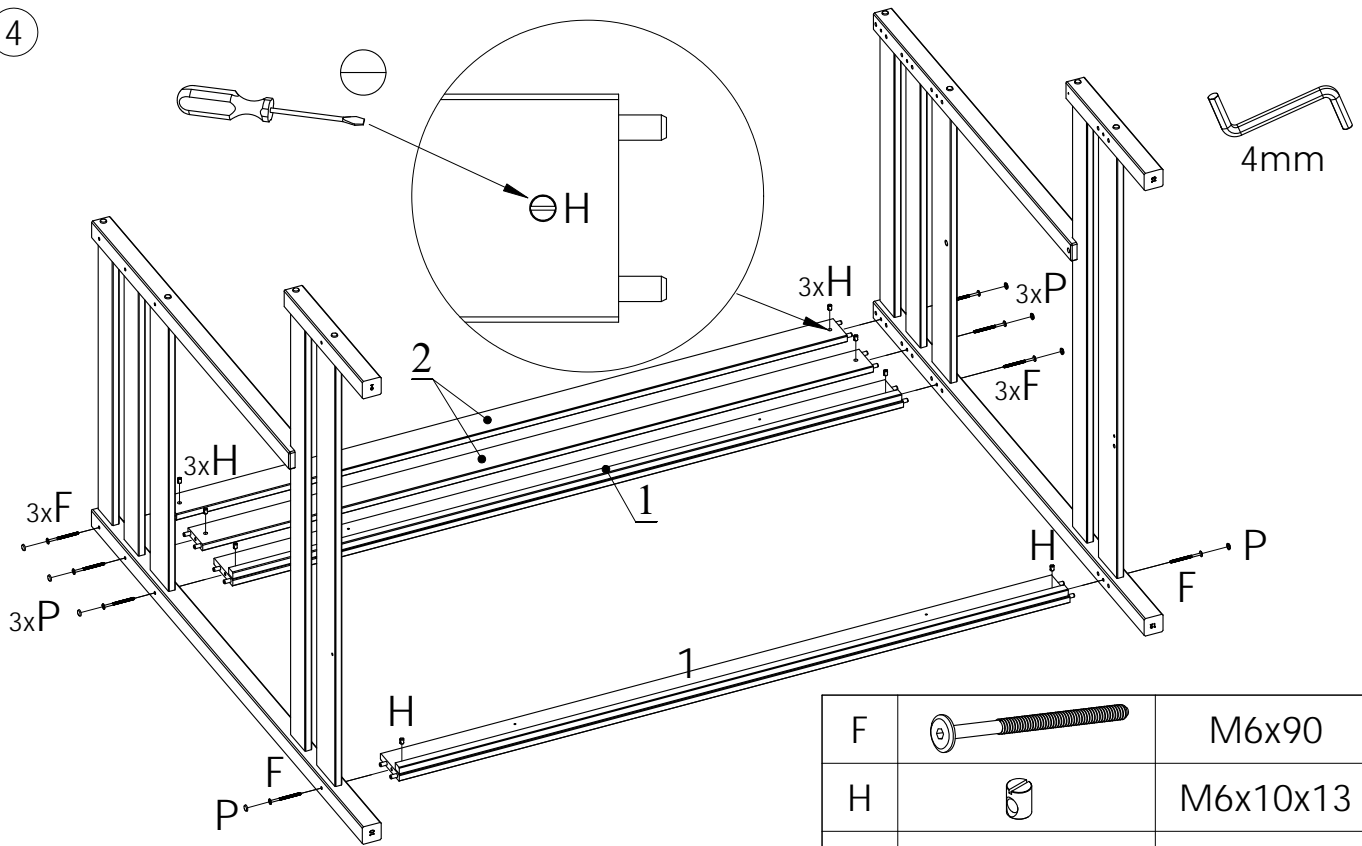

4



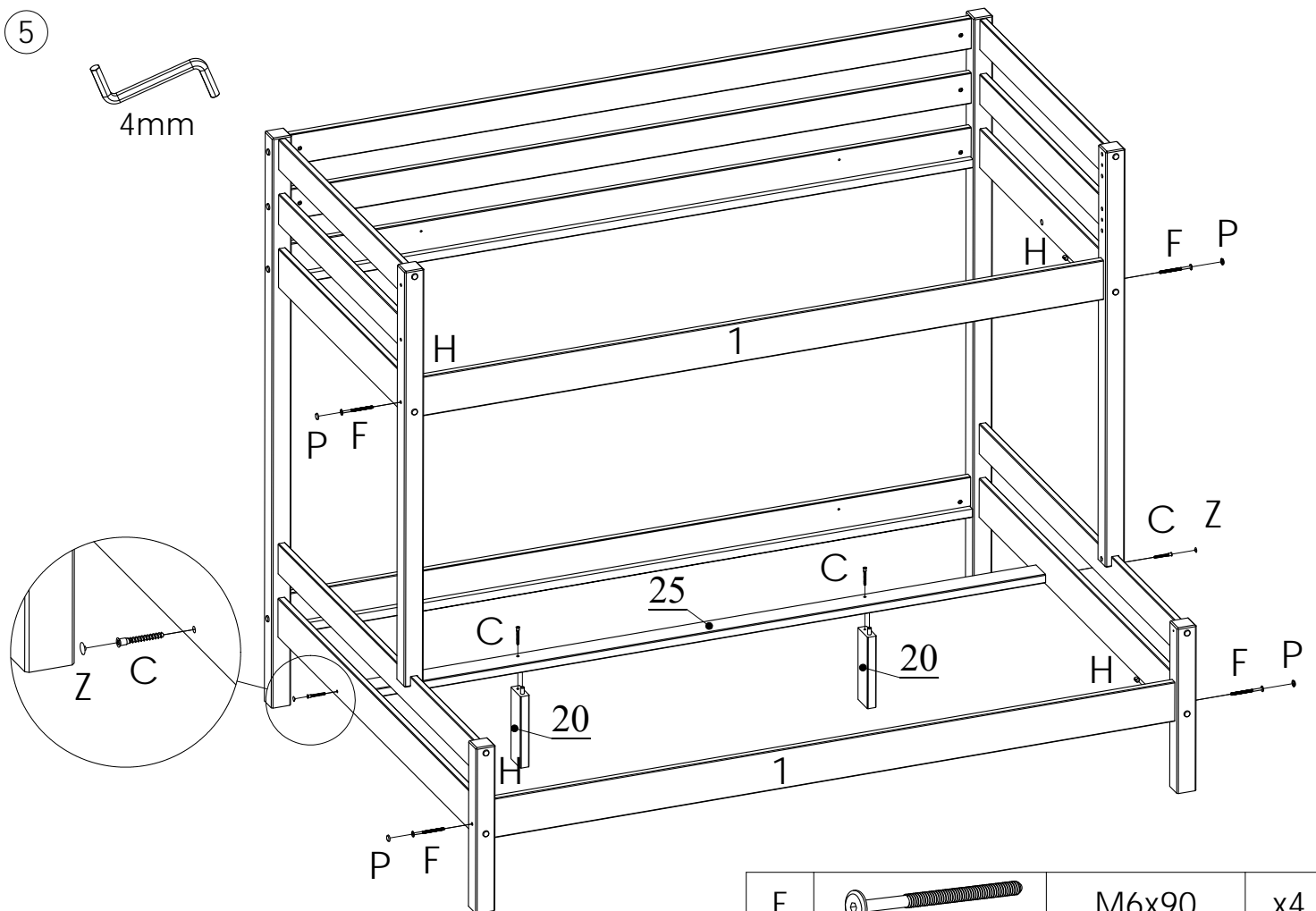

F		M6x90	x8
H		M6x10x13	x8
P		D15x18	x8

5





C		7x50	x4
Z		D4x13	x2

F		M6x90	x4
H		M6x10x13	x4
P		D15x18	x4

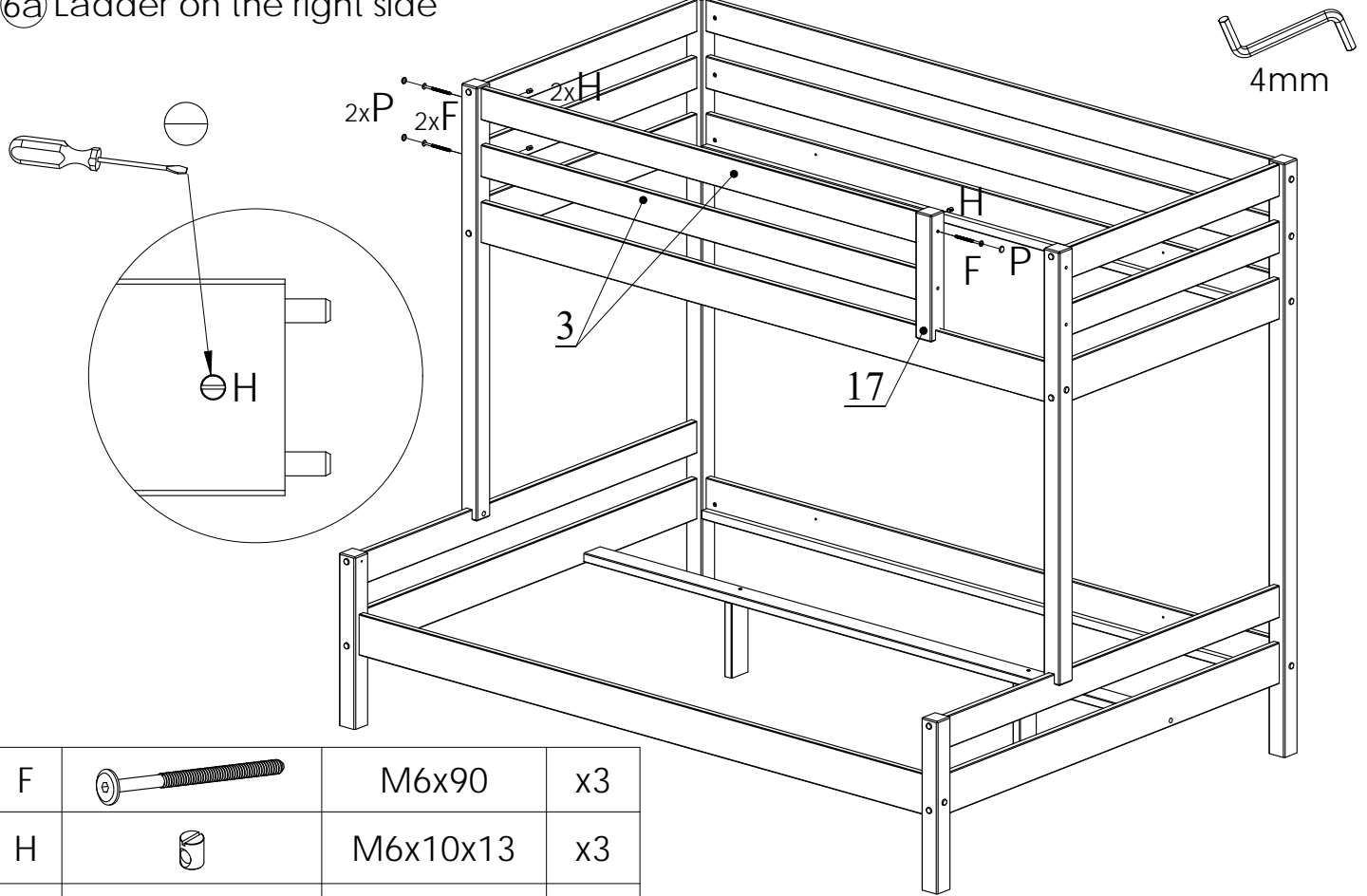

6a Ladder on the right side

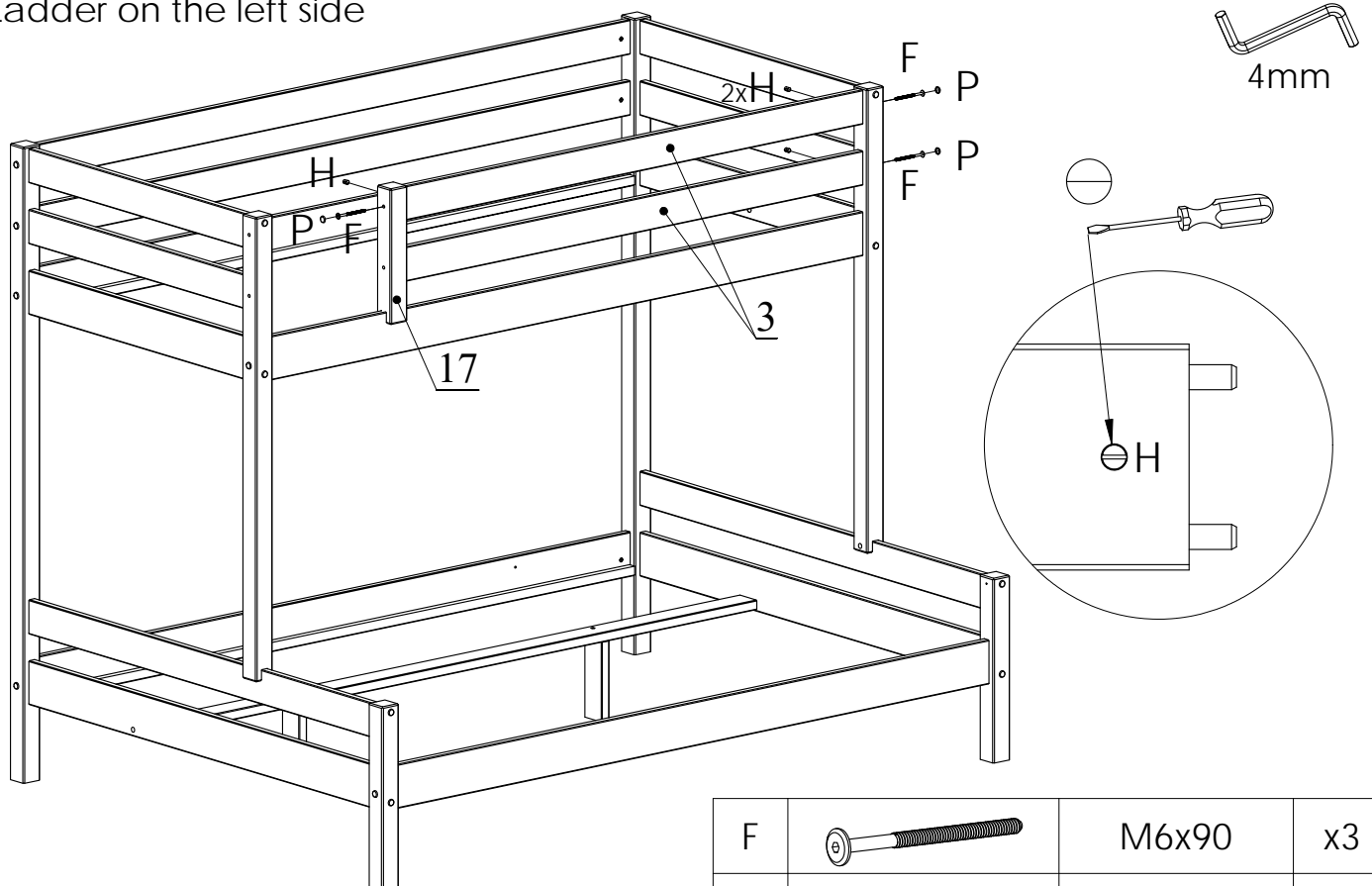

F		M6x90	x3
H		M6x10x13	x3
P		D15x18	x3

6b Ladder on the left side



F		M6x90	x3
H		M6x10x13	x3
P		D15x18	x3

7

Always placed inside the ladder

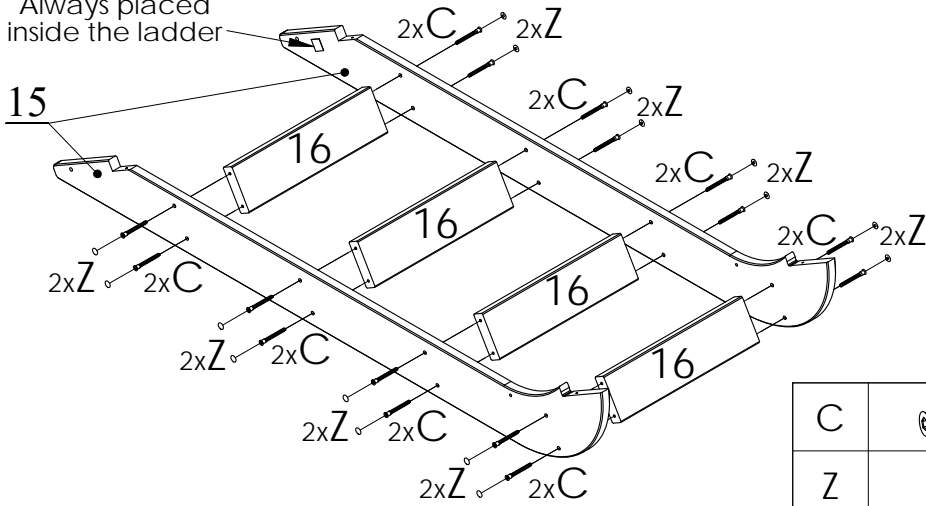

C		7x50	x16
Z		D4x13	x16

8

Max. mattress height

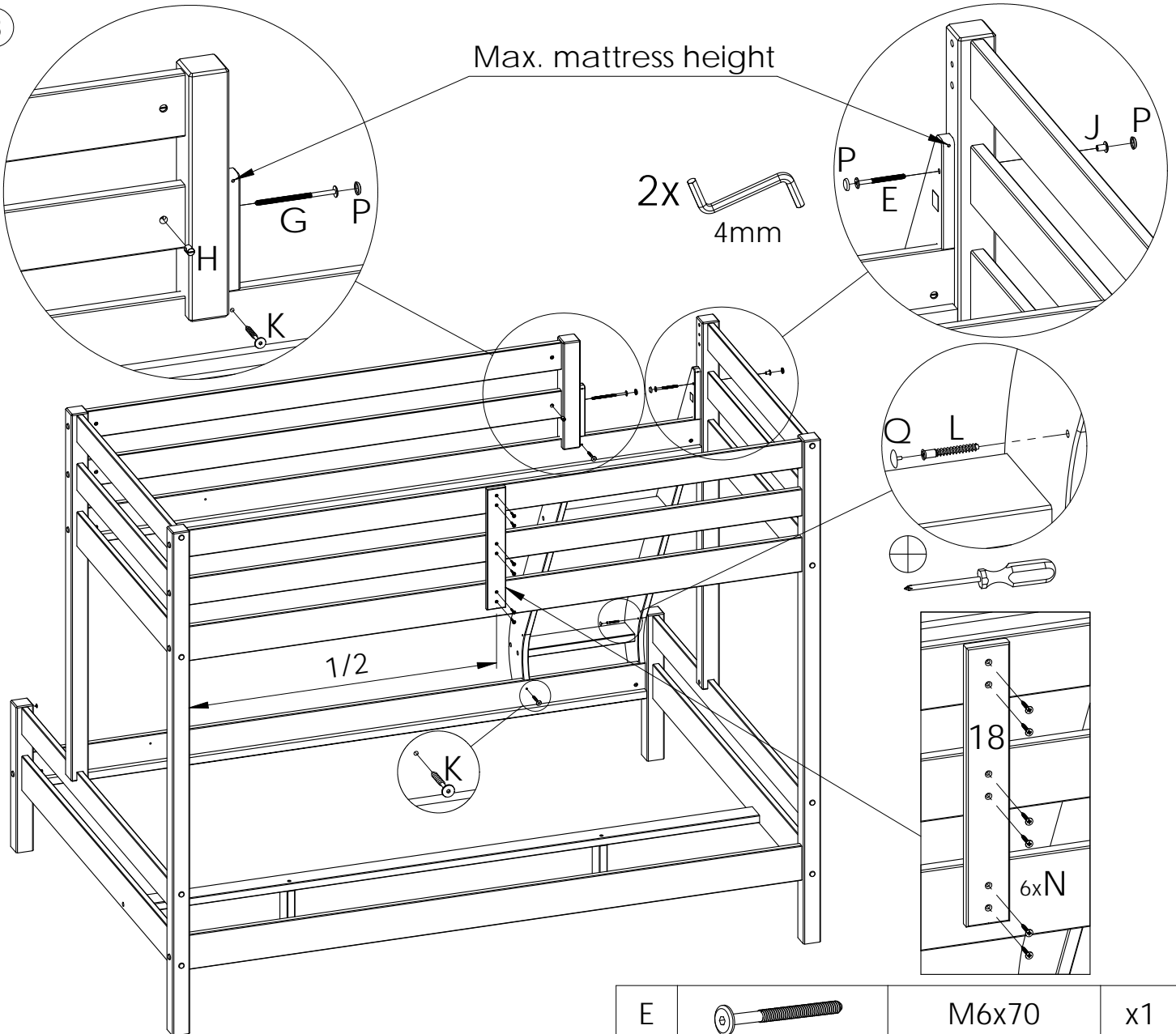



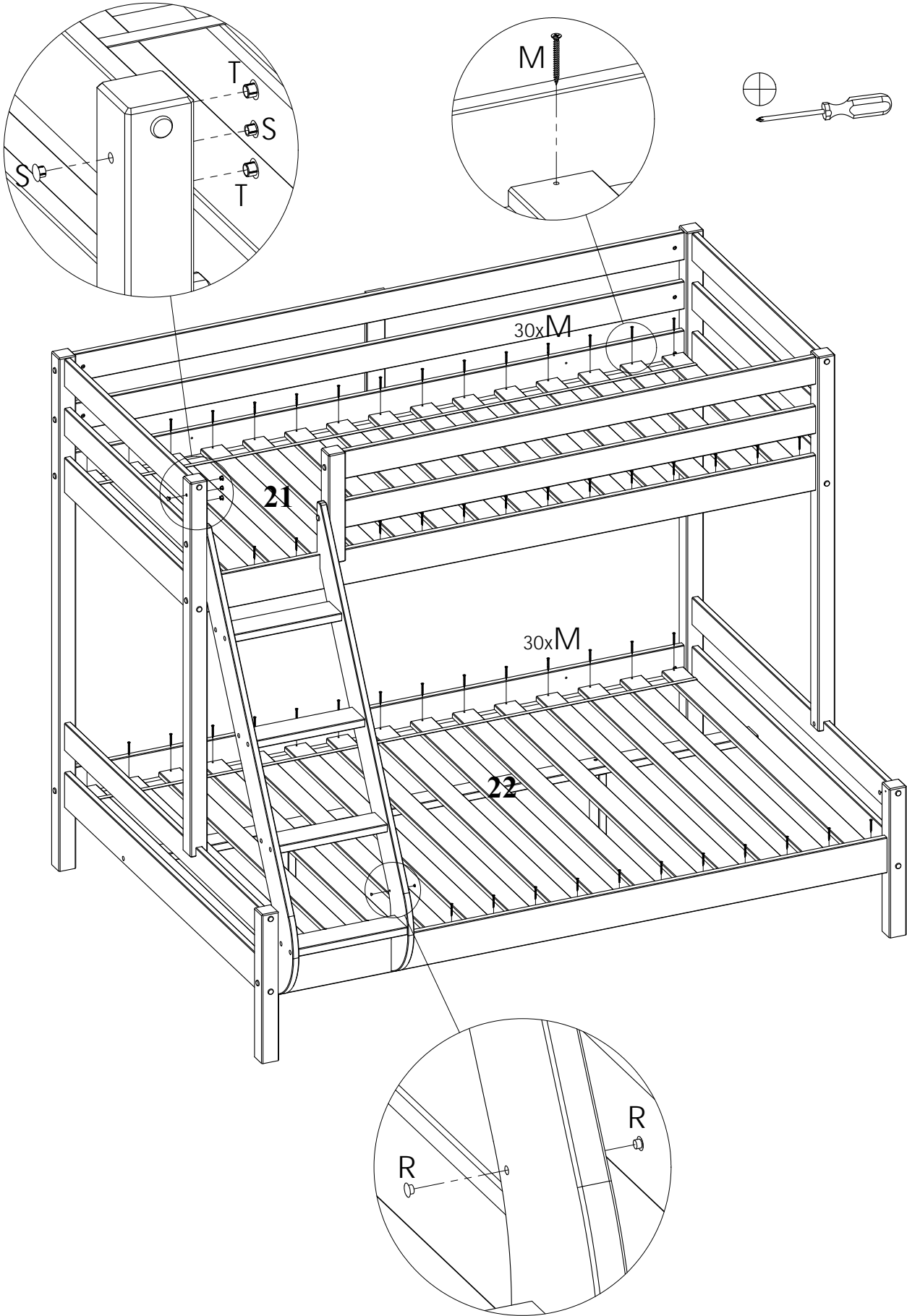

J		M6x8x12x15	x1
K		55/12,5x5	x2
L		5x38	x1
Q		D2,3x12	x1

E		M6x70	x1
G		M6x110	x1
H		M6x10x13	x1
P		D15x18	x4
N		5x30	x6

9



R		D5x8	x2
S		D8x13	x2

M		3,5x40	x60
T		D10x15	x2